



July 8, 2020

Region 10 Education Service Center
Attn: Ms. Sue Hayes, Chief Financial Officer
400 E Spring Valley Road
Richardson, TX 75081

Re: Request for Proposal EQ-052920-01 Furniture and Storage, Related Products and Services

Dear Ms. Hayes:

The Artcobell Corporation is pleased to submit our proposal for the Region 10 Education Service Center RFP EQ-052920-01. Please accept the uploaded files via the Bonfire tool as our formal submittal.

There is not any propriety information contained in the Artcobell submission. Should you have any questions or require additional information, please contact Cindy Hawkins, Bid/Contract Manager | phone 254-899-3610 | chawkins@artcobell.com.

Sincerely,

A handwritten signature in blue ink, appearing to read "Rick Parker".

Rick Parker
President

OPEN RECORDS POLICY ACKNOWLEDGMENT AND ACCEPTANCE

Be advised that all information and documents submitted will be subject to the Public Information Act requirements governed by Chapter 552 of the Texas Government Code.

Because contracts are awarded by a Texas governmental entity, all responses submitted are subject to release as public information after contracts are executed. If a Respondent believes that its response, or parts of its response, may be exempted from disclosure to the public, the Respondent must specify page-by-page and line-by-line the parts of the response, which it believes, are exempted from disclosure. In addition, the Respondent must specify which exception(s) are applicable and provide detailed reasons to substantiate the exception(s). Respondent must provide this information on the "Acknowledgement and Acceptance to Region 10 ESC's Public Information Act Policy" form found on the next page of this solicitation. Any information that is unmarked will be considered public information and released, if requested under the Public Information Act.

The determination of whether information is confidential and not subject to disclosure is the duty of the Office of Attorney General (OAG). Region 10 ESC must provide the OAG with the information requested in order for the OAG to render an opinion. In such circumstances, Respondent will be notified in writing that the material has been requested and delivered to the OAG. Respondent will have an opportunity to make arguments to the OAG in writing regarding the exception(s) to the TPIA that permit the information to be withheld from public disclosure. Respondents are advised that such arguments to the OAG must be specific and well-reasoned—vague and general claims to confidentiality by the Respondent are generally not acceptable to the OAG. Once the OAG opinion is received by Region 10 ESC, Region 10 ESC must comply with the opinions of the OAG. Region 10 ESC assumes no responsibility for asserting legal arguments on behalf of any Respondent. Respondents are advised to consult with their legal counsel concerning disclosure issues resulting from this procurement process and to take precautions to safeguard trade secrets and other proprietary information.

After completion of award, these documents will be available for public inspection.

Signature below certifies complete acceptance of Region 10 ESC's Open Records Policy, except as noted below (additional pages may be attached, if necessary). Check one of the following responses to the Acknowledgment and Acceptance of Region 10 ESC's Open Records Policy below:

We acknowledge Region 10 ESC's Public Information Act policy and declare that no information submitted with this proposal, or any part of our proposal, is exempt from disclosure under the Public Information Act.

(Note: All information believed to be a trade secret or proprietary must be listed below. It is further understood that failure to identify such information, in strict accordance with the instructions below, will result in that information being considered public information and released, if requested under the Public Information Act.)

We declare the following information to be a trade secret or proprietary and exempt from disclosure under the Public Information Act.

(Note: Respondent must specify page-by-page and line-by-line the parts of the response, which it believes, are exempt. In addition, Respondent must specify which exception(s) are applicable and provide detailed reasons to substantiate the exception(s).)

July 8, 2020
Date

Rick Parker, President
Authorized Signature & Title

Appendix A: QUESTIONNAIRE

COMPANY PROFILE

1. What is your company's official registered name?

Response: Artcobell Corporation

2. What is your company's Dun & Bradstreet (D&B) number?

Response: 07-262-2830

3. What is/are your corporate office location(s)?

Response: 1301 Industrial Boulevard Temple, TX 76504

4. Please provide a brief history of your company, including the year it was established.

Response: Artcobell manufactures and distributes high quality, durable furniture for the education market. With a strong focus on safety, Artcobell constructs resilient products that are known for their flexibility of use within different settings. Artcobell has been located in Temple, TX since 1965, where it focuses on consistent product innovation to meet the changing needs of our customers. At Artcobell, our passion is building school furniture that supports teachers and students now and into the future. We are driven by the innovative learning strategies that are changing the face of education, creating durable, high quality products that meet the needs of active, flexible, personalized learning environments. To ensure safety is met, Artcobell maintains the OSHA 300, 300-A and 301 logs required by 29 CFR Part 1904.

Artcobell has grown into a position of leadership in the educational furniture industry. As a leading manufacturer of classroom furniture, Artcobell offers one of the broadest product portfolios in the industry. There has been significant investment into the business for new product development, new selling tools and resources for dealers, and improved operational reliability. Artcobell has a long history of providing quality classroom products and is poised to continue that tradition with a renewed energy for growth.

We listen to teachers and students, administrators and maintenance people. Our products are designed and built based on input from our customers. We closely follow the changes in educational strategies so that we can provide solutions that are flexible, collaborative, personalized and active. Comfort is a hallmark of our seating line, whether it is traditional poly shell seating solutions like Alphabet and Discover, adaptable seating like MOV for students who like to wiggle, configurable options like ARC from our soft seating line. Configurability drives the design of our desks and tables – allowing teachers and students to build classrooms, from floor to standing height, however and wherever they want. Our Makerspace cabinets and tables are designed to foster creativity with ample workspace and plenty of room to store supplies and equipment.

Texas-based; USA made: Because we're nimble and domestic, we can react quickly to your needs. An engaged culture of continuous improvement led by dedicated employees consistently makes furniture tough enough to stand up to the most demanding users. Our focus on local suppliers keeps our carbon footprint lower and gives us a reliable source of raw materials, allowing us to offer the shortest lead times in the industry.

We serve our markets through a network of authorized and trained dealers who will handle everything from small replacement orders to complete turnkey projects. Our national dealer network is dedicated to making your projects a success, from design through the first day of school. A list of authorized dealers has been provided.

The markets Artcobell serves are:

- K-12 Public Schools
- K-12 Private and Charter Schools
- Colleges and Universities
- Science Research and Laboratory Facilities
- Conference Facilities
- Public Assembly Facilities

The Artcobell brand brings years of experience and expertise within the school furniture industry. Customers can have confidence in knowing that Artcobell is able to provide every customer the following:

- Industry's broadest, most effective distribution network
- Strong, well established brand names
- Superior customer service
- Industry's broadest product offering with a superior value proposition
- Entrenched culture of continuous improvement
- Excellent product development infrastructure
- More than 1,000,000 square feet of manufacturing and distribution space
- More than 300 dedicated employees

Artcobell's number one goal is quality. The production of safe, reliable and long-lasting products is not simply a phrase but a way of life. Our in-house quality assurance testing facility ensures the accuracy and consistency of our raw materials and the stability of our finished goods. Scheduled and random testing during our manufacturing process enables us to consistently deliver the very best in classroom furniture. Extensive hours of testing are completed before we even begin our manufacturing process. The concept of testing in simulated, real life situations from repetitive impact and load testing to the sliding of our chairs and combos for wear assessment...simulates the rigorous environment of today's classroom. Stringent quality standards combined with testing and quality checks during manufacturing and assembly guarantee that you will have the very best in classroom furniture and peace of mind. Our dedication and commitment to quality is goal one.

5. Who is your competition in the marketplace?

Response:	Academia	Norva Nivel
	Alumni	Paragon
	Classroom Essentials	Scholarcraft
	FomCore	Smith System
	KI	VS
	Mooreco / Balt Best Rite	Wisconsin Bench

Above is just a few of the competitors.

6. What are your overall annual sales for last three (3) years?

Response: 2017 Revenue: \$34,274,592
2018 Revenue: \$37,055,969
2019 Revenue: \$43,131,490

7. What are your overall public sector sales, excluding Federal Government, for last three (3) years?

Response: 2017 Revenue: \$34,274,592
2018 Revenue: \$37,055,969
2019 Revenue: \$43,131,490

8. What is your strategy to increase market share in the public sector?

Response: Sales Staff Support: Our national dealer network is an integral part of our service and support system. We are a closed-line of furniture and operate thru authorized dealers only. Unlike open-line brands, we select strong, reliable and financially stable dealers in each market, providing schools with assurance that they will get the service they expect on Artcobell products. Each state has an authorized and trained Artcobell dealer. Each dealer is trained on our products and has established long term relationships with Artcobell. Each dealer is financially sound and able to meet the demands of the contract.

Artcobell regularly holds training sessions with dealers, customers and designers. The sessions focus on the evolving education market, Artcobell strategy, and product positioning. Artcobell is qualified to give accredited CEU presentations to IDCEC and AIA members and will continually add courses to benefit our customers.

Selling Tools: Artcobell's industry leading website (www.artcobell.com) provides extensive information on our products, distribution, history, case studies, philanthropy, and design methodology for progressive learning spaces. Our brochures, catalog and animations further help customers visualize and understand how to design progressive spaces using Artcobell products and continuously add new selling resources. Artcobell supports several 3D rendering platforms, including *KITS Collaborator*, *CET Designer* and *Project Matrix* which help us help customers visualize and design spaces real time. We have added a large inventory of images and provide technical specifications for all our products. The Artcobell web site has a dealer portal site that provides content directly to our dealer partners in a streamlined process in real time. The web portal offers product information, marketing resources, order management, communication center and design resources.

Trade Shows: Artcobell participates in several tradeshows every year, including EDspaces, LearningScapes and the National School Board Association annual conferences. We will continue promoting our products in multiple tradeshows directly or through our dealer partners to increase visibility and awareness of our products.

9. What differentiates your company from competitors specifically in the public sector?

Response: Artcobell offers one of the broadest product portfolios in the industry. Artcobell works with a North American distribution network of independent, authorized dealers, with representation in every state of the United States. Each dealer within our network is fully trained on our product line and can get product to destination when needed. In addition to our dealer network, we have two warehouses with more than 1,000,000 square feet of manufacturing and distribution space.

Artcobell has an experienced shipping/distribution team with dedicated partner carrier relationships to ensure safe and timely delivery of all products. We have approximately 540K square feet of dedicated warehouse and distribution space allowing for flexibility in loading and schedule distribution.

Artcobell generates invoices directly after product is shipped. Once product is scanned and verified as shipped, the bill of lading and packing slip confirm when product was shipped, who it shipped with and what specific products were shipped. The invoices are then generated and sent via email or physical mail depending on customer preference.

After delivery of product, the end user can work with the authorized dealer on any product that was received damaged. The authorized dealer will contact the Artcobell customer service team to evaluate what options are available and to ensure the end user's product is replaced in a timely manner.

Standard lead time for having your order ready to ship is 5 to 6 weeks after receipt of order. In an order requires expediting, the customer service team needs to be contacted. The customer service team will coordinate with manufacturing and advise what options are available to support the customer's needs.

10. Please provide your company's environmental policy and/or sustainability initiative.

Response: Artcobell is committed to our community by being environmentally conscious and striving to ensure the continued availability of natural resources for current and future generations. To carry out this commitment, we are committed to reducing waste, creating sustainability, and reducing the use of natural resources and harm to the environment. This applies to our offices as well as the plant processes. As part of this commitment, we monitor the following:

- Airborne VOC related emissions and reporting the results to the EPA as well as the amount of VOC solvents contained in miscellaneous solvents.
- Gallons of water used at each facility.
- Solid waste that is shipped out of each facility and determining what amount is recyclable and what is hazardous.
- Electricity that is used in the facility and what amount comes from renewable sources, the amount of natural gas or propane, the amount of fuel oil and the amount of diesel fuel used at each facility.
- Top commodities used in product (by weight) purchased.
- Raw commodities included in the solid waste stream; produced from recycled/renewable sources and raw commodities that get recycled at the end of their life-cycle.

Artcobell will continue to invest in research and development of durable sustainable new materials that are made of renewable and recyclable resources. Our manufacturing processes also reflect attention to minimizing waste, and recycling by products of production.

The entire Artcobell line of furniture is certified as Indoor Advantage Gold by SCS Global Services (SCS). SCS has been providing global leadership in third-party quality, environmental and sustainability verification, certification, auditing, testing and standards development for three decades. Its programs span a cross-section of industries, recognizing achievements in green building, product manufacturing and more. SCS is accredited to provide services under a wide range of nationally and internationally recognized certification programs.

Indoor Advantage Gold certification is SCS Global Services highest level of indoor air quality performance for furniture. The certification assures that furniture products support a healthy indoor environment by meeting strict chemical emission limits for volatile organic compounds (VOCs). To be certified, products must be tested by independent labs for compliance with the ANSI/BIFMA X7.1, and either ANSI/BIFMA e.3 or CDPH/EHLB Standard Method V1-1 for VOC emissions of concerns.

11. Diversity program - Do you currently have a diversity program or any diversity partners that you do business with?

Response: Yes
 No

a. If the answer is yes, do you plan to offer your program or partnership through Equalis Group?

Yes
 No

(If the answer is yes, attach a statement detailing the structure of your program, along with a list of your diversity alliances and a copy of their certifications.)

b. Will the products accessible through your diversity program or partnership be offered to Equalis Group members at the same pricing offered by your company?

(If answer is no, attach a statement detailing how pricing for participants would be calculated.)

12. Diversity Vendor Certification Participation - It is the policy of some entities participating in Equalis Group to involve minority and women business enterprises (M/WBE), small and/or disadvantaged business enterprises, disabled veterans business enterprises, historically utilized businesses (HUB) and other diversity recognized businesses in the purchase of goods and services. Respondents shall indicate below whether or not they hold certification in any of the classified areas and include proof of such certification with their response.

Response:

a. Minority Women Business Enterprise

Respondent certifies that this firm is an MWBE Yes No

List certifying agency: _____

b. Small Business Enterprise (SBE) or Disadvantaged Business Enterprise (DBE)

Respondent certifies that this firm is a SBE or DBE Yes No

List certifying agency: _____

c. Disabled Veterans Business Enterprise (DVBE)

Respondent certifies that this firm is an DVBE Yes No

List certifying agency: _____

d. Historically Underutilized Businesses (HUB)

Respondent certifies that this firm is an HUB Yes No

List certifying agency: _____

e. Historically Underutilized Business Zone Enterprise (HUBZone)

Respondent certifies that this firm is an HUBZone Yes No

List certifying agency: _____

f. Other

Respondent certifies that this firm is a recognized diversity certificate holder Yes No

List certifying agency: _____

PRODUCTS/PRICING OFFERED:

13. Please summarize the products and services you are offering.
Response: Artcobell is proposing our complete catalog offering.

14. What makes your offering unique from other similar competitors?
Response: Artcobell furniture is made in the U.S.A. Our manufacturing facility in Temple, Texas uses “lean” manufacturing principals to produce and assemble every piece of furniture we offer. From metal bending to chrome-plating and powder-coating, to panel production, laminating, cutting and edge-banding, our American workforce builds high-quality, durable furniture that meets the teaching and learning needs of today’s educational environments.

Because we're nimble and domestic, we can react quickly to your needs. An engaged culture of continuous improvement led by dedicated employees consistently makes furniture tough enough to stand up to the most demanding users. Our national dealer network is dedicated to making your projects a success, from design through the first day of school. We are flexible and responsive: uniquely organized to provide personalized solutions and respond to your needs quickly and creatively. We are consistently reliable: delivering what you need when you need it. We are problem solvers: providing the tools to help schools navigate the demands of today's learning strategies.

At Artcobell, our passion is building school furniture that supports teachers and students now and into the future. We are driven, by the innovative learning strategies that are changing the face of education, to create great looking, durable, high quality products that meet the needs of active, flexible, personalized learning environments.

Ethical responsibility is our promise at Artcobell. We insist on using local suppliers and partners, efficient shipping methods & clean manufacturing processes to make long lasting products and reach our global customers. We are an organization that shares its growth and profits with its community.

15. Were all products/lines/services and pricing being made available under this contract provided in the attachment B and/or Appendix B, pricing sections?
Response: Yes
16. Does the respondent agree to offer all future product introductions at prices that are proportionate to contract pricing offered herein?
Response: Yes
 No
(If answer is no, attach a statement detailing how pricing for participants would be calculated.)
17. Define your standard terms of payment
Response: Net 30 days from the invoice date.

PERFORMANCE CAPABILITIES:

18. States Covered - Respondent must indicate any and all states where products and services are being offered.

Response: 50 States & District of Columbia (Selecting this box is equal to checking all boxes below)

- 50 States & District of Columbia (Selecting this box is equal to checking all boxes below)
- Alabama
- Alaska
- Arizona
- Arkansas
- California
- Colorado
- Connecticut
- Delaware
- District of Columbia
- Florida
- Georgia
- Hawaii
- Idaho
- Illinois
- Indiana
- Iowa
- Kansas
- Kentucky
- Louisiana
- Maine
- Maryland
- Massachusetts
- Michigan
- Minnesota
- Mississippi
- Missouri
- Montana
- Nebraska
- Nevada
- New Hampshire
- New Jersey
- New Mexico
- New York
- North Carolina
- North Dakota
- Ohio
- Oklahoma
- Oregon
- Pennsylvania
- Rhode Island
- South Carolina
- South Dakota
- Tennessee
- Texas
- Utah
- Vermont
- Virginia
- Washington
- West Virginia
- Wisconsin
- Wyoming

- All U.S. Territories & Outlying Areas (Selecting this box is equal to checking all boxes below)
- American Samoa
- Federated States of Micronesia
- Guam
- Midway Islands
- Northern Marina Islands
- Puerto Rico
- U.S. Virgin Islands

19. List the number and location of offices, or service centers for all states being proposed in solicitation.

Response: One location – Temple, Texas.

20. Distribution Channel: Which best describes your company’s position in the distribution channel:

Response: Manufacturer marketing through reseller (authorized dealers)

- Manufacturer direct
- Authorized distributor
- Value-added reseller
- Certified education/government reseller
- Manufacturer marketing through reseller
- Other

21. Provide relevant information regarding your ordering process including your ability for purchasing group members to verify they are receiving contract pricing.
Response: Customers will be able to verify they are receiving the correct contract price by utilizing a contract sales sheet with the discount structure matrix that can be obtained from the vendor or the authorized dealer.

22. Describe your company's Customer Service Department (hours of operation, number of service centers, etc.).
Response: Artcobell's dedicated customer service team can take live calls from 8am to 5pm CST at 1-877-778-1811 and would be able to respond to emergency orders on inquiries. If there is an emergency order, the customer service team would gather the appropriate information from the customer and work to determine the best possible outcome for the customer.

Artcobell offers its authorized dealers on-line order tracking where they can log into the website to view all purchase orders currently in the system and have access to the date of expected order completion. This service is available 24 hours a day and is accessible from any computer with the use of a password-protected entry.

Our customer service team prides itself on same-day order entry. Through years of experience, we understand the importance of on-time delivery to ensure that the classrooms are furnished before the school years begins. Artcobell can report out on a monthly basis. When purchase orders related to the contract are received, the Artcobell customer service team will enter the purchase order with contract details into our ERP system. The order entry process will allow us to pull sales details and report timely and accurately.

23. Provide your safety record, safety rating, EMR and worker's compensation rate where available
Response:
Worker's Compensation: Artcobell has had 14 recordable accidents this year, but none of them serious.
EMR Rate: 111%

24. Describe the capacity of your company to report monthly sales through this agreement.
Response: Artcobell can report out on a monthly basis. When purchase orders related to the contract are received, the Artcobell customer service team will enter the purchase order with contract details into our ERP system. The order entry process will allow us to pull sales details and report timely and accurately

25. Describe the capacity of your company to provide management reports, i.e. consolidated billing by location, time and attendance reports, etc. for each eligible agency.
Response: The order entry process will allow us to pull sales details as needed.

QUALIFICATION AND EXPERIENCE:

Response: Artcobell manufactures and distributes high quality, durable furniture for the education market. With a strong focus on safety, Artcobell constructs resilient products that are known for their flexibility of use within different settings. Artcobell has been located in Temple, TX since 1965, where it focuses on consistent product innovation to meet the changing needs of our customer. At Artcobell, our passion is building school furniture that supports teachers and students now and into the future. We are driven by the innovative learning strategies that are changing the face of education, creating durable, high quality products that meet the needs of active, flexible, personalized learning environments. The manufacturing facility is located at 1302 Industrial Boulevard, Temple, TX.

Artcobell has grown into a position of leadership in the educational furniture industry. As a leading manufacturer of classroom furniture, Artcobell offers one of the broadest product portfolios in the industry. There has been significant investment into the business for new product development, new selling tools and resources for dealers, and improved operational reliability. Artcobell has a long history of providing quality classroom products and is poised to continue that tradition with a renewed energy for growth.

We listen to teachers and students, administrators and maintenance people. Our products are designed and built based on input from our customers. We closely follow the changes in educational strategies so that we can provide solutions that are flexible, collaborative, personalized and active. Comfort is a hallmark of our seating line, whether it is traditional poly shell seating solutions like Alphabet and Discover, adaptable seating like MOV for students who like to wiggle, configurable options like ARC from our new soft seating line. Configurability drives the design of our desks and tables – allowing teachers and students to build classrooms, from floor to standing height, however and wherever they want. Our Makerspace cabinets and tables are designed to foster creativity with ample workspace and plenty of room to store supplies and equipment.

Texas-based; USA made: Because we're nimble and domestic, we can react quickly to your needs. An engaged culture of continuous improvement led by dedicated employees consistently makes furniture tough enough to stand up to the most demanding users. Our focus on local suppliers keeps our carbon footprint lower and gives us a reliable source of raw materials, allowing us to offer the shortest lead times in the industry.

The Artcobell admin team has over 150 years of combined experience in the K-12 furniture market. No manufacturer is better experienced to provide the best in quality, service and warranty.

Artcobell has no past litigations, bankruptcy, reorganization, state investigations of entity or current officers and directors.

26. Please provide contact information and resumes for the person(s) who will be responsible for the following areas.

Executive Contact

Contact Person: Rick Parker

Title: President

Company: Artcobell Corporation

Address: 1302 Industrial Blvd

City: Temple State: TX Zip: 76504

Phone: 877-778-1811 Fax: _____

Email: rparker@artcobell.com

Account Manager / Sales Lead

Contact Person: Stephen Sykes

Title: Vice President, Sales

Company: Artcobell Corporation

Address: 1302 Industrial Blvd

City: Temple State: TX Zip: 76504

Phone: 254-721-5873 Fax: _____

Email: ssykes@artcobell.com

Contract Management (if different than the Sales Lead)

Contact Person: Cindy Hawkins

Title: Bid/Contract Manager

Company: Artcobell Corporation

Address: 1302 Industrial Blvd

City: Temple State: TX Zip: 76504

Phone: 254-899-3610 Fax: _____

Email: chawkins@artcobell.com

Billing & Reporting/Accounts Payable

Contact Person: Cindy Hawkins

Title: Bid/Contract Manager

Company: Artcobell Corporation

Address: 1302 Industrial Blvd

City: Temple State: TX Zip: 76504

Phone: 254-899-3610 Fax: _____

Email: chawkins@artcobell.com

Marketing

Contact Person: Alison DeMartino

Title: Director of Marketing

Company: Artcobell Corporation

Address: 1302 Industrial Blvd

City: Temple State: TX Zip: 76504

Phone: 254-899-3625 Fax: _____

Email: ademartino@artcobell.com

27. Provide a minimum of three (3) customer references for product and/or services of similar scope dating within the past 3 years. Please try to provide an equal number of references for K12, Higher Education and City/County entities. Provide the following information for each reference:

Entity Name
Contact Name and Title
City and State
Phone Number
Years Serviced
Description of Services Annual
Volume

Response:

Arlington Public Schools | Arlington, VA
Matt Williams, PE, CCM – Project Manager
Phone: 202-770-6220
Matthew.williams@apsva.us
Provided classroom furniture.
2019 Sales: \$700K
Dealer has been servicing this account with Artcobell furniture for 2 year.

Cypress-Fairbanks ISD | Houston, TX 77269
Severin Castro, Purchasing
Phone: 281-897-4576
Severin.castro@cfisd.net
Provided classroom furniture.
2019 Sales: \$900K
Dealer has been servicing this account with Artcobell for 6 years.

DeKalb County Board of Education | Tucker, GA 30084
Sam Moss Service Center
Belinda Quillet, CPPB
Phone: 404.368.2063
Belinda.quillet@dekalbschoolsqa.org
Provided classroom furniture.
2019 Sales: \$394K
Dealer has been servicing this account with Artcobell furniture for over 8 years.

Jefferson County Public Schools | Louisville, KY 40209
Jeanette Davis
Phone: 502-485-3694
Jeanette.davis@jefferson.kyschool.us
Provided classroom furniture.
2019 Sales: \$143K
Dealer has been servicing this account with Artcobell for over 20 years.

Katy ISD | Katy, TX 77494
Kim Smith, Buyer
Phone: 281-396-7585
kimberlygsmith@katyisd.org
Provided classroom furniture.
2019 Sales: \$1.2M
Dealer has been servicing this account with Artcobell for over 19 years.

Kyrene School District | Tempe, AZ 85284
Jani Fasulo, Assistant Director of Business Services
Phone: 480-541-1371
jfasulo@kyrene.org
Provided classroom furniture.
2019 Sales: \$145K
Dealer has been servicing this account with Artcobell for over 6 years.

Liberty School District | Liberty, MO 64068
Jason Breit, Director of Purchasing
Phone: 816-736-5358
Jason.breit@lps53.org
Provided classroom furniture.
2019 Sales: \$195K
Dealer has been servicing this account with Artcobell for over 7 years.

Owasso Public Schools | Owasso, OK 74055
Jessie Patrick, Director of Construction
Phone: 918-928-4008
Jessie.patrick@owassops.org
Provided classroom furniture.
2019 Sales: \$247K
Dealer has been servicing this account for 1 year.

28. List all cooperative and/or government group purchasing organizations of which your company is currently a member below.

Cooperative/GPO Name	Contract Number	Expiration Date
<u>KCDA Purchasing Cooperative</u>	<u>Bid #20-136</u>	<u>October 31, 2020</u>
<u>County of Fairfax Virginia</u>	<u>4400006227</u>	<u>August 31, 2020</u>
<u>New York Contract - Furniture, All Types</u>	<u>23109</u>	<u>December 1, 2023</u>

29. Describe your company's implementation and success with existing cooperative purchasing programs, if any, and provide the cooperative's name(s), contact person(s) and contact information as reference(s).

Response:

KCDA Purchasing Cooperative Contract
 Yearly Award – Artcobell has held this contract since 2013.
 Kathy Elliott
 Contract & Procurement Specialist
 Email: kelliott@kcda.org
 Phone: (425) 251-8115 Ext 149

County of Fairfax Virginia Contract
 Michael J. Blair, CPCM
 Contract Specialist Supervisor
 Email: Michael.blair@fairfaxcounty.gov
 Phone: 703-324-3215

New York State Contract
 Matthew Jones
 Contract Management Specialist I
 Email: matthew.jones@ogs.ny.gov
 Phone: 518-474-4163

30. Provide a copy of all current licenses, registrations and certifications issued by federal, state and local agencies, and any other licenses, registrations or certifications from any other governmental entity with jurisdiction, allowing Respondent to perform the covered services including, but not limited to licenses, registrations or certifications. M/WBE, HUB, DVBE, small and disadvantaged business certifications and other diverse business certifications, as well as manufacturer certifications for sales and service must be included if applicable.

Response: SCS Global certificates have been provided. Artcobell does not have any diverse business certifications.

31. If your company is offering installation services as part of your response to this RFP, provide your company's policies for background checks and fingerprinting for any employees who may enter customer grounds, or for fulfilling those requirements should a customer require it.
Response: Artcobell operates thru a network of authorized dealers who work with reputable installation teams. Customers can request the appropriate documents needed from the dealers they are working with.

32. Provide information regarding whether your firm, either presently or in the past, has been involved in any litigation, bankruptcy, or reorganization.
Response: Artcobell has no past litigations, bankruptcy, reorganization, state investigations of entity or current officers and directors.

33. Felony Conviction Notice – Please check applicable box:

Response:

- A publicly held corporation; therefore, this reporting requirement is not applicable
- Is not owned or operated by anyone who has been convicted of a felony.
- Is owned or operated by the following individual(s) who has/have been convicted of a felony.

*If the 3rd box is checked a detailed explanation of the names and convictions must be attached.

VALUE ADD:

34. Detail how your organization plans to market this contract within the first 90 days of the award date.

Response:

The 90-Day Strategic Marketing Plan

30 Days:

- Within the first ten days, the executive team of Artcobell will send out an announcement to all key internal sales and marketing personnel and the regional Artcobell dealer network advising of the contract award.
- During this same period of time, we will begin scheduling conference calls and/or webinars with both our internal staff as well as our dealer network to review the terms and conditions of the contract award.
- We will post the award and details of the contract on our dealer portal as well as the web site.
- Artcobell agrees to provide its corporate logos to Region 10 and allow Region 10 to use it in their marketing and communications. Artcobell will include the Region 10 logo in sales materials related to this agreement.
- In addition, we will begin a coordinated call schedule with our authorized dealer to promote the contract agreement.

60 Days:

- With the support of the sales staff, we will continue targeting the counties with the highest potential for one-on-one training with our designated dealer and their personnel.
- We will attend and participate in Region 10 conferences, or supplier specific tradeshows as requested.
- We will introduce and promote the Region 10 agreement to any existing state contracts that Artcobell currently holds. This will be done on an on-going basis.

90 Days:

- We will continue scheduling joint calls with Region 10 officials, our dealers, and the Artcobell sales staff to individual, large potential school districts across the region.
- We will continue to target the list of regional areas with the highest potential to try and secure short-term business for the upcoming year buying cycle.
- We will evaluate our progress and add any region/county to our list to target as we uncover new interest and opportunities.

Value add literature included with our package includes the following presentations/documents:

- Artcobell Top 10 Why Artcobell Presentation
- Artcobell Trends in Education Design Presentation
- Artcobell Adaptable Solutions Presentation
- Artcobell 2020 Catalog

Learning spaces are undergoing a profound and exciting change in design and layout with the advent of the “digital age”. Schools in the US have been designing and creating learning spaces for an industrial age for the last 150 years, and most now need assistance in adapting to this changing paradigm.

Artcobell has been designing and manufacturing quality furniture exclusively for school environments for more than 60 years. We offer a comprehensive depth and breadth of line, including seating, desk, tables, teacher solutions and storage, as well as contemporary solutions for specialty situations such as learning commons, maker spaces, media centers and more. The attached presentations illustrate how Artcobell is uniquely positioned to meet the needs of evolving learning space design.

In conclusion, we would like to assure you that Artcobell provides the broadest product offering at competitive prices with industry leading thought leadership that separates us from other manufacturers in this industry. The current Artcobell price list, Pricer 6.22.20 . v3, is included.

35. Acknowledge that your organization agrees to provide its company logo(s) to Region 10 ESC and agrees to provide permission for reproduction of such logo in marketing communications and promotions.
Response: Artcobell will provide the company logo once a contract is awarded and upon request.
36. Provide the agency spend that your organization anticipates each year for the first three (3) years of this agreement.
Response:
\$ 300K in year one
\$ 500K in year two
\$ 750K in year three
37. Please provide any suggested improvements and alternatives for doing business with your company that will make this arrangement more cost effective for your company and Participating Public Agencies.
Response: Artcobell has no suggested improvements at this time.

ARTCO-BELL CORPORATION

1302 INDUSTRIAL BLVD, TEMPLE, TX 76504
Phone: (254) 778-1811

Experian BIN # 784543641
DUNS # 072622830

Search Inquiry: Artco-Bell Corp / 1302 Industrial Blvd / Temple / TX / 76504

Ordered: 7/6/2020 8:30:13 PM (UTC)

Analytics

Credit Logic Score



Key Score Factors

- TAX LIENS OR JUDGMENTS PRESENT.

Data Depth Score



Data Depth Score is based on:

- Years in business
- Number of trade lines
- Number of bureaus pulled

* Indicates the volume of predictive data available on a company. Scale of 0-9 where 9 indicates greatest level of predictive data.

Business Failure Assessment

Average

Assessment is based on a combination of the Credit Logic Score and Data Depth Score.

MultiMax Credit Guideline

\$71,000

Requested Credit _____

This calculation is based on high credit amounts in recent trade payment history. Your final decision must be based upon your company's own business policies.

Dun & Bradstreet PAYDEX® Score

A unique, dollar weighted indicator of payment performance based on payment experiences, as reported to D&B by trade references. D&B must have three or more pieces of trade to calculate a PAYDEX Score.

D&B PAYDEX:
70

PAYDEX	Payment Practices
100	Anticipate
90	Discount
80	Prompt
70	15 Days Beyond Terms
60	22 Days Beyond Terms
50	30 Days Beyond Terms
40	60 Days Beyond Terms
30	90 Days Beyond Terms
20	120 Days Beyond Terms
1-19	Over 120 Days Beyond Terms
UN	Unavailable

Rating Trend

D&B Standard Rating:

-- (The information available to D&B does not permit us to classify the company within our rating key and that further enquiry should be made before reaching a decision. Some reasons for this include: deficit net worth; bankruptcy proceedings; lack of insufficient payment information; or incomplete history information.)

History Rating:

9079 ("Incomplete")

Financial Condition:

N/A

Derogatory Item Summary

Bankruptcy	No	Judgments	0	Liens	1
Collections	0	Charge-Offs	0	NSF Checks	0
Most recent derogatory	N/A			Derogatory items in previous 24 months	N/A

Fraud Flags

Address Info for: ARTCO-BELL CORPORATION, 1302 INDUSTRIAL BLVD, TEMPLE, TX 76504

- Address zone: Commercial
- Corporate registration information available

Diversity

Minority Owned:	No	Minority Business Enterprise:	No
Female Owned:	No	Female Owned Business Enterprise:	No
Small Business:	No	Certified Small Business:	No
Disadvantaged Business Enterprise:	No	Small/Disadvantaged Business:	No
Veteran Owned:	No	Vietnam Veteran Owned:	No
Disabled Owned:	No	Disabled Veteran Business Enterprise:	No
Service Disabled Veteran Owned:	No	Disadvantaged Veteran Enterprise:	No
HUB Zone Certified Business:	No	Labor Surplus Area Business:	No
8(a) Certified Business:	No	Minority College:	No
Alaskan Native Corporation:	No	Airport Concession Disadvantaged Business Enterprise:	No

Secretary of State or Corporate Registration

The following information was provided by the state of TEXAS

State of Origin:	TX	Charter Number:	0057687300
Date of Incorporation:	9/4/1981	Federal Tax ID:	74-2236641
Current Status:	Active	Agent:	CORPORATION SERVICE COMPANY
Business Type:	Unknown - Profit	Agent Address:	211 E 7TH STREET SUITE 620 AUSTIN TX

Firmographics (data sources: Experian¹, D&B⁴)

Company Type	Whol furniture	National/Tax ID	74-2236641
# Employees	270	SIC	- 4647
Annual Sales	\$43,323,920		Furniture-wholesale - 5021
Years in Business	58		
Date of Incorporation	9/4/1981		
State of Incorporation	TX		

Management & Supplemental Data (data source: Dun & Bradstreet⁴)

Management

CEO:	Rick Parker, President
Current or Former Principals:	KEVIN SMITH KARI MARTIN

Supplemental Data

Other trade names (DBA/AKA):	Artcobell
Line of business:	Whol furniture
Subsidiary Status:	Not a subsidiary
National/Tax Id:	74-2236641
Import/Export status:	Imports and Exports

Corporate Linkage

Linkage occurs when one business has financial and legal responsibility for another. Common linkage identifiers are used to identify these relationships. Corporate Linkage enables businesses to make better decisions through the identification of relationships within a corporate family.

Ultimate Parent — Top-most responsible member of the family tree.

Immediate Parent — Parent refers to a business with a subsidiary. The Immediate Parent is the parent company for the business that is the subject of the profile.

Type of Location	Business Name	Address	Experian BIN
ULTIMATE PARENT	GMA & Associates	602 Cliff Dr Belton, TX 76513	815075602
PARENT/HEADQUARTERS	COUNTERPOINT CAPITAL PARTNERS, LLC	555 W 5TH ST FL 35 LOS ANGELES CA Country: USA	937426186 *Matches inquired upon business

Dun & Bradstreet Payment Habits By Industry

ARTCO-BELL CORPORATION

TEMPLE, TX

D-U-N-S NUMBER: 07-262-2830

There are 52 payment experiences in D&B's file for the most recent 12 months with 43 experiences reported during the last three month period.

Industry	Total # Received	Dollar Amount	Highest Credit	% of Dollar Amount				
				Within Terms	SLOW 1-30	SLOW 31-60	SLOW 61-90	SLOW 91+
Total in D&B's File	52	741,850	200,000					
MISC BUSINESS SERVICE	7	19,000	1,000	54	46	0	0	0
TRUCKING NON-LOCAL	6	138,750	95,000	66	34	0	0	0
TELEPHONE COMMUNICTNS	5	3,500	1,000	100	0	0	0	0
NONCLASSIFIED	4	2,750	1,000	64	36	0	0	0
HELP SUPPLY SERVICE	3	61,000	50,000	100	0	0	0	0
WHOL INDUSTRIAL SUPPL	3	27,500	20,000	82	18	0	0	0
MFG PLASTICS/RESINS	2	20,000	20,000	0	100	0	0	0
WHOL CHEMICALS	2	11,000	10,000	55	45	0	0	0
ARRANGE CARGO TRANSP	2	15,000	7,500	75	25	0	0	0
WHOL ELECTRONIC PARTS	2	750	500	83	17	0	0	0
MFG NONWD OFFICE FURN	1	200,000	200,000	50	50	0	0	0
MFG WOOD FIXTURES	1	100,000	100,000	50	50	0	0	0
WHOL LUMBER/MILLWORK	1	60,000	60,000	50	50	0	0	0
WHOL SERVICE PAPER	1	35,000	35,000	50	50	0	0	0
WHOL COMPUTERS/SOFTWR	1	20,000	20,000	100	0	0	0	0
WHOL APPLIANCES	1	15,000	15,000	100	0	0	0	0
WHOL PIECE GOODS	1	2,500	2,500	50	50	0	0	0
RET AUTO SUPPLIES	1	1,000	1,000	100	0	0	0	0
RADIOTELEPHONE COMMUN	1	1,000	1,000	100	0	0	0	0
INVESTMENT ADVICE	1	250	250	50	0	50	0	0
LOCAL TRUCK W/STORAGE	1	100	100	100	0	0	0	0
WHOL MISC PROFSN EQPT	1	100	100	100	0	0	0	0

Indications of slowness can be the result of disputes over merchandise, skipped invoices, etc.

Legal Filings and Collections (data source: Experian¹)

Public records have been searched on county, state, and federal levels.

Filing Type	Total Filed	Total Balance	Total Collections	Original Balance	Amount Paid	Balance Remaining
Tax Liens	1	\$16,955	0	\$0	\$0	\$0
Judgments	0	\$0				
UCC Filings	13	n/a				

Credit Rating and Risk Score (data source: Ansonia Credit Data⁵)

Rating: 47K-0

The rating is the average monthly balance and average Days Beyond Terms for the rating period. 24K-32 represents an average monthly balance of \$24,000 with an average Days Beyond Terms of 32 days.

Risk Score: 97

- Low Risk > 87
- Medium Risk 70 - 87
- High Risk < 70

Additional Industry Trade Payment Data By Month (data source: Ansonia Credit Data⁵)

* Months with \$0 balance are not shown.

Trade Payment Experiences				Account Status Days Beyond Terms				Days Beyond Terms
Date Reported	Companies Reporting	Balance	Cur	1-30	31-60	61-90	90+	
07/2020	2	\$3,369	100%					0
06/2020	5	\$22,015	100%					0
05/2020	7	\$49,631	99%					0
04/2020	8	\$44,910	99%					0
03/2020	8	\$51,606	97%	3%				1
02/2020	8	\$50,418	99%	1%				0
01/2020	7	\$51,959	100%					0
12/2019	8	\$30,497	99%					0
11/2019	6	\$41,884	95%	4%				1
10/2019	7	\$74,868	75%	25%				3
09/2019	7	\$113,310	90%	8%	2%			2
08/2019	7	\$131,533	94%	6%				1
07/2019	8	\$81,249	99%	1%				0
06/2019	9	\$51,861	71%	26%	3%			6
05/2019	8	\$53,858	95%	5%				1
04/2019	7	\$45,172	98%	2%				0
03/2019	7	\$46,412	100%					0
02/2019	7	\$29,887	98%		2%			1
01/2019	6	\$39,023	91%	8%				2
12/2018	6	\$41,641	91%	7%	2%			3
11/2018	5	\$32,319	87%	12%				2
10/2018	6	\$56,754	91%	3%	5%			3
09/2018	7	\$82,769	87%	13%				2
08/2018	9	\$89,030	93%	5%	2%			2
07/2018	8	\$72,751	96%	4%				1
06/2018	10	\$50,925	97%	3%				1

Additional Industry Trade Payment Data By Sector (data source: Ansonia Credit Data⁵)

Trade Payment Experiences	Account Status Days Beyond Terms
---------------------------	-------------------------------------

Sales/Service/Questions 800-318-6494 x2242 nathansmith@trustaltus.com www.trustaltus.com

* Information provided in this report has been compiled by a third party vendor, not by Altus.

Altus is not responsible for the accuracy of information provided.

Industry Sector	Date Reported	Companies Reporting	Balance	Cur	1-30	31-60	61-90	90+	Days Beyond Terms
THIRD PARTY LOGISTICS	03/2020	1	\$1,350	100%					0
THIRD PARTY LOGISTICS	02/2020	1	\$1,350	100%					0
THIRD PARTY LOGISTICS	12/2019	1	\$850	100%					0
THIRD PARTY LOGISTICS	09/2019	1	\$1,450	100%					0
THIRD PARTY LOGISTICS	08/2019	1	\$6,980	100%					0
THIRD PARTY LOGISTICS	07/2019	1	\$1,030	100%					0
THIRD PARTY LOGISTICS	06/2019	1	\$350	100%					0
THIRD PARTY LOGISTICS	05/2019	1	\$3,850	100%					0
THIRD PARTY LOGISTICS	04/2019	1	\$1,525	100%					0
THIRD PARTY LOGISTICS	09/2018	1	\$862		100%				15
THIRD PARTY LOGISTICS	08/2018	1	\$862	100%					0
THIRD PARTY LOGISTICS	07/2018	2	\$26,910	100%					0
THIRD PARTY LOGISTICS	06/2018	2	\$8,911	92%	8%				1
LEASING	04/2020	1	\$6,991	100%					0
LEASING	03/2020	1	\$8,435	98%				2%	2
LEASING	02/2020	1	\$7,758	98%				2%	2
LEASING	01/2020	1	\$5,882	97%				3%	3
LEASING	12/2019	1	\$7,006	96%	1%		2%		2
LEASING	11/2019	1	\$7,466	98%		2%			1
LEASING	10/2019	1	\$7,771	98%	2%				0
LEASING	09/2019	1	\$8,790	100%					0
LEASING	08/2019	1	\$9,044	100%					0
LEASING	07/2019	1	\$13,148	99%					1
LEASING	06/2019	1	\$19,324	52%	48%				8
LEASING	05/2019	1	\$9,344	99%		1%			0
LEASING	04/2019	1	\$8,487	99%	1%				0
LEASING	03/2019	1	\$7,630	100%					0
LEASING	02/2019	1	\$7,824	100%					0
LEASING	01/2019	1	\$7,409	100%					0
LEASING	12/2018	1	\$6,207	100%					0
LEASING	10/2018	1	\$7,782	100%					0
LEASING	09/2018	1	\$9,752	100%					0
LEASING	08/2018	1	\$9,847	100%					0
LEASING	07/2018	1	\$8,162	100%					0
LEASING	06/2018	1	\$12,392	100%					0
LESS THAN TRUCKLOAD CARRIER	07/2020	1	\$2,823	100%					0
LESS THAN TRUCKLOAD CARRIER	06/2020	3	\$14,855	100%					0
LESS THAN TRUCKLOAD CARRIER	05/2020	5	\$38,186	99%					0
LESS THAN TRUCKLOAD CARRIER	04/2020	5	\$30,993	99%					0
LESS THAN TRUCKLOAD CARRIER	03/2020	4	\$28,843	95%	5%				1
LESS THAN TRUCKLOAD CARRIER	02/2020	5	\$27,957	98%	2%				0
LESS THAN TRUCKLOAD CARRIER	01/2020	5	\$41,119	100%					0
LESS THAN TRUCKLOAD CARRIER	12/2019	4	\$16,985	100%					0
LESS THAN TRUCKLOAD CARRIER	11/2019	4	\$33,637	95%	5%				1
LESS THAN TRUCKLOAD CARRIER	10/2019	5	\$66,708	72%	28%				4

Account Status
Days Beyond Terms

Trade Payment Experiences

Industry Sector	Date Reported	Companies Reporting	Balance	Cur	Account Status				Days Beyond Terms
					1-30	31-60	61-90	90+	
LESS THAN TRUCKLOAD CARRIER	09/2019	4	\$102,487	89%	9%	3%			3
LESS THAN TRUCKLOAD CARRIER	08/2019	4	\$114,393	94%	6%				1
LESS THAN TRUCKLOAD CARRIER	07/2019	5	\$66,405	99%	1%				0
LESS THAN TRUCKLOAD CARRIER	06/2019	6	\$32,114	82%	13%	6%			4
LESS THAN TRUCKLOAD CARRIER	05/2019	5	\$40,223	93%	7%				1
LESS THAN TRUCKLOAD CARRIER	04/2019	4	\$34,791	97%	3%				0
LESS THAN TRUCKLOAD CARRIER	03/2019	5	\$37,952	100%					0
LESS THAN TRUCKLOAD CARRIER	02/2019	5	\$20,570	97%		3%			2
LESS THAN TRUCKLOAD CARRIER	01/2019	4	\$30,383	89%	11%				2
LESS THAN TRUCKLOAD CARRIER	12/2018	4	\$34,866	89%	8%	2%			3
LESS THAN TRUCKLOAD CARRIER	11/2018	5	\$32,319	87%	12%				2
LESS THAN TRUCKLOAD CARRIER	10/2018	5	\$48,972	90%	4%	6%			3
LESS THAN TRUCKLOAD CARRIER	09/2018	4	\$71,633	86%	14%				2
LESS THAN TRUCKLOAD CARRIER	08/2018	6	\$78,019	93%	5%	2%			2
LESS THAN TRUCKLOAD CARRIER	07/2018	4	\$37,602	93%	7%				1
LESS THAN TRUCKLOAD CARRIER	06/2018	6	\$29,545	97%	3%				1
MANUFACTURING	07/2020	1	\$546	100%					0
MANUFACTURING	06/2020	1	\$546	100%					0
MANUFACTURING	05/2020	1	\$1,148	100%					0
MANUFACTURING	04/2020	1	\$1,298	100%					0
MANUFACTURING	03/2020	1	\$270	100%					0
MANUFACTURING	12/2019	1	\$526	100%					0
MANUFACTURING	11/2019	1	\$781	100%					0
MANUFACTURING	10/2019	1	\$389	100%					0
MANUFACTURING	09/2019	1	\$583	100%					0
MANUFACTURING	08/2019	1	\$1,116	52%	48%				7
MANUFACTURING	07/2019	1	\$666	100%					0
MANUFACTURING	06/2019	1	\$73	100%					0
MANUFACTURING	05/2019	1	\$441	100%					0
MANUFACTURING	04/2019	1	\$369	100%					0
MANUFACTURING	03/2019	1	\$830	100%					0
MANUFACTURING	02/2019	1	\$1,493	100%					0
MANUFACTURING	01/2019	1	\$1,231	100%					0
MANUFACTURING	12/2018	1	\$568	100%					0
MANUFACTURING	09/2018	1	\$522	100%					0
MANUFACTURING	08/2018	1	\$302	100%					0
MANUFACTURING	07/2018	1	\$77		100%				15
MANUFACTURING	06/2018	1	\$77	100%					0
FULL TRUCKLOAD CARRIER	06/2020	1	\$6,614	100%					0
FULL TRUCKLOAD CARRIER	05/2020	1	\$10,297	100%					0
FULL TRUCKLOAD CARRIER	04/2020	1	\$5,628	100%					0
FULL TRUCKLOAD CARRIER	03/2020	1	\$12,708	100%					0
FULL TRUCKLOAD CARRIER	02/2020	1	\$13,353	100%					0

Trade Payment Experiences

Industry Sector	Date Reported	Companies Reporting	Balance	Cur	1-30	31-60	61-90	90+	Days Beyond Terms
FULL TRUCKLOAD CARRIER	01/2020	1	\$4,958	100%					0
FULL TRUCKLOAD CARRIER	12/2019	1	\$5,130	100%					0

Collection Filings

No collection information was found after an extensive search of commercial collection agencies.

Bankruptcies

No bankruptcy information was found after an extensive search of public record data.

Tax Liens

File Date	Filing Type	Status	Amount	Filing Number	Jurisdiction
04/18/2018	STATE TAX	LIEN	\$16,955	201804181033	SACRAMENTO COUNTY RE

Judgments

No judgment or attachment liens were found after an extensive search of public record data.

UCC Filings

Public records have been searched on county, state, and federal levels.

There are 13 UCC filings for this company.

Date Filed	Status	Document Number	Filing Location	Secured Party	Collateral Codes
01/17/2020	FILED	200002390571	SEC OF STATE TX	DE LAGE LANDEN FINANCIAL SERVICES, INC. PA WAYNE 19087 1111	
10/17/2019	CONTINUED	1900395427	SEC OF STATE TX	MOB WOOD GROUP, LLC TX DALLAS 3100 OLYMPUS BLVD., SUIT	
10/15/2019	FILED	190039163062	SEC OF STATE TX	ROWAN CORNILL, INC DBA SUNBELT MATERIAL H TX DALLAS 161	
08/06/2019	FILED	190029879984	SEC OF STATE TX	DE LAGE LANDEN FINANCIAL SERVICES, INC. PA WAYNE 19087 1111	
03/20/2018	FILED	180009547812	SEC OF STATE TX	CEDAR CREEK CORP. TX CARROLLTON 75006 2405 E. BELT LINE ROAD	AFTER ACQUIRED PROP, UNDEFINED
03/15/2017	FILED	170008715675	SEC OF STATE TX	MARQUETTE BUSINESS CREDIT, LLC CA LOS ANGELES 90071 333 S. G	AFTER ACQUIRED PROP, UNDEFINED
01/25/2017	FILED	170002734064	SEC OF STATE TX	CROWN EQUIPMENT CORPORATION OH NEW BREMEN 45869 44 S. WASHIN	EQUIP, AFTER ACQUIRED PROP, UNDEFINED
11/21/2016	TERMINATED	1600381080	SEC OF STATE TX	ATOTECH USA INC. SC ROCK HILL 29730 1750 OVERVIEW DR	
10/17/2016	FILED	51909404	SEC OF STATE NJ	KOMO MACHINE, INC. NJ LAKEWOOD 08701 1 KOMO DRIVE	EQUIP
10/17/2016	TERMINATED	51909404	SEC OF STATE NJ	KOMO MACHINE, INC. NJ LAKEWOOD 08701 1 KOMO DRIVE	
11/17/2015	CONTINUED	1500368399	SEC OF STATE TX	ATOTECH USA INC. SC ROCK HILL 29730 1750 OVERVIEW DR	

Date Filed	Status	Document Number	Filing Location	Secured Party	Collateral Codes
12/03/2014	FILED	140038018722	SEC OF STATE TX	MOB WOOD GROUP INC. TX IRVING 75063 2201 W. ROYAL LANE, SUIT	EQUIP
11/29/2010	FILED	100034062208	SEC OF STATE TX	ATOTECH USA INC. SC ROCK HILL 29730 1750 OVERVIEW DR	UNDEFINED

OFAC Alert

Results for: ARTCO-BELL CORPORATION (ARTCO-BELL)

No OFAC hits found

** The ID numbers listed above are for your benefit to help research with the United States Treasury.*

We are providing the Office of Foreign Assets Control (OFAC) Alert Due Diligence Guide, below, as an aid to facilitate a determination of what further compliance action, if any, should be considered. As a reminder, Client may not use OFAC Alert as part of its decision-making process for determining an individual's eligibility for any credit or any other purpose authorized under the FCRA.

OFAC ALERT DUE DILIGENCE GUIDE

The following guidance is provided for clients receiving OFAC Alert notices indicating some level of match with a person on the OFAC List.

Notices:

- I. Do **NOT** use this Alert to determine an individual's eligibility for any credit or any other purpose authorized under the FCRA. This Alert is **NOT** a consumer report. It is only an Alert for you to take further due diligence steps.
- II. Business Credit Reports assumes no liability for any errors or omissions in this guide. While this guide is intended to facilitate OFAC compliance, its use does not guarantee compliance with applicable law.

Recommended Due Diligence Steps:

- A. Access: <http://www.treasury.gov/resource-center/sanctions/SDN-List/Pages/default.aspx>
- B. Locate the name in question.

Compare the complete OFAC entry with all of the information you have on the subject of your request. An OFAC entry often will have a full name, address, nationality, passport, tax ID or cedula number, place of birth, date of birth, former names and aliases.

If you are missing a lot of this information for your subject, contact the individual or company for additional information and then compare the complete information against the information provided in the OFAC entry.

The following are False Positive Review Standard Match Comparison Guidelines:

- Company Name Match - Compare the words in the Company Names.
 - Name Match - Compare the First and Last Names.
 - Middle Name Match - Compare the Middle Names/Initials.
 - Address Match - Compare Street Addresses.
 - City/State Match - Compare city and state information.
 - Date of Birth - Compare DOB and/or ages, if provided.
 - Spouse - Compare the spouse names if the information is provided.
 - Occupation - Compare the occupation if the information is provided.
 - Suffix/Title/Prefix - Compare the suffix/title/prefix if the information is provided.
- C. Are there a number of similarities or exact matches?
 - If yes, please call the OFAC hotline at [1-800-540-6322](tel:1-800-540-6322).
 - If no, you do not have a valid match. However, if you have reason to know or believe that allowing this person to do business in the United States would violate any of the Department of the Treasury or other Regulations, you should call the OFAC hotline and explain this knowledge or belief.

Much of the above information is from the due diligence steps recommended by the U.S. Department of Treasury for handling and reporting Office of Foreign Assets Control (OFAC) hits. To ensure you have the most recent version of the due diligence steps, please go to: <http://www.treasury.gov/resource-center/sanctions/Pages/regulations.aspx>

¹ Experian data for: ARTCO-BELL CORP, 1302 INDUSTRIAL BLVD, TEMPLE, TX 76504 (Experian File # 784543641 established PRIOR TO JANUARY 1977)

The information herein is furnished in confidence for your exclusive use for legitimate business purposes and shall not be reproduced. Neither Experian Inc. nor its sources or distributors warrant such information nor shall they be liable for your use or reliance upon it.

⁴ D&B data for: ARTCO-BELL CORPORATION, 1302 INDUSTRIAL BLVD, TEMPLE, TX 76504-1126 (DUNS # 072622830)

The information herein is furnished in confidence for your exclusive use for legitimate business purposes and shall not be reproduced. Neither Dun & Bradstreet Inc. nor its sources or distributors warrant such information nor shall they be liable for your use or reliance upon it.

⁵ The information herein is furnished in confidence for your exclusive use for legitimate business purposes and shall not be reproduced. Neither Ansonia Credit Data nor its sources or distributors warrant such information nor shall they be liable for your use or reliance upon it.

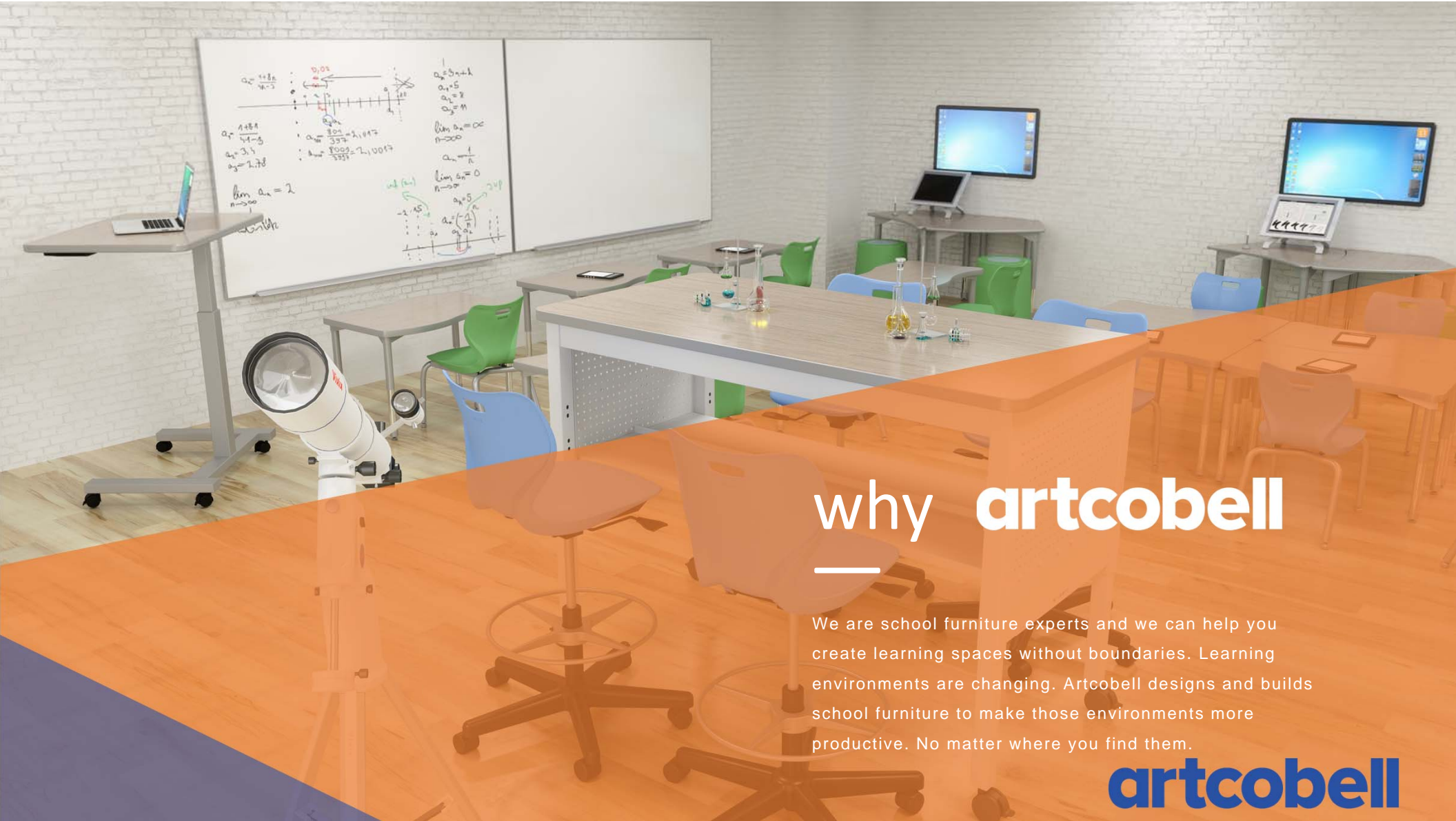

why artcobell

We are school furniture experts and we can help you create learning spaces without boundaries. Learning environments are changing. Artcobell designs and builds school furniture to make those environments more productive. No matter where you find them.

artcobell



#10 Experience

Artcobell has a strong, well-established brand and more than 60 years of experience solely focused on making the best education furniture solutions for all types of learning environments. Our senior leadership team has over 90 years of combined Artcobell experience. Artcobell continuously works with students, teachers, dealers, administrators and specifiers to create flexibility, mobility, and configurability in student spaces, collaboration centers, innovation zones and more.



We are... school furniture experts. We are entirely focused on designing and building furniture that supports teachers and students in today's learning environments. Built on a base of +60 years of manufacturing expertise and led by a team of seasoned pros.

artcobell



#9 Texas Based. USA Made.

From our Temple, Texas manufacturing operation, we turn out thousands of chairs, desks and tables every day. Our vertically integrated plant includes injection molding, metal fabrication, power-coat painting, chrome plating and wood working. Producing the products at our factory rather than importing from overseas allows Artcobell more control over quality assurance and reliable order completion.



Ethical responsibility is our promise at artcobell. We insist on using local suppliers and partners, efficient shipping methods and clean manufacturing processes to make long lasting products. We are an organization that shares its growth and profits with its community.

artcobell



#8 Reliability

Best, most consistent lead times in the industry. Our standard offering is available to our network with a 4-5 week lead time, made to your specifications when your order is placed. We're ready when you are. And that's important when you've got students about to come through the doors.

artcobell

#7 Dedicated Team

An engaged culture of continuous improvement led by more than 300 dedicated employees consistently provides superior customer service and the highest quality products. The average length of employment at Artcobell is over 12 years.





#6 Friendly Approachable

We understand that the conversion to collaborative learning can be overwhelming. We can simplify the process. Let us help you break it down and make a plan you can implement. We're passionate about helping kids learn and teachers teach. We are entirely focused on building furniture that helps teachers teach and students learn.

artcobell

#5 Problem Solvers

Whether you're building a new school or retrofitting an old one, you're juggling demands from many fronts, as well as rigid budgets and timelines. We get that, and we can help you deal with it all.

artcobell





#4 Facilitators

It takes a team to build a school. We can help you navigate the process because we know how to work with administrators, architects and contractors alike.



artcobell

#3 Broad Line of Product Solutions

Artcobell offers a complete line of product solutions including chairs, student desks, tables, and storage units. This allows our customers to coordinate a consistent look throughout their facility and have a single source of responsibility to make sure it's right!



Comfort. Flexibility. Mobility. Creativity.

We're about more than metal, wood and plastic:
we're about creating better learning environments.

artcobell





#2 Ownership

Privately held by a small, local group of industry knowledgeable individuals. They understand the requirements of the school furniture market and are committed to providing the company with what is needed to satisfy Artcobell customers.

artcobell

#1 Local Support

Our locally based, National Dealer Network is the key to a finished job. Whether it's helping with layouts, providing estimates, delivering and installing the finished product, or answering questions after the job is done – this Team is here to make sure each project is a success. From conception to clean-up, our Dealers make the process successful for every customer.

artcobell





How can we help?

At artcobell, service is important to us. If you have any questions, please reach out and start a conversation



CustomerSupport@artcobell.com

1.877.778.1811



artcobell



Trends in Education Design

**the transformation
of teaching and
learning**

A different kind of education



LEARNING
WITHOUT
BOUNDARIES



artcobell



Classroom achievement is influenced by design

artcobell

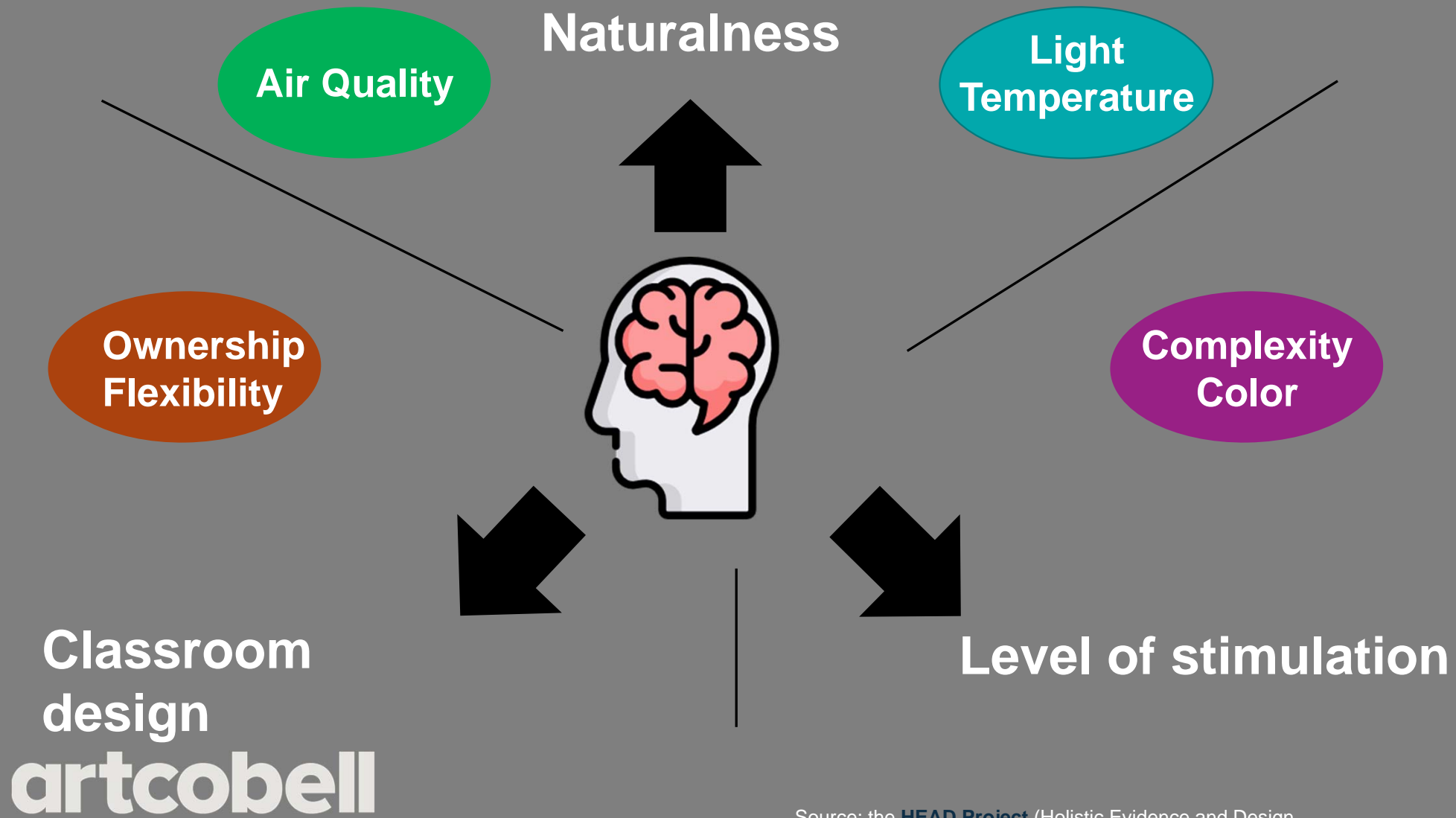

Source: the [HEAD Project](#) (Holistic Evidence and Design)

CLASSROOM DESIGN

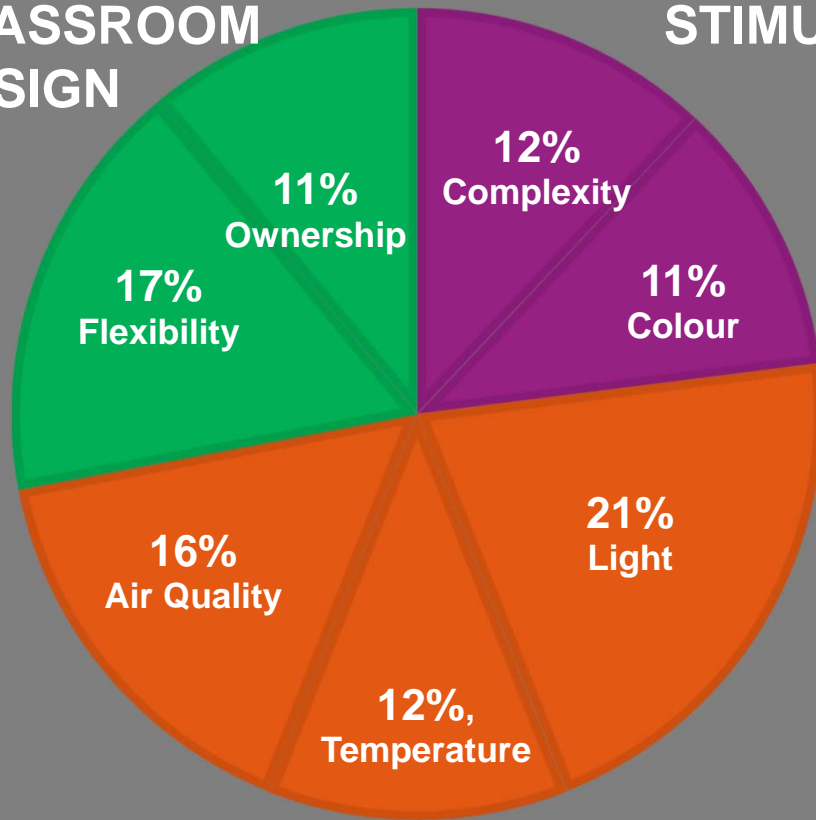

STIMULATION

NATURALNESS

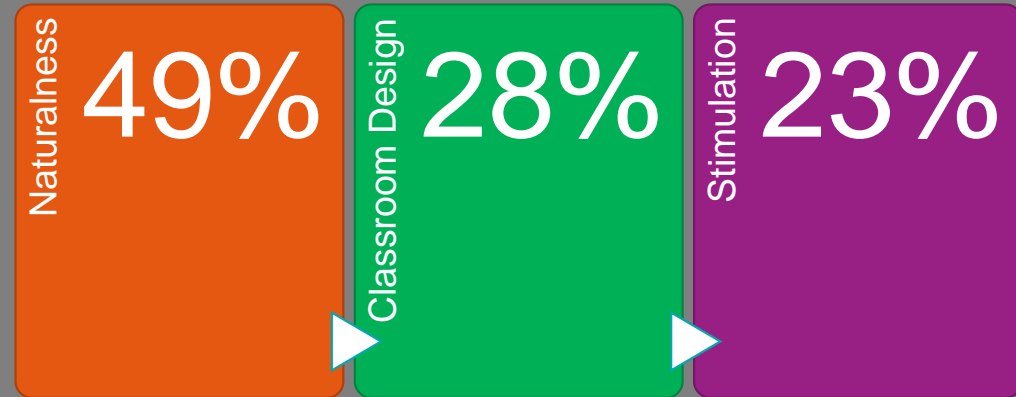

artcobell

HEAD Project (Holistic Evidence and Design), 2015

Naturalness

- Sunlight
- Air quality
- Temperature



artcobell

Stimulation

- Color & Texture
- Sensory complexity



artcobell



Connectedness

- Ownership
- Flexibility

artcobell



Learning Environments for
today's teaching strategies

artcobell

Active Learning Environment

Charles Bonwell *"states that in active learning, students participate in the process of learning and doing something besides passively listening."*



artcobell

Flexible Learning Environment

*“Evolving the classroom space to meet students’ individual needs impacts how they learn, how they interact, and the entire classroom experience.”
(Edutopia, 2015)*



artcobell

Collaborative Learning Environment

“Collaboration is linked to a number of important educational outcomes, including critical thinking, metacognition, and motivation...including the ability to consider multiple perspectives.” (Lai, 2011)

artcobell



Personalized Learning Environment

Amanda Morin writes, “a classroom that doesn’t have a “one size fits all” approach... Students are given options of how and when to demonstrate their mastery... competencies include specific skills, knowledge and mindsets”



artcobell



Learning zones

artcobell



Learning can occur
anywhere at
anytime

Creating zones for learning





Solutions



Take a seat

- ↳ lounge/soft seating for comfort
- ↳ casters for mobility
- ↳ stacking maximizes space
- ↳ Rockers to soothe and provide movement



Work it out



used for presentations
and whiteboarding



expand + evolve the
space by flipping,
moving, nesting



Huddle + Team

—

 small group work

 lounge



Makerspace



heavy duty tables
+ rolling storage
+ performance surfaces



create your own
solution with big
tables on casters



artcobell

Wired for the show



computer stations with
cable management



presentation stations for
group projects and virtual
learning



Connections



**smaller footprint
options**



larger workspace areas



Put it here

—



everything on wheels!



storage that moves,
divides, shapes





when kids feel safe and comfortable...

when they have control over their learning...



more engaged



better participation



improved grades



better communicators



ready for the world



SCHOOL FURNITURE EXPERTS

Learning environments are changing. Artcobell designs and builds classroom furniture to make those environments more productive.

artcobell



THANK YOU.

artcobel

artcobell

ADAPTABLE SOLUTIONS

FOR LEARNING WITHOUT BOUNDARIES



FOR THE REAL-LIFE DEMANDS OF SCHOOLS



At Artcobell, our **only** business is [school furniture](#).

- » We're passionate about designing and building school furniture that supports teachers and students now and into the future. [Our products stand the test of time](#): since 1965, we have consistently produced high value school furniture that holds up to the real-life adventures of day-to-day activity in the classroom and throughout the school.
- » We're **Texas-based, USA made**, and because we're nimble and domestic, we can react quickly to your needs with just-in-time production that is ready to go when you place your order.

Our furniture is stringently tested to meet all the needs of **dynamic, active learning environments**. Everything we make meets or exceeds industry best BIFMA furniture standards and comes with SCS Indoor Advantage Gold IAQ certification. All is backed by our limited lifetime warranty against any manufacturing defects.

Our focus on local suppliers keeps our carbon footprint lower and gives us a reliable source of raw materials, allowing us to offer **competitive pricing** and the **shortest lead times** in the industry – within 4-6 weeks of your order reaching our facility. Our full vertical integration assures we are not dependent on an overseas supply chain. **Controlling our manufacturing destiny guarantees quality, lead times, and the customers' peace of mind.**

An [Artcobell dealer near you](#) is dedicated to making your projects a success, offering project management from design to install and through the first day of school. We work with our dealer network to be:

- » flexible and responsive: uniquely organized to provide personalized solutions and **respond to your needs** quickly and creatively.
- » consistent and reliable: delivering what you need when you need it.
- » trained problem solvers: providing the tools to help schools navigate the demands of selecting the right products to meet today's [learning strategies](#).

TOOLS FOR TEACHING AND LEARNING



[Our products](#) are designed and built based on input from our customers. We listen to teachers and students, administrators and maintenance people.

- » Our promise is to provide solutions to support the teaching and learning today and into the future. Furniture for every educational and curriculum need to enhance Flexible, Collaborative, Personalized and Active environments.
- » Our Learning Environments Leader, a tenured educator/administrator counsels and guides schools in connecting our broad line of solutions to their specific educational needs.

Artcobell offers complete solutions across a range of products: [student desks](#), [tables](#), [seating](#), [soft seating](#), [storage](#) and [more](#).

Comfort is a hallmark of our ergonomically-designed [seating line](#), whether it is traditional poly shell seating solutions like Alphabet and Discover, adaptable seating like [MOV](#) or [Rockers](#) for students who like to wiggle, configurable options like [ARC](#) from our new [soft seating](#) line.

Configurability drives the design of our [Desks](#) and [Tables](#) – allowing teachers and students to build classrooms, from floor to standing height, however and wherever they want.

Creativity can be enabled with extra-heavy-duty [Makerspace cabinets](#) and [tables](#) that are designed to foster exploration with ample workspace and plenty of room to store supplies and equipment.

Coordinate materials, supplies, and space. [Storage solutions](#) are built for mobility, allowing users to configure each space according to needs for access, security, and flexibility.



Made in the U.S.A. Built tough for today's flexible learning environments.
For more info, visit artcobell.com

SCS Global Services does hereby certify that an independent assessment has been conducted on behalf of:

Artcobell

1302 Industrial Boulevard, Temple, TX, United States

For the following product(s):

Screens and Accessories:

Back Pack Hook, CPU Holder, Desk Rail, Desk Rail & Holder Bundle, Device Holder, Dollies, Felt Glide Caps, Grommets, Handheld Marker Board, Maker Space Cabinets, Maker Space Door Kits, Maker Space Trays, Media Holder, Metal Book Box, Mobile Pedestal, MPS Series, PDC Series, Poly Translucent Book Box, Power & Cable Management, Screens, Sliding Keyboard Trays, Solo Glide Caps, Study Carrel Screen, TA Series, Underseat Wire Book Basket, Wire Book Box, Wire Management Trays

The product(s) meets all of the necessary qualifications to be certified for the following claim:

Indoor Advantage™ Gold

Indoor Air Quality Certified to SCS-EC10.3-2014 v4.0

Conforms to the ANSI/BIFMA Furniture Emissions Standard (M7.1/X7.1-2011 R2016) and ANSI/BIFMA e.3 -2019 (Credits 7.6.1, 7.6.2, 7.6.3) for the open plan and private office workstation parameters.¹ Also, conforms to the CDPH/EHLB Standard Method (CA 01350) v1.2-2017 for the open plan and school classroom² parameters.

¹ Modeled as Individual Furniture Components ² Modeled as Pupil Desks

Registration # SCS-IAQ-03679

Valid from: September 10, 2019 to September 9, 2020



A handwritten signature in black ink that reads "Stanley Mathuram".

Stanley Mathuram, PE, Vice President
SCS Global Services
2000 Powell Street, Ste. 600, Emeryville, CA 94608 USA

SCS Global Services does hereby certify that an independent assessment has been conducted on behalf of:

Artcobell

1302 Industrial Boulevard, Temple, TX, United States

For the following product(s):

See Addendum

The product(s) meets all of the necessary qualifications to be certified for the following claim:

Indoor Advantage™ Gold

Indoor Air Quality Certified to SCS-EC10.3-2014 v4.0

Conforms to the ANSI/BIFMA Furniture Emissions Standard (M7.1/X7.1-2011 R2016) and ANSI/BIFMA e.3-2019 (Credits 7.6.1, 7.6.2, 7.6.3) for the open plan and private office workstation parameters.¹ Also, conforms to the CDPH/EHLB Standard Method (CA 01350) v1.2-2017 for the open plan and school classroom² parameters.

¹ Modeled as Individual Furniture Components

² Modeled as Pupil Desks

Registration # SCS-IAQ-03678

Valid from: September 10, 2019 to September 9, 2020



SCSglobal
SERVICES

A handwritten signature in black ink that reads "Stanley Mathuram".

Stanley Mathuram, PE, Vice President
SCS Global Services
2000 Powell Street, Ste. 600, Emeryville, CA 94608 USA

Certification Addendum

Artcobell

Certification: Registration # SCS-IAQ-03678 | Valid from: September 10, 2019 to September 9, 2020

Addendum **Indoor Advantage™ Gold**

Conformance: Indoor Air Quality Certified to SCS-EC10.3-2014 v4.0

Conforms to the ANSI/BIFMA Furniture Emissions Standard (M7.1/X7.1-2011 R2016) and ANSI/BIFMA e.3-2019 (Credits 7.6.1, 7.6.2, 7.6.3) for the open plan and private office workstation parameters.¹ Also, conforms to the CDPH/EHLB Standard Method (CA 01350) v1.2-2017 for the open plan and school classroom² parameters.

¹ Modeled as Individual Furniture Components

² Modeled as Pupil Desks

Products: **Tables/Desking:**

Teacher Desk: ARISE Podium, D Series, E Series, D400 Series, D500 Series, Discover Teacher Desks

Tables: 1500 Series, 1900 Series, 2200 Series, 2300 Series, 3200 Series, 3300 Series, Cafeteria Tables, Computer Tables CT Series, Computer Tables CX Series, Computer Tables CY Series, DCT Series, Discover Tables, Discover Café Table, Discover Multipurpose Tables, Discover Shape Tables, Discover, DTF Series, DTN Series, Cafeteria Tables, Makerspace, Rectangular Convertible Bench Unit, T-Leg Tables, Uniflex 1200 Series | Activity Tables

Student Desks: 1911 Series, 2100 Series, 7A Series, 7KD Series, 7SD Series, 9100 Series, 9500 Series, 9800 Series, Alphabet Four Leg Study Desk, Alphabet Series, Archetype Series, C500 Series, C800 Series, DA Series, Discover D-Series | Open Front Student Desks,

Certification Addendum

Artcobell

Certification: Registration # SCS-IAQ-03678 | Valid from: September 10, 2019 to September 9, 2020

Addendum **Indoor Advantage™ Gold**
Conformance: Indoor Air Quality Certified to SCS-EC10.3-2014 v4.0

Conforms to the ANSI/BIFMA Furniture Emissions Standard (M7.1/X7.1-2011 R2016) and ANSI/BIFMA e.3-2019 (Credits 7.6.1, 7.6.2, 7.6.3) for the open plan and private office workstation parameters.¹ Also, conforms to the CDPH/EHLB Standard Method (CA 01350) v1.2-2017 for the open plan and school classroom² parameters.

¹ Modeled as Individual Furniture Components

² Modeled as Pupil Desks

Products: **Student Desks Continued:**

Discover D-Series | Tri-Top Study Desks, Discover Shape Student Desks, Discover Teacher Desk, Discover T-Leg Study Desk, DST Series, Lift Lid Desks, Prodigy Series, R9 Series, Student Desk 4100 Series | Cantilever Student Desk, Uniflex 2900 Series | Four Leg Study Desk, Uniflex 7 Series | Four Leg Study Desk

SCS Global Services does hereby certify that an independent assessment has been conducted on behalf of:

Artcobell

1302 Industrial Boulevard, Temple, TX, United States

For the following product(s):

See Addendum

The product(s) meets all of the necessary qualifications to be certified for the following claim:

Indoor Advantage™ Gold

Indoor Air Quality Certified to SCS-EC10.3-2014 v4.0

Conforms to the ANSI/BIFMA Furniture Emissions Standard (M7.1/X7.1-2011 R2016) and ANSI/BIFMA e.3 -2019 (Credits 7.6.1, 7.6.2, 7.6.3) for seating parameters.¹ Also, conforms to the CDPH/EHLB Standard Method (CA 01350) v1.2-2017 for seating¹ and school classroom² parameters.

¹ Modeled as Office Seating ² Modeled as Pupil Seating

Registration # SCS-IAQ-03677

Valid from: September 10, 2019 to September 9, 2020



A handwritten signature in black ink that reads "Stanley Mathuram".

Stanley Mathuram, PE, Vice President
SCS Global Services
2000 Powell Street, Ste. 600, Emeryville, CA 94608 USA

Certification Addendum

Artcobell

Certification: Registration # SCS-IAQ-03677 | Valid from: September 10, 2019 to September 9, 2020

Addendum **Indoor Advantage™ Gold**

Conformance: Indoor Air Quality Certified to SCS-EC10.3-2014 v4.0

Conforms to the ANSI/BIFMA Furniture Emissions Standard (M7.1/X7.1-2011 R2016) and ANSI/BIFMA e.3-2019 (Credits 7.6.1, 7.6.2, 7.6.3) for seating parameters.¹ Also, conforms to the CDPH/EHLB Standard Method (CA 01350) v1.2-2017 for seating¹ and school classroom² parameters.

¹ Modeled as Office Seating ² Modeled as Pupil Seating

Products: **Seating:**

Alphabet: Alphabet ASPXL, Alphabet Cantilever Chair, Alphabet Four Leg Caster Chair, Alphabet Four Leg Chair, Alphabet Task Chair & Stool, Alphabet AS4R Rocker, Alphabet ASMOVCVR, Alphabet ASQUBE, Alphabet ASSL Sled Chair, BLOC & STP, MOV Stool, Stool-Four Leg

Discover: Discover D-Series | Four Leg Swivel Stool, Discover D-Series | Gas Lift Swivel Chair & Stool, Discover D000 Series | Sled Stacking Chair, Discover D100 Series | Four Leg Stacking Chair, Discover D100 Series | Four Leg Stacking Music Chair, Discover D200 Series | Tablet Arm Chair Desk, Discover D300 Series | Cantilever Chair, Discover D700 Series | Four Leg Combo Desk,

Certification Addendum

Artcobell

Certification: Registration # SCS-IAQ-03677 | Valid from: September 10, 2019 to September 9, 2020

Addendum **Indoor Advantage™ Gold**

Conformance: Indoor Air Quality Certified to SCS-EC10.3-2014 v4.0

Conforms to the ANSI/BIFMA Furniture Emissions Standard (M7.1/X7.1-2011 R2016) and ANSI/BIFMA e.3-2019 (Credits 7.6.1, 7.6.2, 7.6.3) for seating parameters.¹ Also, conforms to the CDPH/EHLB Standard Method (CA 01350) v1.2-2017 for seating¹ and school classroom² parameters.

¹ Modeled as Office Seating ² Modeled as Pupil Seating

Products: **Discover Continued:**

Discover D800 Series | Sled Combo Desk, Discover DS00 Series | HD Stack Chair, Discover D1R Rocker, Discover DP08

Solid Plastic: Solid Plastic H400 Series | Four Leg Combo Desk, Solid Plastic X-Series | Four Leg Stacking Chair

Uniflex: Plastic Top 08 Series | Four Leg Stool, Uniflex 7100 Series | Four Leg Music Chair, Uniflex 7100 Series | Four Leg Stacking Chair, Uniflex 7400 Series | Four Leg Combo Desk, Uniflex 7800 Series | Sled Combo Desk, Uniflex 7900 Series | Four Leg Swivel Stool, Uniflex Gas Lift Swivel Chair & Lab Stool

The warranty information below is effective on all Artcobell products for orders manufactured after January 1, 2017. For warranty information concerning orders placed prior to January 1, 2017, please refer to the warranty information contained in the published price list of the corresponding year. For additional information relating to warranty, please contact your Customer Service Representative.

Effective July 1, 2020

Artcobell warrants to the original purchaser that its products are free from defects in material and workmanship under normal classroom or commercial use for as long as the life of the product, except as set forth below.

During the warranty period, Artcobell will replace, or at its option, repair locally, repair at its factory, or return the purchase price of any Artcobell brand product manufactured after January 1, 2016 that, upon inspection by Artcobell, is determined to be defective in material or workmanship.

This warranty is subject to the following provisions:

Some natural variations occurring in polypropylene material or other natural materials are inherent to their character and are not considered defects. Artcobell does not warrant the colorfastness or matching of colors, grains, or textures of these materials. Customer's Own Material (COM) selected by and used at the request of an original purchaser is not warranted.

Our products are intended for interior use — exterior use of them will void the warranty.

The materials and components listed below are covered from the date of sale according to the following:

- Seating controls, glides, pneumatic cylinders, casters, chroming and polymer-based components and foam – 3 years
- User-adjustable worksurface mechanisms, tablet arm mechanisms, lounge products, occasional tables, seating upholstery fabrics and vinyls and other covering materials – 3 years

Soft seating products manufactured by artcobell are warranted to be free of defects in material and workmanship under normal use for the lifetime of the product. Product must be properly cared for, maintained and in use by its original owner. Under the warranty, the obligation of artcobell is limited to the repair or replacement of such furniture. Damage in transit or by negligence, abuse, abnormal usage, misuse, accidents or alterations nullifies the warranty.

As Buyer's sole remedy under this warranty, artcobell, at its option, will repair or replace damaged parts at no charge to the original owner of record provided the replacement or return has previously been authorized by artcobell under

terms of this warranty. Normal aging and wear of fabrics, filling materials, and finishes are excepted from this warranty. It is expressly agreed that this remedy of repair, replacement or credit, at artcobell's option, is Buyer's exclusive remedy under this warranty. In no event shall Seller be liable for consequential damages.

This warranty does not apply to:

- Normal wear and tear
- Damage from environmental factors
- Damage from sharp objects (e.g., writing utensils, heeled shoes, scissors, jewelry, and keys)
- Damage from accident, alteration, misuse, or improper installation or maintenance
- Modifications or attachments to the product not approved by Artcobell
- Products used for rental purposes
- Damage caused by the carrier in-transit, which is handled under separate terms
- Third-party products – Artcobell, to the extent possible, will pass through to the original purchaser (and process claims under) any warranty provided by third-party products supplied to Artcobell.
- All warranty claims are to be made in writing by the original purchaser. The original purchaser may be required to produce the invoice or other evidence to establish that a claim is within the warranty period.

Damage to flooring (dimpling, indentation or similar) is not covered. Warranty as to the suitability of flooring used with school furniture glides and caster rests solely with the flooring manufacturer.

To the extent allowed by law, Artcobell makes no other warranty, either express or implied, including any warranty or merchantability or fitness for a particular purpose. Artcobell is not liable for any indirect consequential or incidental damages. This warranty contains the original purchaser's exclusive remedy.

Your Artcobell Dealer is our resource in supporting your warranty requests. To obtain service under this warranty, please contact your Artcobell Dealer.



CERTIFICATE OF LIABILITY INSURANCE

DATE (MM/DD/YYYY)

7/6/2020

THIS CERTIFICATE IS ISSUED AS A MATTER OF INFORMATION ONLY AND CONFERS NO RIGHTS UPON THE CERTIFICATE HOLDER. THIS CERTIFICATE DOES NOT AFFIRMATIVELY OR NEGATIVELY AMEND, EXTEND OR ALTER THE COVERAGE AFFORDED BY THE POLICIES BELOW. THIS CERTIFICATE OF INSURANCE DOES NOT CONSTITUTE A CONTRACT BETWEEN THE ISSUING INSURER(S), AUTHORIZED REPRESENTATIVE OR PRODUCER, AND THE CERTIFICATE HOLDER.

IMPORTANT: If the certificate holder is an ADDITIONAL INSURED, the policy(ies) must have ADDITIONAL INSURED provisions or be endorsed. If SUBROGATION IS WAIVED, subject to the terms and conditions of the policy, certain policies may require an endorsement. A statement on this certificate does not confer rights to the certificate holder in lieu of such endorsement(s).

PRODUCER Arthur J. Gallagher & Co. Insurance Brokers of CA 505 N Brand Boulevard Suite 600 Glendale CA 91203	CONTACT NAME: Kris Manukyan PHONE (A/C. No. Ext): 818-539-1337 E-MAIL ADDRESS: Kris_Manukyan@ajg.com		FAX (A/C. No): 818-539-1637
	INSURER(S) AFFORDING COVERAGE		
INSURED KICKBALL SUPER HOLDINGS, LLC ARTCO BELL CORPORATION 1302 Industrial Blvd Temple TX 76504	INSURER A : Travelers Property Casualty Co of America		NAIC # 25674
	INSURER B : Phoenix Insurance Company		25623
	INSURER C : The Travelers Indemnity Company of CT		25682
	INSURER D : Travelers Commercial Insurance Company		36137
	INSURER E :		
	INSURER F :		

COVERAGES

CERTIFICATE NUMBER: 1966532981

REVISION NUMBER:

THIS IS TO CERTIFY THAT THE POLICIES OF INSURANCE LISTED BELOW HAVE BEEN ISSUED TO THE INSURED NAMED ABOVE FOR THE POLICY PERIOD INDICATED. NOTWITHSTANDING ANY REQUIREMENT, TERM OR CONDITION OF ANY CONTRACT OR OTHER DOCUMENT WITH RESPECT TO WHICH THIS CERTIFICATE MAY BE ISSUED OR MAY PERTAIN, THE INSURANCE AFFORDED BY THE POLICIES DESCRIBED HEREIN IS SUBJECT TO ALL THE TERMS, EXCLUSIONS AND CONDITIONS OF SUCH POLICIES. LIMITS SHOWN MAY HAVE BEEN REDUCED BY PAID CLAIMS.

INSR LTR	TYPE OF INSURANCE	ADDL INSD	SUBR WVD	POLICY NUMBER	POLICY EFF (MM/DD/YYYY)	POLICY EXP (MM/DD/YYYY)	LIMITS
C	<input checked="" type="checkbox"/> COMMERCIAL GENERAL LIABILITY <input type="checkbox"/> CLAIMS-MADE <input checked="" type="checkbox"/> OCCUR GEN'L AGGREGATE LIMIT APPLIES PER: <input checked="" type="checkbox"/> POLICY <input type="checkbox"/> PRO-JECT <input type="checkbox"/> LOC OTHER:	Y	Y	630-9H775308-IND-19	12/31/2019	12/31/2020	EACH OCCURRENCE \$ 1,000,000 DAMAGE TO RENTED PREMISES (Ea occurrence) \$ 300,000 MED EXP (Any one person) \$ 25,000 PERSONAL & ADV INJURY \$ 1,000,000 GENERAL AGGREGATE \$ 2,000,000 PRODUCTS - COMP/OP AGG \$ 2,000,000 \$
A	AUTOMOBILE LIABILITY <input checked="" type="checkbox"/> ANY AUTO <input type="checkbox"/> OWNED AUTOS ONLY <input type="checkbox"/> SCHEDULED AUTOS <input checked="" type="checkbox"/> HIRED AUTOS ONLY <input checked="" type="checkbox"/> NON-OWNED AUTOS ONLY			BA-9N733933-19-CAG	12/31/2019	12/31/2020	COMBINED SINGLE LIMIT (Ea accident) \$ 1,000,000 BODILY INJURY (Per person) \$ BODILY INJURY (Per accident) \$ PROPERTY DAMAGE (Per accident) \$ \$
D	<input type="checkbox"/> UMBRELLA LIAB <input checked="" type="checkbox"/> OCCUR <input checked="" type="checkbox"/> EXCESS LIAB <input type="checkbox"/> CLAIMS-MADE DED <input checked="" type="checkbox"/> RETENTION \$ 0			CUP-0N629246-19-14	12/31/2019	12/31/2020	EACH OCCURRENCE \$ 1,000,000 AGGREGATE \$ 1,000,000 \$
B	WORKERS COMPENSATION AND EMPLOYERS' LIABILITY ANY PROPRIETOR/PARTNER/EXECUTIVE OFFICER/MEMBER EXCLUDED? (Mandatory in NH) If yes, describe under DESCRIPTION OF OPERATIONS below	Y/N	N/A	UB-9H78884A-19-14	12/31/2019	12/31/2020	<input checked="" type="checkbox"/> PER STATUTE <input type="checkbox"/> OTH-ER E.L. EACH ACCIDENT \$ 1,000,000 E.L. DISEASE - EA EMPLOYEE \$ 1,000,000 E.L. DISEASE - POLICY LIMIT \$ 1,000,000

DESCRIPTION OF OPERATIONS / LOCATIONS / VEHICLES (ACORD 101, Additional Remarks Schedule, may be attached if more space is required)

RFP #EQ-052920-01

Public Opening Location: Region 10 ESC, 400 E Spring Valley Road, Richardson, TX 75081

10 day notice of cancellation for non payment of premium.

Certificate Holder is named as an additional insured under the liability section per attached policy form #CG D4580713

CERTIFICATE HOLDER**CANCELLATION**
 Education Service Center, Region 10
 400 E Spring Valley Rd
 Richardson TX 75081

SHOULD ANY OF THE ABOVE DESCRIBED POLICIES BE CANCELLED BEFORE THE EXPIRATION DATE THEREOF, NOTICE WILL BE DELIVERED IN ACCORDANCE WITH THE POLICY PROVISIONS.

AUTHORIZED REPRESENTATIVE

© 1988-2015 ACORD CORPORATION. All rights reserved.



EVIDENCE OF COMMERCIAL PROPERTY INSURANCE

DATE (MM/DD/YYYY)

7/6/2020

THIS EVIDENCE OF COMMERCIAL PROPERTY INSURANCE IS ISSUED AS A MATTER OF INFORMATION ONLY AND CONFERS NO RIGHTS UPON THE ADDITIONAL INTEREST NAMED BELOW. THIS EVIDENCE DOES NOT AFFIRMATIVELY OR NEGATIVELY AMEND, EXTEND OR ALTER THE COVERAGE AFFORDED BY THE POLICIES BELOW. THIS EVIDENCE OF INSURANCE DOES NOT CONSTITUTE A CONTRACT BETWEEN THE ISSUING INSURER(S), AUTHORIZED REPRESENTATIVE OR PRODUCER, AND THE ADDITIONAL INTEREST.

PRODUCER NAME, CONTACT PERSON AND ADDRESS Arthur J. Gallagher & Co. Insurance Brokers of CA 505 N Brand Boulevard Suite 600 Glendale, CA 91203		PHONE (A/C, No, Ext): 818-539-1337	COMPANY NAME AND ADDRESS The Travelers Indemnity Company of CT One Tower Square Hartford, CT 06183		NAIC NO: 25682
FAX (A/C, No): 818-539-1637		E-MAIL ADDRESS: kris_Manukyan@ajg.com		IF MULTIPLE COMPANIES, COMPLETE SEPARATE FORM FOR EACH	
CODE: AGENCY CUSTOMER ID #:		SUB CODE:		POLICY TYPE	
NAMED INSURED AND ADDRESS KICKBALL SUPER HOLDINGS, LLC ARTCO BELL CORPORATION 1302 Industrial Blvd Temple, TX 76504		LOAN NUMBER		POLICY NUMBER 630-9H775308-IND-19	
ADDITIONAL NAMED INSURED(S)		EFFECTIVE DATE 12/31/2019		EXPIRATION DATE 12/31/2020	
				<input type="checkbox"/> CONTINUED UNTIL TERMINATED IF CHECKED	
		THIS REPLACES PRIOR EVIDENCE DATED:			

PROPERTY INFORMATION (ACORD 101 may be attached if more space is required) BUILDING OR BUSINESS PERSONAL PROPERTY

LOCATION/DESCRIPTION Loc# 1, Bldg# 1: 1302 Industrial Blvd, Temple, TX 76504 Loc# 2, Bldg# 1: 2526 Charter Oak Dr., Temple, TX 76502	
THE POLICIES OF INSURANCE LISTED BELOW HAVE BEEN ISSUED TO THE INSURED NAMED ABOVE FOR THE POLICY PERIOD INDICATED. NOTWITHSTANDING ANY REQUIREMENT, TERM OR CONDITION OF ANY CONTRACT OR OTHER DOCUMENT WITH RESPECT TO WHICH THIS EVIDENCE OF PROPERTY INSURANCE MAY BE ISSUED OR MAY PERTAIN, THE INSURANCE AFFORDED BY THE POLICIES DESCRIBED HEREIN IS SUBJECT TO ALL THE TERMS, EXCLUSIONS AND CONDITIONS OF SUCH POLICIES. LIMITS SHOWN MAY HAVE BEEN REDUCED BY PAID CLAIMS.	

COVERAGE INFORMATION		PERILS INSURED	BASIC	BROAD	<input checked="" type="checkbox"/>	SPECIAL	
COMMERCIAL PROPERTY COVERAGE AMOUNT OF INSURANCE:		\$ see remarks				DED:25,000	
		YES	NO	N/A			
<input checked="" type="checkbox"/> BUSINESS INCOME	<input type="checkbox"/> RENTAL VALUE	X			If YES, LIMIT: see remarks	Actual Loss Sustained; # of months:	
BLANKET COVERAGE		X			If YES, indicate value(s) reported on property identified above: \$		
TERRORISM COVERAGE		X			Attach Disclosure Notice / DEC		
IS THERE A TERRORISM-SPECIFIC EXCLUSION?		X					
IS DOMESTIC TERRORISM EXCLUDED?		X					
LIMITED FUNGUS COVERAGE			X		If YES, LIMIT:	DED:	
FUNGUS EXCLUSION (If "YES", specify organization's form used)		X					
REPLACEMENT COST		X					
AGREED VALUE		X					
COINSURANCE			X		If YES, %		
EQUIPMENT BREAKDOWN (If Applicable)		X			If YES, LIMIT:	DED:	
ORDINANCE OR LAW - Coverage for loss to undamaged portion of bldg		X			If YES, LIMIT: 1,000,000	DED:	
- Demolition Costs				X	If YES, LIMIT:	DED:	
- Incr. Cost of Construction				X	If YES, LIMIT:	DED:	
EARTH MOVEMENT (If Applicable)			X		If YES, LIMIT:	DED:	
FLOOD (If Applicable)			X		If YES, LIMIT:	DED:	
WIND / HAIL INCL <input checked="" type="checkbox"/> YES <input type="checkbox"/> NO Subject to Different Provisions:		X			If YES, LIMIT:	DED:100,000	
NAMED STORM INCL <input type="checkbox"/> YES <input type="checkbox"/> NO Subject to Different Provisions:				X	If YES, LIMIT:	DED:	
PERMISSION TO WAIVE SUBROGATION IN FAVOR OF MORTGAGE HOLDER PRIOR TO LOSS				X			

CANCELLATION SHOULD ANY OF THE ABOVE DESCRIBED POLICIES BE CANCELLED BEFORE THE EXPIRATION DATE THEREOF, NOTICE WILL BE DELIVERED IN ACCORDANCE WITH THE POLICY PROVISIONS.	
---	--

ADDITIONAL INTEREST		
<input type="checkbox"/> CONTRACT OF SALE <input type="checkbox"/> MORTGAGEE	<input type="checkbox"/> LENDER'S LOSS PAYABLE <input type="checkbox"/> LOSS PAYEE	LENDER SERVICING AGENT NAME AND ADDRESS AUTHORIZED REPRESENTATIVE 
NAME AND ADDRESS Education Service Center, Region 10 400 E Spring Valley Rd Richardson, TX 75081		

© 2003-2015 ACORD CORPORATION. All rights reserved.



ADDITIONAL REMARKS SCHEDULE

AGENCY Arthur J. Gallagher & Co. Insurance Brokers of CA		NAMED INSURED KICKBALL SUPER HOLDINGS, LLC ARTCO BELL CORPORATION 1302 Industrial Blvd Temple, TX 76504	
POLICY NUMBER 630-9H775308-IND-19		EFFECTIVE DATE: 12/31/2019	
CARRIER The Travelers Indemnity Company of CT	NAIC CODE 25682		

ADDITIONAL REMARKS

THIS ADDITIONAL REMARKS FORM IS A SCHEDULE TO ACORD FORM,
FORM NUMBER: 28 **FORM TITLE:** EVIDENCE OF COMMERCIAL PROPERTY INSURANCE

REMARKS:

RFP #EQ-052920-01
 Public Opening Location: Region 10 ESC, 400 E Spring Valley Road, Richardson, TX 75081
 10 day notice of cancellation for non payment of premium

Appendix E: VENDOR CONTRACT AND SIGNATURE FORM

This Vendor Contract and Signature Form ("Contract") is made as of _____, by and between _____
Artcobell Corporation ("Vendor") and Region 10 Education Service Center ("Region
10 ESC") for the purchase of Furniture and Storage, related products and services ("the products and services").

RECITALS

WHEREAS, both parties agree and understand that the following pages will constitute the contract between the successful vendor(s) and Region 10 ESC, having its principal place of business at **Education Service Center, Region 10, 400 E Spring Valley Rd, Richardson, TX 75081**

WHEREAS, Vendor agrees to include, in writing, any required exceptions or deviations from these terms, conditions, and specifications; and it is further understood that if agreed to by Region 10 ESC, said exceptions or deviations will be incorporated into the final contract "Vendor Contract."

WHEREAS, this contract consists of the provisions set forth below, including provisions of all attachments referenced herein. In the event of a conflict between the provisions set forth below and those contained in any attachment, the provisions set forth below shall control.

WHEREAS, the Vendor Contract will provide that any state, county, special district, local government, school district, private K-12 school, technical or vocational school, higher education institution (including community colleges, colleges and universities, both public and private), other government agencies or non-profit organization may purchase products and services at prices indicated in the Vendor Contract upon registering and becoming a member with Region 10 ESC; and it being further understood that Region 10 ESC shall act as the Lead Agency with respect to all such purchase agreements.

WHEREAS, Equalis Group has the administrative and legal capacity to administer purchases on behalf of Region 10 ESC under the Vendor Contract with participating public agencies and entities, as permitted by applicable law.

ARTICLE 1- GENERAL TERMS AND CONDITIONS

1.1 Equalis Group shall be afforded all of the rights, privileges and indemnifications afforded to Region 10 ESC under the Vendor Contract, and such rights, privileges and indemnifications shall accrue and apply with equal effect to Equalis Group, including, without limitation, Vendor's obligation to provide insurance and other indemnifications to Lead Agency.

1.2 Awarded vendor shall perform all duties, responsibilities and obligations, set forth in this agreement, and required under the Vendor Contract.

1.3 Equalis Group shall perform its duties, responsibilities and obligations as administrator of purchases, set forth in this agreement, and required under the Vendor Contract.

1.4 **Customer Support:** The vendor shall provide timely and accurate technical advice and sales support to Region 10 ESC staff, Equalis Group staff and participating agencies. The vendor shall respond to such requests within one (1) working day after receipt of the request.

ARTICLE 2- ANTICIPATED TERM OF AGREEMENT

- Term:** The term of the Contract shall commence upon award and shall remain in effect for a period of three (3) years, unless terminated, canceled or extended as otherwise provided herein. The Contractor agrees that Region 10 ESC shall have the right, at its sole option, to renew the Contract for four (4) additional one-year periods or portions thereof. In the event that Region 10 ESC exercises such rights, all terms, conditions and provisions of the original Contract shall remain the same and apply during the renewal period with the possible exception of price and minor scope additions and/or deletions.
- Automatic Renewal:** Renewal will take place automatically for one (1) year unless Region 10 ESC gives written notice to the awarded supplier at least ninety (90) days prior to the expiration.

ARTICLE 3- REPRESENTATIONS AND COVENANTS

Scope: This contract is based on the need to provide the economic benefits of volume purchasing and reduction in administrative costs through cooperative purchasing to schools and other members.

Compliance: Cooperative Purchasing Agreements between Equalis Group and its Members have been established under state procurement law.

Respondent's promise: Respondent agrees all prices, terms, warranties, and benefits granted by Respondent to Members through this contract are comparable to or better than the equivalent terms offered by Respondent to any present customer meeting the same qualifications or requirements.

ARTICLE 4- FORMATION OF CONTRACT

4.1. **Respondent contract documents:** Region 10 ESC will review proposed Respondent contract documents. Vendor's contract document shall not become part of Region 10 ESC's contract with vendor unless and until an authorized representative of Region 10 ESC reviews and approves it.

4.2. **Form of contract:** The form of contract for this solicitation shall be the Request for Proposal, the awarded proposal(s) to the lowest responsible Respondent(s), and properly issued and reviewed purchase orders referencing the requirements of the Request for Proposal. If a firm submitting a proposal requires Region 10 ESC and/or Member to sign an additional agreement, a copy of the proposed agreement must be included with the proposal.

4.3. **Entire Agreement (Parol evidence):** The contract, as specified above, represents the final written expression of agreement. All agreements are contained herein and no other agreements or representations that materially alter it are acceptable.

4.4. **Assignment of Contract:** No assignment of contract may be made without the prior written approval of Region 10 ESC. Purchase orders and payment can only be made to awarded vendor unless otherwise approved by Region 10 ESC. Awarded vendor is required to notify Region 10 ESC when any material change in operations is made that may adversely affect members (i.e. awarded vendor bankruptcy, change of ownership, merger, etc.).

4.5. **Contract Alterations:** No alterations to the terms of this contract shall be valid or binding unless authorized and signed with a “wet signature” by a Region 10 ESC staff member.

4.6. **Order of precedence:** In the event of a conflict in the provisions of the contract as accepted by Region 10 ESC, the following order of precedence shall prevail:

- Special terms and conditions
- General terms and conditions
- Specifications and scope of work
- Attachments and exhibits
- Documents referenced or included in the solicitation

4.8 **Supplemental Agreements:** The entity participating in the Region 10 ESC contract and awarded vendor may enter into a separate supplemental agreement to further define the level of service requirements over and above the minimum defined in this contract i.e. invoice requirements, ordering requirements, specialized delivery, etc. Any supplemental agreement developed as a result of this contract is exclusively between the participating entity and awarded vendor. Neither Region 10 ESC, Equalis Group, its agents, members and employees shall be made party to any claim for breach of such agreement.

ARTICLE 5- TERMINATION OF CONTRACT

5.1. **Cancellation for non-performance or contractor deficiency:** Region 10 ESC may terminate any contract if Members have not used the contract, or if purchase volume is determined to be low volume in any 12-month period. Region 10 ESC reserves the right to cancel the whole or any part of this contract due to failure by contractor to carry out any obligation, term or condition of the contract. Region 10 ESC may issue a written deficiency notice to contractor for acting or failing to act in any of the following:

- i. Providing material that does not meet the specifications of the contract;
- ii. Providing work and/or material that was not awarded under the contract;
- iii. Failing to adequately perform the services set forth in the scope of work and specifications;
- iv. Failing to complete required work or furnish required materials within a reasonable amount of time;
- v. Failing to make progress in performance of the contract and/or giving Region 10 ESC reason to believe that contractor will not or cannot perform the requirements of the contract; and/or
- vi. Performing work or providing services under the contract prior to receiving a Region 10 ESC reviewed purchase order for such work.

Upon receipt of a written deficiency notice, contractor shall have ten (10) days to provide a satisfactory response to Region 10 ESC. Failure to adequately address all issues of concern may result in contract cancellation. Upon cancellation under this paragraph, all goods, materials, work, documents, data and reports prepared by contractor under the contract shall become the property of the Member on demand.

5.2 **Termination for cause:** If, for any reason, the Vendor fails to fulfill its obligation in a timely manner, or if the vendor violates any of the covenants, agreements, or stipulations of this contract, Region 10 ESC reserves the right to terminate the contract immediately and pursue all other applicable remedies afforded by law. Such termination shall be effective by delivery of notice, to the vendor, specifying the effective date of termination. In such event, all documents, data, studies, surveys, drawings, maps, models and reports prepared by vendor for this solicitation may become the property of the participating agency or entity. If such event does occur then vendor will be entitled to receive just and equitable compensation for the satisfactory work completed on such documents.

5.3 **Delivery/Service failures:** Failure to deliver goods or services within the time specified or within a reasonable time period as interpreted by the purchasing agent, or failure to make replacements or corrections of rejected articles/services when so requested shall constitute grounds for the contract to be terminated. In the event that the participating agency or entity must purchase in an open market, contractor agrees to reimburse the participating agency or entity, within a reasonable time period, for all expenses incurred.

5.4 **Force Majeure:** If by reason of Force Majeure, either party hereto shall be rendered unable wholly or in part to carry out its obligations under this Agreement then such party shall give notice and full particulars of Force Majeure in writing to the other party within a reasonable time after occurrence of the event or cause relied upon, and the obligation of the party giving such notice, so far as it is affected by such Force Majeure, shall be suspended during the continuance of the inability then claimed, except as hereinafter provided, but for no longer period, and such party shall endeavor to remove or overcome such inability with all reasonable dispatch.

The term Force Majeure as employed herein, shall mean acts of God, strikes, lockouts, or other industrial disturbances, act of public enemy, orders of any kind of government of the United States or the State of Texas or any civil or military authority; insurrections; riots; epidemics; landslides; lighting; earthquake; fires; hurricanes; storms; floods; washouts; droughts; arrests; restraint of government and people; civil disturbances; explosions, breakage or accidents to machinery, pipelines or canals, or other causes not reasonably within the control of the party claiming such inability. It is understood and agreed that the settlement of strikes and lockouts shall be entirely within the discretion of the party having the difficulty, and that the above requirement that any Force Majeure shall be remedied with all reasonable dispatch shall not require the settlement of strikes and lockouts by acceding to the demands of the opposing party or parties when such settlement is unfavorable in the judgment of the party having the difficulty

5.5 **Standard Cancellation:** Either party may cancel this contract in whole or in part by providing written notice. The cancellation will take effect 90 business days after the other party receives the notice of cancellation. After the 90th business day all work will cease following completion of final purchase order. Region 10 ESC reserves the right to request additional items not already on contract at any time.

ARTICLE 6- LICENSES

6.1 **Duty to keep current license:** Vendor shall maintain in current status all federal, state and local licenses, bonds and permits required for the operation of the business conducted by vendor. Vendor shall remain fully informed of and in compliance with all ordinances and regulations pertaining to the lawful provision of services under the contract. Region 10 ESC reserves the right to stop work and/or cancel the contract of any vendor whose license(s) expire, lapse, are suspended or terminated.

6.2 **Suspension or Debarment:** Respondent shall provide a letter in the proposal notifying Region 10 ESC of any debarment, suspension or other lawful action taken against them by any federal, state, or local government within the last five (5) years that precludes Respondent or its employees from participating in any public procurement activity. The letter shall state the duration of the suspension or action taken, the relevant circumstances and the name of the agency imposing the suspension. Failure to supply or disclose this information may be grounds for cancellation of contract.

6.3 **Survival Clause:** All applicable software license agreements, warranties or service agreements that were entered into between Vendor and Customer/participating member under the terms and conditions of the Contract shall survive the expiration or termination of the Contract. All Purchase Orders issued and accepted by Order Fulfiller shall survive expiration or termination of the Contract.

ARTICLE 7- DELIVERY PROVISIONS

7.1 **Delivery:** Vendor shall deliver said materials purchased on this contract to the participating member issuing a Purchase Order. Conforming product shall be shipped within 7 days of receipt of Purchase Order. If delivery is not or cannot be made within this time period the vendor must receive authorization from the purchasing agency for the delayed delivery. At this point the participating entity may cancel the order if estimated shipping time is not acceptable.

7.2 **Inspection & Acceptance:** If defective or incorrect material is delivered, purchasing agency may make the determination to return the material to the vendor at no cost to the purchasing agency. The vendor agrees to pay all shipping costs for the return shipment. Vendor shall be responsible for arranging the return of the defective or incorrect material.

7.3 **Responsibility for supplies tendered:** Vendor shall be responsible for the materials or supplies covered by this contract until they are delivered to the designated delivery point.

7.4 **Shipping Instructions:** Unless otherwise specified, each case, crate, barrel, package, etc, delivered under this contract must be plainly labeled, securely tagged, stating Vendor's name, purchase order number, quantity contained therein, and delivery address as indicated in the order. Deliveries must be made within the hours of 8:00 am – 4:00 pm. Deliveries at any other time (including Saturdays, Sundays and holidays) will not be accepted unless arrangements have been made in advance with the receiver at the delivery point. Vendor understands that it is their responsibility to ensure compliance with the delivery instructions outlined in this agreement.

7.5 **Additional charges:** Unless bought on F.O.B. "shipping point" and Vendor prepays transportation, no delivery charges shall be added to invoices except when express delivery is authorized and substituted on orders for the method specified in the contract. In such cases, the difference between freight or mail and express charges may be added to the invoice.

7.6 **Buyer's delays:** Region 10 ESC will not be responsible for any late fees due the prime contractor by the participating member. The prime contractor will negotiate with the participating agency for the recovery of damages related to expenses incurred by the vendor for a delay for which the Region 10 ESC member is responsible, which is unreasonable, and which was not within the contemplation of the parties to the contract between the two parties.

ARTICLE 8- BILLING AND REPORTING

8.1 **Payments:** The participating entity using the contract will make payments directly to the awarded vendor.

Payment shall be made after satisfactory performance, in accordance with all provisions thereof, and upon receipt of a properly completed invoice.

8.2 **Tax Exempt Status:** Since this is a national contract, knowing the tax laws in each state is the sole responsibility of the Vendor.

8.3 **Reporting:** Vendor shall electronically provide Equalis Group with a detailed line item monthly report showing the dollar volume of all member product sales under the contract for the previous month. Reports shall be sent via e-mail to Equalis Group offices at info@equalisgroup.org. Reports are due on the **fifteenth (15th)** day after the close of the previous month. It is the responsibility of the awarded vendor to collect and compile all sales under the contract from participating members and submit one (1) report. Fields below marked as *required indicate a required field. All other fields are preferred, but not required:

Member Data	Equalis Member ID
	Vendor Customer Number *required (or Equalis Member ID)
	Customer Name *required
	Customer Street Address *required
	Customer City *required
	Customer Zip Code *required
	Customer State *required
Distributor Data	Distributor Name
	Distributor ID
	Distributor Street Address
	Distributor City
	Distributor Zip Code
	Distributor State
Product Data	Product Category level 1
	Distributor Product Number
	Manufacturer Product Number
	Product Description
	Product Brand Name
	Product packaging Unit of Measure level 1
	Product packaging Unit of Measure level 2
	Product packaging Unit of Measure level 3
Spend Data	Purchase Unit of Measure
	Purchase Quantity
	Distributor Landed Cost Total \$ (without deviations)
	Distributor Landed Cost Total \$ (with mfr deviations)
	Customer Purchase Total \$ *required

	Admin Fee % *required
	Admin Fee \$ *required

ARTICLE 9- PRICING

9.1 **Market competitive guarantee:** Vendor agrees to provide market competitive pricing, based on the value offered upon award, to Region 10 ESC and its participating public agencies throughout the duration of the contract.

9.2 **Price increase:** Should it become necessary or proper during the term of this contract to make any change in design or any alterations that will increase expense, Region 10 ESC must be notified immediately. Price increases must be approved by Lead Agency and no payment for additional materials or services, beyond the amount stipulated in the contract, shall be paid without prior approval. All price increases must be supported by manufacture documentation, or a formal cost justification letter.

Vendor must honor previous prices for thirty (30) days after approval and written notification from Region 10 ESC if requested.

It is Vendor’s responsibility to keep all pricing up to date and on file with Region 10 ESC. All price changes must be provided to Region 10 ESC, using the same format as was accepted in the original contract.

9.3 **Additional Charges:** All deliveries shall be freight prepaid, F.O.B. destination and shall be included in all pricing offered unless otherwise clearly stated in writing.

9.4 **Price reduction and adjustment:** Price reduction may be offered at any time during contract and shall become effective upon notice of acceptance from Region 10 ESC. Special, time-limited reductions are permissible under the following conditions: 1) reduction is available to all Members equally; 2) reduction is for a specific time period, normally not less than thirty (30) days; 3) original price is not exceeded after the time-limit; and 4) Region 10 ESC has approved the new prices prior to any offer of the prices to a Member. Vendor shall offer Region 10 ESC any published price reduction during the contract period.

9.5 **Prevailing Wage:** It shall be the responsibility of the Vendor to comply, when applicable, with the prevailing wage legislation in effect in the jurisdiction of the purchaser (Region 10 ESC or its Participating Members). It shall further be the responsibility of the Vendor to monitor the prevailing wage rates as established by the appropriate Department of Labor for any increase in rates during the term of this contract and adjust wage rates accordingly.

9.6 **Administrative Fees:** The Vendor agrees to pay administrative fees to Equalis Group based on the terms set in Attachment A. All pricing submitted to Region 10 ESC shall include the administrative fee to be remitted to Equalis Group by the awarded vendor.

9.7 **Price Calculation:** Cost plus a percentage as a primary mechanism to calculate pricing is not allowed. Pricing may either be in the form of line item pricing, defined as a specific individual price on a product or service, or a percentage discount from a verifiable catalog or price list. Other discounts or incentives may be offered.

ARTICLE 10- PRICING AUDIT

10.1 **Audit rights:** Vendor shall, at Vendor's sole expense, maintain appropriate due diligence of all purchases made by Region 10 ESC and any participating entity that accesses this Agreement. Equalis Group and Region 10 ESC each reserve the right to audit the accounting for a period of three (3) years from the time such purchases are made. This audit right shall survive termination of this Agreement for a period of one (1) year from the effective date of termination. In the State of New Jersey, this audit right shall survive termination of this Agreement for a period of five (5) years from the date of final payment. Such records shall be made available to the New Jersey Office of the State Comptroller upon request. Region 10 ESC shall have the authority to conduct random audits of Vendor's pricing that is offered to eligible entities at Region 10 ESC's sole cost and expense. Notwithstanding the foregoing, in the event that Region 10 ESC is made aware of any pricing being offered to eligible agencies that is materially inconsistent with the pricing under this agreement, Region 10 ESC shall have the ability to conduct an extensive audit of Vendor's pricing at Vendor's sole cost and expense. Region 10 ESC may conduct the audit internally or may engage a third-party auditing firm. In the event of an audit, the requested materials shall be provided in the format and at the location designated by Region 10 ESC or Equalis Group.

ARTICLE 11- PROPOSER PRODUCT LINE REQUIREMENTS

11.1 **Current products:** Proposals shall be for materials and equipment in current production and marketed to the general public and education/government agencies at the time the proposal is submitted.

11.2 **Discontinued products:** If a product or model is discontinued by the manufacturer, Vendor may substitute a new product or model if the replacement product meets or exceeds the specifications and performance of the discontinued model and if the discount is the same or greater than the discontinued model.

11.3 **New products/Services:** New products and/or services that meet the scope of work may be added to the contract. Pricing shall be equivalent to the percentage discount for other products. Vendor may replace or add product lines to an existing contract if the line is replacing or supplementing products on contract, is equal or superior to the original products offered, is discounted in a similar or to a greater degree, and if the products meet the requirements of the solicitation. No products and/or services may be added to avoid competitive procurement requirements. Region 10 ESC may require additions to be submitted with documentation from Participating Members demonstrating an interest in, or a potential requirement for, the new product or service. Region 10 ESC may reject any additions without cause.

11.4 **Options:** Optional equipment for products under contract may be added to the contract at the time they become available under the following conditions: 1) the option is priced at a discount similar to other options; 2) the option is an enhancement to the unit that improves performance or reliability.

11.5 **Product line:** Vendors with a published catalog may submit the entire catalog. Region 10 ESC reserves the right to select products within the catalog for award without having to award all contents. Region 10 ESC may reject any addition of equipment options without cause.

11.6 **Warranty conditions:** All supplies, equipment and services shall include manufacturer's minimum standard warranty and one (1) year labor warranty unless otherwise agreed to in writing.

11.7 **Buy American requirement:** (for New Jersey and all other applicable States) Vendors may only use unmanufactured construction material mined or produced in the United States, as required by the Buy American Act. Where trade agreements apply, to the extent permitted by applicable law, then unmanufactured construction material mined or produced in a designated country may also be used. Vendors are required to check state specific requirements to ensure compliance with this requirement.

ARTICLE 12- SITE REQUIREMENTS

12.1 **Cleanup:** Vendor shall clean up and remove all debris and rubbish resulting from their work as required or directed by Member. Upon completion of the work, the premises shall be left in good repair and an orderly, neat, clean and unobstructed condition conducive to the Member's business purpose.

12.2 **Site Preparation:** Vendor shall not begin a project for which Participating Member has not prepared the site, unless Vendor does the preparation work at no cost, or until Participating Member includes the cost of site preparation in a purchase order to the contractor. Site preparation includes, but is not limited to moving furniture, moving equipment or obstructions to the work area, installation of wiring for networks or any other necessary pre-installation requirements.

12.3 **Registered sex offender restrictions:** For work to be performed at schools, Vendor agrees that no employee or employee of a subcontractor who has been adjudicated to be a registered sex offender will perform work at any time when students are or are reasonably expected to be present. Vendor agrees that a violation of this condition shall be considered a material breach and may result in the cancellation of the purchase order at the Participating Member's discretion. Vendor must identify any additional costs associated with compliance of this term. If no costs are specified, compliance with this term will be provided at no additional charge. Vendor is also responsible for ensuring that their employees or contractors who have direct contact with students are properly fingerprinted and background checked in accordance with local state law, if applicable.

12.4 **Safety measures:** Vendor shall take all reasonable precautions for the safety of employees on the worksite, and shall erect and properly maintain all necessary safeguards for protection of workers and the public. Vendor shall post warning signs against all hazards created by its operation and work in progress. Proper precautions shall be taken pursuant to state law and standard practices to protect workers, general public and existing structures from injury or damage.

12.5 **Smoking/Tobacco:** Persons working under the contract shall adhere to local tobacco and smoking (including e-cigarettes/vaping) policies. Smoking will only be permitted in posted areas or off premises.

12.6 **Stored materials:** Upon prior written agreement between the vendor and Member, payment may be made for materials not incorporated in the work but delivered and suitably stored at the site or some other location, for installation at a later date. An inventory of the stored materials must be provided to Participating Member with the application for payment seeking compensation for stored materials. Such materials must be stored and protected in a secure location, and be insured for their full value by the vendor against loss and damage. Vendor agrees to provide proof of coverage and/or addition of Participating Member as an additional insured upon Participating Member's request. Additionally, if stored offsite, the materials must also be clearly identified as property of buying Participating Member and be separated from other materials. Participating Member must be allowed reasonable opportunity to inspect and take inventory of stored materials, on or offsite, as necessary.

Until final acceptance by the Participating Member, it shall be the Vendor's responsibility to protect all materials and equipment. Vendor warrants and guarantees that title for all work, materials and equipment shall pass to the Member upon final acceptance.

12.7 **Maintenance Facilities and Support**: It is preferred that each contractor should have maintenance facilities and a support system available for servicing and repair of product and/or equipment. If a third party is to be used to provide maintenance and support to the participating member, Respondent must notify Region 10 ESC of that third party information. All technicians, applicators, installers shall be fully certified, trained and licensed to perform said duties.

ARTICLE 13- MISCELENOUS

13.1 **Funding Out Clause**: Any/all contracts exceeding one (1) year shall include a standard "funding out" clause. A contract for the acquisition, including lease, of real or personal property is a commitment of the entity's current revenue only, provided the contract contains either or both of the following provisions:

"Retains to the entity the continuing right to terminate the contract at the expiration of each budget period during the term of the contract and is conditioned on a best efforts attempt by the entity to obtain appropriate funds for payment of the contract in the subsequent fiscal year."

13.2 **Disclosures**: Vendor affirms that he/she has not given, offered to give, nor intends to give at any time hereafter any economic opportunity, future employment, gift, loan, gratuity, special discount, trip, favor or service to a public servant in connection with this contract.

Vendor has a continuing duty to disclose a complete description of any and all relationships that might be considered a conflict of interest in doing business with participants in Equalis Group.

Vendor affirms that, to the best of his/her knowledge, the offer was arrived at independently, and was submitted without collusion with anyone to obtain information or gain any favoritism that would in any way limit competition or give an unfair advantage over other vendors in the award of this contract.

13.3 **Indemnity**: Vendor shall protect, indemnify, and hold harmless both Region 10 ESC and Equalis Group and its participants, administrators, employees and agents against all claims, damages, losses and expenses arising out of or resulting from the actions of Vendor, Vendor employees or Vendor subcontractors in the preparation of the solicitation and the later execution of the contract, including any supplemental agreements with members. Any litigation involving either Region 10 ESC or Equalis Group, its administrators and employees and agents shall be in a court of competent jurisdiction in Dallas County, Texas. Texas law shall apply to any such suit, without giving effect to its choice of laws provisions. Any litigation involving Equalis Group participating members shall be in the jurisdiction of the participating agency.

13.4 **Franchise Tax**: Vendor hereby certifies that he/she is not currently delinquent in the payment of any required franchise taxes, and shall remain current on any such franchise taxes throughout the term of this contract.

13.5 **Marketing**: Vendor agrees to allow Region 10 ESC and Equalis Group to use their name and logo within website, marketing materials and advertisement. Any use of the Region 10 ESC or Equalis Group name and logo

or any form of publicity, inclusive of press releases, regarding this contract by Vendor must have prior approval from Region 10 ESC.

13.6 **Insurance:** Unless otherwise modified elsewhere in this document, prior to commencing services under this contract for a participating member, contractor shall procure, provide and maintain during the life of this agreement comprehensive public liability insurance to include course of construction insurance and automobile liability, providing limits of not less than \$1,000,000.00 per occurrence. The insurance form will be an "all risk" type of policy with standard exclusions. Coverage will include temporary structures, scaffolding, temporary office trailers, materials, and equipment. Contractor shall pay for the deductibles required by the insurance provided under this agreement.

Certificates of insurance shall be delivered to the participant prior to commencement of work. The insurance company shall be licensed to do business and write the appropriate lines of insurance in the applicable state in which work is being conducted. Vendor shall give the participating entity a minimum of ten (10) days notice prior to any modifications or cancellation of policies. Vendor shall require all subcontractors performing any work to maintain coverage as specified.

Prior to commencing any work under this contract, any subcontractor shall also procure, provide, and maintain, at its own expense until final acceptance of the work performed, insurance coverage in a form acceptable to the prime contractor. All subcontractors shall provide worker's compensation insurance which waives all subrogation rights against the prime contractor and member.

13.7 **Subcontracts/Sub Contractors:** If Vendor serves as prime contractor, it shall not enter into any subcontract subject to this solicitation without prior approval from Region 10 ESC. Any/all subcontractors shall abide by the terms and conditions of this contract and the solicitation.

No subcontract relationships shall be entered into with a party not licensed to do business in the jurisdiction in which the work will be performed. Contractor must use subcontractors openly, include such arrangements in the proposal, and certify upon request that such use complies with the rules associated with the procurement codes and statutes in the state in which the contractor is conducting business.

Contractor agrees to pay subcontractors in a timely manner. Failure to pay subcontractors for work faithfully performed and properly invoiced may result in suspension or termination of this contract. Prior to participating member's release of final retained amounts, Contractor shall produce verified statements from all subcontractors and material suppliers that those entities have been paid in full amounts due and owing to them.

13.8 **Legal Obligations:** It is the Respondent's responsibility to be aware of and comply with all local, state, and federal laws governing the sale of products/services identified in this RFP and any awarded contract and shall comply with all while fulfilling the RFP. Applicable laws and regulation must be followed even if not specifically identified herein.

13.9 **Boycott Certification:** Respondents hereby certify that during the term of any Agreement, it does not boycott Israel and will not boycott Israel. "Boycott" means refusing to deal with, terminating business activities with, or otherwise taking any action that is intended to penalize, inflict economic harm on, or limit commercial relations specifically with Israel, or with a person or entity doing business in Israel or in an Israeli-controlled territory, but does not include an action made for ordinary business purposes.

13.10 **Venue:** All parties agree that venue for any litigation arising from this contract shall lie in Richardson, Dallas County, Texas, and that the laws of the State of Texas shall govern the rights of the parties and the validity

and interpretation of any purchase order, contract, or service agreement that shall arise from and include this proposal request.

[Remainder of Page Intentionally Left Blank- Signatures follow on Signature Form]

CONTRACT SIGNATURE FORM

The undersigned hereby proposes and agrees to furnish goods and/or services in strict compliance with the terms, specifications and conditions at the prices proposed within response unless noted in writing. The undersigned further certifies that he/she is an officer of the company and has authority to negotiate and bind the company named below and has not prepared this proposal in collusion with any other Respondent and that the contents of this proposal as to prices, terms or conditions of said proposal have not been communicated by the undersigned nor by any employee or agent to any person engaged in this type of business prior to the official opening of this proposal.

Prices are guaranteed: **120 days**

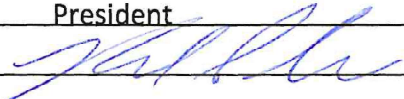
Company name Artcobell Corporation
Address 1302 Industrial Boulevard
City/State/Zip Temple, TX 76504
Telephone No. 877-778-1811
Fax No. _____
Email address rparker@artcobell.com
Printed name Rick Parker
Position with company President
Authorized signature 

Term of contract September 1, 2020 to August 31, 2023

Unless otherwise stated, all contracts are for a period of three (3) years with an option to renew annually for an additional four (4) years if agreed to by Region 10 ESC. Vendor shall honor all administrative fees for any sales made based on the contract whether renewed or not.

 10/5/20
Region 10 ESC Authorized Agent Date

Rickey Williams
Print Name

Equalis Group Contract Number EQ-052920-01B

DOC #1 CLEAN AIR AND WATER ACT

I, the Vendor, am in compliance with all applicable standards, orders or regulations issued pursuant to the Clean Air Act of 1970, as Amended (42 U.S. C. 1857 (h), Section 508 of the Clean Water Act, as amended (33 U.S.C. 1368), Executive Order 117389 and Environmental Protection Agency Regulation, 40 CFR Part 15 as required under OMB Circular A-102, Attachment O, Paragraph 14 (1) regarding reporting violations to the grantor agency and to the United States Environment Protection Agency Assistant Administrator for the Enforcement.

Potential Vendor: Artcobell Corporation

Title of Authorized Representative: Rick Parker, President

Mailing Address: 1302 Industrial Boulevard Temple, TX 76504

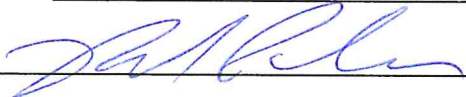
Signature: 

DOC #2 DEBARMENT NOTICE

I, the Vendor, certify that my company has not been debarred, suspended or otherwise ineligible for participation in Federal Assistance programs under Executive Order 12549, "Debarment and Suspension", as described in the Federal Register and Rules and Regulations.

Potential Vendor: Artcobell Corporation

Title of Authorized Representative: Rick Parker, President

Mailing Address: 1302 Industrial Boulevard Temple, TX 76504

Signature: 

DOC #3 LOBBYING CERTIFICATION

Submission of this certification is a prerequisite for making or entering into this transaction and is imposed by Section 1352, Title 31, U.S. Code. This certification is a material representation of fact upon which reliance was placed when this transaction was made or entered into. Any person who fails to file the required certification shall be subject to civil penalty of not less than \$10,000 and not more than \$100,000 for each such failure.

The undersigned certifies, to the best of his/her knowledge and belief, that:

1. No Federal appropriated funds have been paid or will be paid on behalf of the undersigned, to any person for influencing or attempting to influence an officer or employee of any agency, a Member of Congress, an officer or employee of Congress, or an employee of a Member of Congress in connection with the awarding of a Federal contract, the making of a Federal grant, the making of a Federal loan, the entering into a cooperative agreement, and the extension, continuation, renewal, amendment, or modification of a Federal contract, grant, loan, or cooperative agreement.
2. If any funds other than Federal appropriated funds have been or will be paid to any person for influencing or attempting to influence an officer or employee of any agency, a Member of Congress, an officer or employee of Congress, or an employee of a Member of Congress in connection with this Federal contract or cooperative agreement, the undersigned shall complete and submit Standard Form LLL, "Disclosure of Lobbying Activities," in accordance with its instructions.
3. The undersigned shall require that the language of this certification be included in the award documents for all covered sub-awards exceeding \$100,000 in Federal funds at all appropriate tiers and that all sub-recipients shall certify and disclose accordingly.

Rick Parker, President
Signature of Respondent

July 8, 2020
Date

DOC #4 CONTRACTOR CERTIFICATION REQUIREMENTS

Contractor’s Employment Eligibility

By entering the contract, Contractor warrants compliance with the Federal Immigration and Nationality Act (FINA), and all other federal and state immigration laws and regulations. The Contractor further warrants that it is in compliance with the various state statutes of the states it will operate this contract in.

Participating Government Entities including School Districts may request verification of compliance from any Contractor or subcontractor performing work under this Contract. These Entities reserve the right to confirm compliance in accordance with applicable laws.

Should the Participating Entities suspect or find that the Contractor or any of its subcontractors are not in compliance, they may pursue any and all remedies allowed by law, including, but not limited to: suspension of work, termination of the Contract for default, and suspension and/or debarment of the Contractor. All costs necessary to verify compliance are the responsibility of the Contractor.

The Respondent complies and maintains compliance with the appropriate statutes which requires compliance with federal immigration laws by State employers, State contractors and State subcontractors in accordance with the E-Verify Employee Eligibility Verification Program.

Contractor shall comply with governing board policy of the Region 10 ESC Participating entities in which work is being performed.

Fingerprint & Criminal Background Checks

If required to provide services on school district property at least five (5) times during a month, contractor shall submit a full set of fingerprints to the school district if requested of each person or employee who may provide such service. Alternately, the school district may fingerprint those persons or employees. An exception to this requirement may be made as authorized in Governing Board policy. The district shall conduct a fingerprint check in accordance with the appropriate state and federal laws of all contractors, subcontractors or vendors and their employees for which fingerprints are submitted to the district. Contractor, subcontractors, vendors and their employees shall not provide services on school district properties until authorized by the District.

The Respondent shall comply with fingerprinting requirements in accordance with appropriate statutes in the state in which the work is being performed unless otherwise exempted.

Contractor shall comply with governing board policy in the school district or Participating Entity in which work is being performed.

Business Operations in Sudan, Iran

In accordance with A.R.S. 35-391 and A.R.S. 35-393, the Contractor hereby certifies that the contractor does not have scrutinized business operations in Sudan and/or Iran.

 Rick Parker, President
Signature of Respondent

July 8, 2020
Date

**DOC #5 ANTITRUST CERTIFICATION STATEMENTS
(Tex. Government Code § 2155.005)**

I affirm under penalty of perjury of the laws of the State of Texas that:

- (1) I am duly authorized to execute this contract on my own behalf or on behalf of the company, corporation, firm, partnership or individual (Company) listed below;
- (2) In connection with this proposal, neither I nor any representative of the Company has violated any provision of the Texas Free Enterprise and Antitrust Act, Tex. Bus. & Comm. Code Chapter 15;
- (3) In connection with this proposal, neither I nor any representative of the Company has violated any federal antitrust law; and
- (4) Neither I nor any representative of the Company has directly or indirectly communicated any of the contents of this proposal to a competitor of the Company or any other company, corporation, firm, partnership or individual engaged in the same line of business as the Company.

VENDOR Artcobell Corporation

ADDRESS 1302 Industrial Boulevard

Temple, TX 76504

PHONE 877-778-1811

FAX _____

RESPONDANT



Signature

Rick Parker

Printed Name

President

Position with Company

AUTHORIZING OFFICIAL



Signature

Rick Parker

Printed Name

President

Position with Company

DOC #6 IMPLEMENTATION OF HOUSE BILL 1295

Certificate of Interested Parties (Form 1295):

In 2015, the Texas Legislature adopted House Bill 1295, which added section 2252.908 of the Government Code. The law states that a governmental entity or state agency may not enter into certain contracts with a business entity unless the business entity submits a disclosure of interested parties to the governmental entity or state agency at the time the business entity submits the signed contract to the governmental entity or state agency. The law applies only to a contract of a governmental entity or state agency that either (1) requires an action or vote by the governing body of the entity or agency before the contract may be signed or (2) has a value of at least \$1 million. The disclosure requirement applies to a contract entered into on or after January 1, 2016.

The Texas Ethics Commission was required to adopt rules necessary to implement that law, prescribe the disclosure of interested parties form, and post a copy of the form on the commission's website. The commission adopted the Certificate of Interested Parties form (Form 1295) on October 5, 2015. The commission also adopted new rules (Chapter 46) on November 30, 2015, to implement the law. The commission does not have any additional authority to enforce or interpret House Bill 1295.

Filing Process:

Starting on January 1, 2016, the commission will make available on its website a new filing application that must be used to file Form 1295. A business entity must use the application to enter the required information on Form 1295 and print a copy of the completed form, which will include a certification of filing that will contain a unique certification number. An authorized agent of the business entity must sign the printed copy of the form and have the form notarized. The completed Form 1295 with the certification of filing must be filed with the governmental body or state agency with which the business entity is entering into the contract.

The governmental entity or state agency must notify the commission, using the commission's filing application, of the receipt of the filed Form 1295 with the certification of filing not later than the 30th day after the date the contract binds all parties to the contract. The commission will post the completed Form 1295 to its website within seven business days after receiving notice from the governmental entity or state agency.

Information regarding how to use the filing application will be available on this site starting on January 1, 2016. https://www.ethics.state.tx.us/whatsnew/elf_info_form1295.htm

CERTIFICATE OF INTERESTED PARTIES

FORM 1295

1 of 1

Complete Nos. 1 - 4 and 6 if there are interested parties.
Complete Nos. 1, 2, 3, 5, and 6 if there are no interested parties.

OFFICE USE ONLY CERTIFICATION OF FILING

1 Name of business entity filing form, and the city, state and country of the business entity's place of business.

Artcobbell Corporation
Temple, TX United States

Certificate Number:
2020-639626

Date Filed:
07/02/2020

2 Name of governmental entity or state agency that is a party to the contract for which the form is being filed.

Region 10 ESC

Date Acknowledged:

3 Provide the identification number used by the governmental entity or state agency to track or identify the contract, and provide a description of the services, goods, or other property to be provided under the contract.

RFP: EQ-052920-01
Furniture & Storage

4	Name of Interested Party	City, State, Country (place of business)	Nature of interest (check applicable)	
			Controlling	Intermediary

5 Check only if there is NO Interested Party.

6 UNSWORN DECLARATION

My name is Rick Parker, and my date of birth is 8-2-1957.

My address is 1302 Industrial Blvd, Temple, TX, 76504, USA.
(street) (city) (state) (zip code) (country)

I declare under penalty of perjury that the foregoing is true and correct.

Executed in Bell County, State of Texas, on the 2 day of July, 2020.
(month) (year)



[Signature]
Signature of authorized agent of contracting business entity
(Declarant)

DOC #7 BOYCOTT CERTIFICATION

Respondents must certify that during the term of any Agreement, it does not boycott Israel and will not boycott Israel. "Boycott" means refusing to deal with, terminating business activities with, or otherwise taking any action that is intended to penalize, inflict economic harm on, or limit commercial relations specifically with Israel, or with a person or entity doing business in Israel or in an Israeli-controlled territory, but does not include an action made for ordinary business purposes.

During the term of the contract Artcobell does not boycott Israel and will not boycott Israel.

DOC #8 TERRORIST STATE CERTIFICATION

In accordance with Texas Government Code, Chapter 2252, Subchapter F, REGION 10 ESC is prohibited from entering into a contract with a company that is identified on a list prepared and maintained by the Texas Comptroller or the State Pension Review Board under Texas Government Code Sections 806.051, 807.051, or 2252.153. By execution of any agreement, the respondent certifies to REGION 10 ESC that it is not a listed company under any of those Texas Government Code provisions. Responders must voluntarily and knowingly acknowledge and agree that any agreement shall be null and void should facts arise leading the REGION 10 ESC to believe that the respondent was a listed company at the time of this procurement.

Artcobell certifies that it is not a listed company under any of those Texas Government Code provisions.

DOC #9 RESIDENT CERTIFICATION:

This Certification Section must be completed and submitted before a proposal can be awarded to your company. This information may be placed in an envelope labeled "Proprietary" and is not subject to public view. In order for a proposal to be considered, the following information must be provided. Failure to complete may result in rejection of the proposal:

As defined by Texas House Bill 602, a "nonresident Bidder" means a Bidder whose principal place of business is not in Texas, but excludes a contractor whose ultimate parent company or majority owner has its principal place of business in Texas.

Texas or Non-Texas Resident

- I certify that my company is a "resident Bidder"
- I certify that my company qualifies as a "nonresident Bidder"

If you qualify as a "nonresident Bidder," you must furnish the following information:

What is your resident state? (The state your principal place of business is located.)

pany Name _____ Address _____ Com _____

State _____ Zip _____ City _____

DOC #10 FEDERAL FUNDS CERTIFICATION FORM

When a participating agency seeks to procure goods and services using funds under a federal grant or contract, specific federal laws, regulations, and requirements may apply in addition to those under state law. This includes, but is not limited to, the procurement standards of the Uniform Administrative Requirements, Cost Principles and Audit Requirements for Federal Awards, 2 CFR 200 (sometimes referred to as the "Uniform Guidance" or "EDGAR" requirements). All Vendors submitting proposals must complete this Federal Funds Certification Form regarding Vendor's willingness and ability to comply with certain requirements which may be applicable to specific participating agency purchases using federal grant funds. This completed form will be made available to participating agencies for their use while considering their purchasing options when using federal grant funds. Participating agencies may also require Vendors to enter into ancillary agreements, in addition to the contract's general terms and conditions, to address the member's specific contractual needs, including contract requirements for a procurement using federal grants or contracts.

For each of the items below, Vendor should certify Vendor's agreement and ability to comply, where applicable, by having Vendor's authorized representative complete and initial the applicable lines after each section and sign the acknowledgment at the end of this form. If a vendor fails to complete any item in this form, Region 10 ESC will consider the Vendor's response to be that they are unable or unwilling to comply. A negative response to any of the items may, if applicable, impact the ability of a participating agency to purchase from the Vendor using federal funds.

1. Vendor Violation or Breach of Contract Terms:

Contracts for more than the simplified acquisition threshold currently set at \$150,000, which is the inflation adjusted amount determined by the Civilian Agency Acquisition Council and the Defense Acquisition Regulations Council (Councils) as authorized by 41 USC 1908, must address administrative, contractual, or legal remedies in instances where contractors violate or breach contract terms, and provide for such sanctions and penalties as appropriate.

Any Contract award will be subject to Region 10 ESC General Terms and Conditions, as well as any additional terms and conditions in any Purchase Order, participating agency ancillary contract, or Member Construction Contract agreed upon by Vendor and the participating agency which must be consistent with and protect the participating agency at least to the same extent as the Region 10 ESC Terms and Conditions.

The remedies under the Contract are in addition to any other remedies that may be available under law or in equity. By submitting a Proposal, you agree to these Vendor violation and breach of contract terms.

Does vendor agree? 
(Initials of Authorized Representative)

2. Termination for Cause or Convenience:

When a participating agency expends federal funds, the participating agency reserves the right to immediately terminate any agreement in excess of \$10,000 resulting from this procurement process in the event of a breach or default of the agreement by Offeror in the event Offeror fails to: (1) meet schedules, deadlines, and/or delivery dates within the time specified in the procurement solicitation, contract, and/or a purchase order; (2) make any payments owed; or (3) otherwise perform in accordance with the contract and/or the procurement solicitation. participating agency also reserves the right to terminate the contract immediately, with written notice to offeror, for convenience, if participating agency believes, in its sole discretion that it is in the best interest of participating agency to do so. Offeror will be compensated for work performed and accepted and goods accepted by participating agency as of the termination date if the contract is terminated for convenience of participating agency. Any award under this procurement process is not exclusive and participating agency reserves the right to purchase goods and services from other offerors when it is in participating agency's best interest.

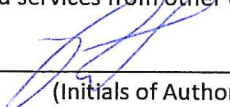
Does vendor agree? 
(Initials of Authorized Representative)

3. Equal Employment Opportunity:

Except as otherwise provided under 41 CFR Part 60, all participating agency purchases or contracts that meet the definition of "federally assisted construction contract" in 41 CFR Part 60-1.3 shall be deemed to include the equal opportunity clause provided under 41 CFR 60-1.4(b), in accordance with Executive Order 11246, "Equal Employment Opportunity" (30 FR 12319, 12935, 3 CFR Part, 1964-1965 Comp., p. 339), as amended by Executive Order 11375, "Amending Executive Order 11246 Relating to Equal Employment Opportunity," and implementing regulations at 41 CFR Part 60, "Office of Federal Contract Compliance Programs, Equal Employment Opportunity, Department of Labor."

The equal opportunity clause provided under 41 CFR 60-1.4(b) is hereby incorporated by reference. Vendor agrees that such provision applies to any participating agency purchase or contract that meets the definition of "federally assisted construction contract" in 41 CFR Part 60-1.3 and Vendor agrees that it shall comply with such provision.

Does vendor agree? 
(Initials of Authorized Representative)

4. Davis-Bacon Act:

When required by Federal program legislation, Vendor agrees that, for all participating agency prime construction contracts/purchases in excess of \$2,000, Vendor shall comply with the Davis-Bacon Act (40 USC 3141-3144, and 3146-3148) as supplemented by Department of Labor regulations (29 CFR Part 5, "Labor Standards Provisions Applicable to Contracts Covering Federally Financed and Assisted Construction"). In accordance with the statute, Vendor is required to pay wages to laborers and mechanics at a rate not less than the prevailing wages specified in a wage determinate made by the Secretary of Labor. In addition, Vendor shall pay wages not less than once a week.

Current prevailing wage determinations issued by the Department of Labor are available at www.wdol.gov. Vendor agrees that, for any purchase to which this requirement applies, the award of the purchase to the Vendor is conditioned upon Vendor's acceptance of the wage determination.

Vendor further agrees that it shall also comply with the Copeland "Anti-Kickback" Act (40 USC 3145), as supplemented by Department of Labor regulations (29 CFR Part 3, "Contractors and Subcontractors on Public Building or Public Work Financed in Whole or in Part by Loans or Grants from the United States"). The Act provides that each contractor or subrecipient must be prohibited from inducing, by any means, any person employed in the construction, completion, or repair of public work, to give up any part of the compensation to which he or she is otherwise entitled.

Does vendor agree? 
(Initials of Authorized Representative)

5. Contract Work Hours and Safety Standards Act:

Where applicable, for all participating agency contracts or purchases in excess of \$100,000 that involve the employment of mechanics or laborers, Vendor agrees to comply with 40 USC 3702 and 3704, as supplemented by Department of Labor regulations (29 CFR Part 5). Under 40 USC 3702 of the Act, Vendor is required to compute the wages of every mechanic and laborer on the basis of a standard work week of 40 hours. Work in excess of the standard work week is permissible provided that the worker is compensated at a rate of not less than one and a half times the basic rate of pay for all hours worked in excess of 40 hours in the work week. The requirements of 40 USC 3704 are applicable to construction work and provide that no laborer or mechanic must be required to work in surroundings or under working conditions which are unsanitary, hazardous or dangerous. These requirements do not apply to the purchases of supplies or materials or articles ordinarily available on the open market, or contracts for transportation or transmission of intelligence.

Does vendor agree? 
(Initials of Authorized Representative)

6. Right to Inventions Made Under a Contract or Agreement:

If the participating agency's Federal award meets the definition of "funding agreement" under 37 CFR 401.2(a) and the recipient or subrecipient wishes to enter into a contract with a small business firm or nonprofit organization regarding the substitution of parties, assignment or performance or experimental, developmental, or research work under that "funding agreement," the recipient or subrecipient must comply with the requirements of 37 CFR Part 401, "Rights to Inventions Made by Nonprofit Organizations and Small Business Firms Under Government Grants, Contracts and Cooperative Agreements," and any implementing regulations issued by the awarding agency.

Vendor agrees to comply with the above requirements when applicable.

Does vendor agree? 
(Initials of Authorized Representative)

7. Clean Air Act and Federal Water Pollution Control Act:

Clean Air Act (42 USC 7401-7671q.) and the Federal Water Pollution Control Act (33 USC 1251-1387), as amended –Contracts and subgrants of amounts in excess of \$150,000 must contain a provision that requires the non-Federal award to agree to comply with all applicable standards, orders, or regulations issued pursuant to the Clean Air Act (42 USC 7401-7671q.) and the Federal Water Pollution Control Act, as amended (33 USC 1251-1387). Violations must be reported to the Federal awarding agency and the Regional Office of the Environmental Protection Agency (EPA).

When required, Vendor agrees to comply with all applicable standards, orders, or regulations issued pursuant to the Clean Air Act and the Federal Water Pollution Control Act.

Does vendor agree? 
(Initials of Authorized Representative)

8. Debarment and Suspension:

Debarment and Suspension (Executive Orders 12549 and 12689) – A contract award (see 2 CFR 180.220) must not be made to parties listed on the government-wide exclusions in the System for Award Management (SAM), in accordance with the OMB guidelines at 2 CFR 180 that implement Executive Orders 12549 (3 CFR Part 1966 Comp. p. 189) and 12689 (3 CFR Part 1989 Comp. p. 235), "Debarment and Suspension." SAM Exclusions contains the names of parties debarred, suspended, or otherwise excluded by agencies, as well as parties declared ineligible under statutory or regulatory authority other than Executive Order 12549.

Vendor certifies that Vendor is not currently listed on the government-wide exclusions in SAM, is not debarred, suspended, or otherwise excluded by agencies or declared ineligible under statutory or regulatory authority other than Executive Order 12549. Vendor further agrees to immediately notify the Cooperative and all participating agencies with pending purchases or seeking to purchase from Vendor if Vendor is later listed on the government-wide exclusions in SAM, or is debarred, suspended, or otherwise excluded by agencies or declared ineligible under statutory or regulatory authority other than Executive Order 12549.

Does vendor agree? 
(Initials of Authorized Representative)

9. Byrd Anti-Lobbying Amendment:

Byrd Anti-Lobbying Amendment (31 USC 1352) -- Vendors that apply or bid for an award exceeding \$100,000 must file the required certification. Each tier certifies to the tier above that it will not and has not used Federal appropriated funds to pay any person or organization for influencing or attempting to influence an officer or employee of any agency, a member of Congress, officer or employee of Congress, or an employee of a member of Congress in connection with obtaining any Federal contract, grant or any other award covered by 31 USC 1352. Each tier must also disclose any lobbying with non-Federal funds that takes place in connection with obtaining any Federal award. Such disclosures are forwarded from tier to tier up to the non-Federal award. As applicable, Vendor agrees to file all certifications and disclosures required by, and otherwise comply with, the Byrd Anti-Lobbying Amendment (31 USC 1352).

Does vendor agree? 
(Initials of Authorized Representative)

10. Procurement of Recovered Materials:

For participating agency purchases utilizing Federal funds, Vendor agrees to comply with Section 6002 of the Solid Waste Disposal Act, as amended by the Resource Conservation and Recovery Act where applicable and provide such information and certifications as a participating agency may require to confirm estimates and otherwise comply. The requirements of Section 6002 include procuring only items designated in guidelines of the Environmental Protection Agency (EPA) at 40 CFR Part 247 that contain the highest percentage of recovered materials practicable, consistent with maintaining a satisfactory

level of competition, where the purchase price of the item exceeds \$10,000 or the value of the quantity acquired during the preceding fiscal year exceeded \$10,000; procuring solid waste management services in a manner that maximizes energy and resource recovery, and establishing an affirmative procurement program for procurement of recovered materials identified in the EPA guidelines.

Does vendor agree? RP
(Initials of Authorized Representative)

11. Profit as a Separate Element of Price:

For purchases using federal funds in excess of \$150,000, a participating agency may be required to negotiate profit as a separate element of the price. See, 2 CFR 200.323(b). When required by a participating agency, Vendor agrees to provide information and negotiate with the participating agency regarding profit as a separate element of the price for a particular purchase. However, Vendor agrees that the total price, including profit, charged by Vendor to the participating agency shall not exceed the awarded pricing, including any applicable discount, under Vendor's Cooperative Contract.

Does vendor agree? RP
(Initials of Authorized Representative)

12. General Compliance and Cooperation with Participating Agencies:

In addition to the foregoing specific requirements, Vendor agrees, in accepting any Purchase Order from a participating agency, it shall make a good faith effort to work with participating agencies to provide such information and to satisfy such requirements as may apply to a particular participating agency purchase or purchases including, but not limited to, applicable recordkeeping and record retention requirements.

Does vendor agree? RP
(Initials of Authorized Representative)

13. Applicability to Subcontractors

Offeror agrees that all contracts it awards pursuant to the Contract shall be bound by the foregoing terms and conditions.

Does vendor agree? RP
(Initials of Authorized Representative)

By signature below, I certify that the information in this form is true, complete, and accurate and that I am authorized by my company to make this certification and all consents and agreements contained herein.

Artcobell Corporation
Company Name
RP
Signature of Authorized Company Official

Rick Parker
Printed Name

President
Title

July 8, 2020
Date

DOC #11 ADDITIONAL ARIZONA CONTRACTOR REQUIREMENTS

AZ Compliance with Federal and state requirements: Contractor agrees when working on any federally assisted projects with more than \$2,000.00 in labor costs, to comply with all federal and state requirements, as well as Equal Opportunity Employment requirements and all other federal and state laws, statutes, etc. Contractor agrees to post wage rates at the work site and submit a copy of their payroll to the member for their files. Contractor must retain records for three years to allow the federal grantor agency access to these records, upon demand. Contractor also agrees to comply with the Arizona Executive Order 75-5, as amended by Executive Order 99-4.

When working on contracts funded with Federal Grant monies, contractor additionally agrees to comply with the administrative requirements for grants, and cooperative agreements to state, local and federally recognized Indian Tribal Governments.

AZ Compliance with workforce requirements: Pursuant to ARS 41-4401, Contractor and subcontractor(s) warrant their compliance with all federal and state immigration laws and regulations that relate to their employees, and compliance with ARS 23-214 subsection A, which states, ..."every employer, after hiring an employee, shall verify the employment eligibility of the employee through the E-Verify program" Region 10 ESC reserves the right to cancel or suspend the use of any contract for violations of immigration laws and regulations. Region 10 ESC and its members reserve the right to inspect the papers of any contractor or subcontract employee who works under this contract to ensure compliance with the warranty above.

AZ Contractor Employee Work Eligibility: By entering into this contract, contractor agrees and warrants compliance with A.R.S. 41-4401, A.R.S. 23-214, the Federal Immigration and Nationality Act (FINA), and all other Federal immigration laws and regulations. Region 10 ESC and/or Region 10 ESC members may request verification of compliance from any contractor or sub contractor performing work under this contract. Region 10 ESC and Region 10 ESC members reserve the right to confirm compliance. In the event that Region 10 ESC or Region 10 ESC members suspect or find that any contractor or subcontractor is not in compliance, Region 10 ESC may pursue any and all remedies allowed by law, including but not limited to suspension of work, termination of contract, suspension and/or debarment of the contractor. All cost associated with any legal action will be the responsibility of the contractor.

AZ Non-Compliance: All federally assisted contracts to members that exceed \$10,000.00 may be terminated by the federal grantee for noncompliance by contractor. In projects that are not federally funded, Respondent must agree to meet any federal, state or local requirements as necessary. In addition, if compliance with the federal regulations increases the contract costs beyond the agreed on costs in this solicitation, the additional costs may only apply to the portion of the work paid by the federal grantee.

Registered Sex Offender Restrictions (Arizona): For work to be performed at an Arizona school, contractor agrees that no employee or employee of a subcontractor who has been adjudicated to be a registered sex offender will perform work at any time when students are present, or reasonably expected to be present. Contractor agrees that a violation of this condition shall be considered a material breach and may result in the cancellation of the purchase order at the Region 10 ESC member's discretion. Contractor must identify any additional costs associated with compliance to this term. If no costs are specified, compliance with this term will be provided at no additional charge.

Offshore Performance of Work Prohibited: Due to security and identity protection concerns, direct services under this contract shall be performed within the borders of the United States.

Terrorism Country Divestments: In accordance with A.R.S. 35-392, Region 10 ESC and Region 10 ESC members are prohibited from purchasing from a company that is in violation of the Export Administration Act. By entering into the contract, contractor warrants compliance with the Export Administration Act.

The undersigned hereby accepts and agrees to comply with all statutory compliance and notice requirements listed in this document.

Signature of Respondent

Rick Parker, President

June 8, 2020

Date



FOR VENDORS INTENDING TO DO BUSINESS IN NEW JERSEY:

- DOC #12 Ownership Disclosure Form
- DOC #13 Non-Collusion Affidavit
- DOC #14 Affirmative Action Affidavit
- DOC #15 Political Contribution Disclosure Form
- DOC #16 Stockholder Disclosure Form

The Artcobell Corporation does not plan to use this contract in the State of New Jersey.

The forms listed above will not be provided with the contract documents.

DOC #17 GENERAL TERMS & CONDITIONS ACCEPTANCE FORM

Signature on the Vendor Contract Signature form certifies complete acceptance of the General Terms and Conditions in this solicitation, except as noted below (additional pages may be attached, if necessary).

Check one of the following responses to the General Terms and Conditions:

We take no exceptions/deviations to the general terms and conditions

(Note: If none are listed below, it is understood that no exceptions/deviations are taken.)

We take the following exceptions/deviations to the general terms and conditions. All exceptions/deviations must be clearly explained. Reference the corresponding general terms and conditions that you are taking exceptions/deviations to. Clearly state if you are adding additions terms and conditions to the general terms and conditions. Provide details on your exceptions/deviations below:

(Note: Unacceptable exceptions shall remove your proposal from consideration for award. Region 10 ESC shall be the sole judge on the acceptance of exceptions/deviations and the decision shall be final.)

See attached document for exceptions.

Section/Page	Term, Condition, or Specification	Exception/Proposed Modification	Accepted (For Region 10 ESC's
<p>Article 4 - Formation of Contract</p> <p>4.4 Assignment of Contract</p> <p>Page 23</p>	<p>4.4. Assignment of Contract: No assignment of contract may be made without the prior written approval of Region 10 ESC. Purchase orders and payment can only be made to awarded vendor unless otherwise approved by Region 10 ESC. Awarded vendor is required to notify Region 10 ESC when any material change in operations is made that may adversely affect members (i.e. awarded vendor bankruptcy, merger, etc.).</p>	<p>4.4. Assignment of Contract: No assignment of contract may be made without the prior written approval of Region 10 ESC. Purchase orders and payment can only be made to awarded vendor unless otherwise approved by Region 10 ESC. only be made to awarded vendor unless otherwise approved by Region 10 ESC. be made to the vendor's/Artcoell's authorized dealer. Awarded vendor is required to notify Region 10 ESC when any material change in operations is made that may adversely affect members (i.e. awarded vendor bankruptcy, change of ownership, merger, etc.).</p> <p>Explanation: The Artcobell Corporation is bidding this contract direct but will operate thru authorized dealers. Authorized dealers can accept purchase orders, invoice purchase orders, and invoice public agencies directly. Artcobell is responsible for remitting sales reports and administrative fee payments to Equalis Group. A list of authorized dealers is provided with the contract documents.</p>	

Section/Page	Term, Condition, or Specification	Exception/Proposed Modification	Accepted (For Region 10 ESC's)
<p>Article 7 - Delivery Provisions</p> <p>7.1 Delivery Page 26</p>	<p>7.1 Delivery: Vendor shall deliver said materials purchased on this contract to the participating member issuing a Purchase Order. Conforming product shall be shipped within 7 days of receipt of Purchase Order. If delivery is not or cannot be made within this time period the vendor must receive authorization from the purchasing agency for the delayed delivery. At this point the participating entity may cancel the order if estimated shipping time is not acceptable.</p>	<p>7.1 Delivery: Vendor shall deliver said materials purchased on this contract to the participating member issuing a Purchase Order. Conforming product shall be shipped within 7 days of receipt of Purchase Order. the timeframe mutually agreed to by the vendor and the purchasing agency. If delivery is not or cannot be made within this time period the vendor must receive authorization from the purchasing agency for the delayed delivery. At this point the participating entity may cancel the order if estimated shipping time is not acceptable.</p> <p>Explanation for Exception/Deviation: Our furniture is made-to-order, typical acknowledgement ready time frames are within standard published lead times after receipt of order. We will work with the Region 10 customer to determine an acceptable delivery schedule.</p>	

Section/Page	Term, Condition, or Specification	Exception/Proposed Modification	Accepted (For Region 10 ESC's)
<p>Article 8 - Billing and Reporting</p> <p>8.1 Payments</p> <p>Page 27</p>	<p>8.1 Payments: The participating entity using the contract will make payments directly to the awarded vendor. Payment shall be made after satisfactory performance, in accordance with all provisions thereof, and upon receipt of a properly completed invoice.</p>	<p>8.1 Payments: The participating entity using the contract will make payments directly to the awarded vendor; vendor's/Artcobell's authorized dealer. Payment shall be made after satisfactory performance, in accordance with all provisions thereof, and upon receipt of a properly completed invoice.</p> <p>Explanation: The Artcobell Corporation is bidding this contract direct but will operate thru authorized dealers. Authorized dealers can accept purchase orders, invoice purchase orders, and invoice public agencies directly. Artcobell is responsible for remitting sales reports and administrative fee payments to Equalis Group. A list of authorized dealers is provided with the contract documents.</p>	

Section/Page	Term, Condition, or Specification	Exception/Proposed Modification	Accepted (For Region 10 ESC's)
<p>Article 12 - Site Requirements</p> <p>12.6 Stored materials</p> <p>Page 30 & 31</p>	<p>12.6 Stored materials: Upon prior written agreement between the vendor and Member, payment may be made for materials not incorporated in the work but delivered and suitably stored at the site or some other location, for installation at a later date. An inventory of the stored materials must be provided to Participating Member with the application for payment seeking compensation for stored materials. Such materials must be stored and protected in a secure location, and be insured for their full value by the vendor against loss and damage. Vendor agrees to provide proof of coverage and/or addition of Participating Member as an additional insured upon Participating Member's request. Additionally, if stored offsite, the materials must also be clearly identified as property of buying Participating Member and be separated from other materials. Participating Member must be allowed reasonable opportunity to inspect and take inventory of stored materials, on or offsite, as necessary.</p> <p>Until final acceptance by the Participating Member, it shall be the Vendor's responsibility to protect all materials and equipment. Vendor warrants and guarantees that title for all work, materials and equipment shall pass to the Member upon Member acceptance of non-defective undamaged, product at time of delivery.</p> <p>Explanation for Exception/Deviation: This section contemplates the end user taking possession and control of the furniture, so their insurance should automatically cover any losses to the product. Once the product is outside of the Vendor's control, the Vendor has no ability to protect the product from loss. We would assume all risk of loss that occurs during or prior to shipment of the product or damage occurring during installation.</p>	<p>12.6 Stored materials: Upon prior written agreement between the vendor and Member, payment may be made for materials not incorporated in the work but delivered and suitably stored at the site or some other location, for installation at a later date. An inventory of the stored materials must be provided to Participating Member with the application for payment seeking compensation for stored materials. Such materials must be stored and protected in a secure location, and be insured for their full value by the vendor party in control of the location against loss and damage unless otherwise agreed to by Member and Vendor. The insuring party Vendor agrees to provide proof of coverage and/or addition of Participating Member as an additional insured upon Participating Member's request. Additionally, if stored offsite, the materials must also be clearly identified as property of buying Participating Member and be separated from other materials. Participating Member must be allowed reasonable opportunity to inspect and take inventory of stored materials, on or offsite, as necessary.</p> <p>Until final acceptance by the Participating Member, it shall be the Vendor's responsibility to protect all materials and equipment. Vendor warrants and guarantees that title for all work, materials and equipment shall pass to the Member upon Member acceptance of non-defective undamaged, product at time of delivery.</p> <p>Explanation for Exception/Deviation: This section contemplates the end user taking possession and control of the furniture, so their insurance should automatically cover any losses to the product. Once the product is outside of the Vendor's control, the Vendor has no ability to protect the product from loss. We would assume all risk of loss that occurs during or prior to shipment of the product or damage occurring during installation.</p>	

ATTACHMENT A: Requirements for Lead Agency Agreement To be administered by Equalis Group

The following exhibits are used in evaluating and administering Lead Agency Agreements and are preferred by Equalis Group. Redlined copies of the exhibits should not be submitted with the response. Should a respondent be recommended for award, these exhibits will be negotiated and executed between Equalis Group and the respondent. **Respondents must select one of the following options for submitting their response and submit this page only.**

- Respondent agrees to all terms and conditions outlined in each of the following exhibits
- Respondent wishes to negotiate directly with Equalis Group on terms and conditions outlined in each of the following exhibits. Negotiations will commence after sealed bids are opened and Region 10 has determined the respondent met all requirements in their response and may be eligible for award.

- Equalis Group Exhibit A – EQUALIS GROUP RESPONSE FOR LEAD AGENCY AGREEMENT
- Equalis Group Exhibit B – EQUALIS GROUP ADMINISTRATION AGREEMENT
- Equalis Group Exhibit C – EQUALIS GROUP MASTER INTERGOVERNMENTAL COOPERATIVE PURCHASING AGREEMENT
- Equalis Group Exhibit D – EQUALIS GROUP CONTRACT SALES REPORTING TEMPLATE Equalis Group



Product/Services/Pricing

Category:

Artcobell is proposing our complete catalog offering.

Artcobell maintains competitive prices and does not set inflated list prices on products. We have one of the largest breadths and depth of product to serve progressive, current and traditional learning environments; we feel when comparing net pricing to the competition our pricing is very competitive at all buying levels.

Any services not indicated on the discount from manufacturer's list price page, will need to be coordinated and costed with the Artcobell authorized dealer.

Authorized Dealers:

The Artcobell Corporation is bidding this contract direct but will operate thru authorized dealers. Authorized dealers can accept purchase orders, invoice purchase orders, and invoice public agencies directly. Artcobell is responsible for remitting sales reports and administrative fee payments to the Equalis Group.

A list of authorized dealers is attached.

Product/Price Updates:

Artcobell is continuously developing new products to enhance our offering. We will ensure to advise Region 10 of new product releases as well as all obsolete and discontinued products in writing and in a timely manner. Artcobell has included the 2020 Price List. Artcobell does a yearly price increase, which will be provided to Region 10 once completed and in a timely manner. The discount from manufacturer's price list is taken from the price list that is in effect at the time the order is placed.

Returns:

Due to the number of options, such as fabrics, finishes, etc. our products are made-to order and therefore not typically stocked. With the custom nature of our product, it is not a viable option for us to sell the returned product to another customer; therefore, the restocking fee will be 25% of the value of the item.

Product will not be returned for refund, credit or replacement, except on written approval by Artcobell. Returned product is subject to a restocking fee and any associated freight charges. No restocking fee may be charged if an item is returned due to the incorrect product shipped or vendor order entry error.



DEALER LIST

Name	Address	Zip Code	City	State	Contact	Phone	Email
360 Office Solutions	P O Box 30598	59107	Billings	MT	Frank Cross	406-248-7881	frankc@360-os.com
A.R. Kropp Co & Sons	1515-B Fifth Industrial Court	11706	Bay Shore	NY	Timothy Kroop	631-549-9240	timothykropp@arkshelving.com
AAA Business Supplies	325 Mendell St.	94124	San Francisco	CA	Chuck Bonham	415-655-7069	chuckb@aaasolutions.com
AK Sales & Consulting	1202 E 19th Street	88201	Roswell	NM	Angelica Buckmister	575-623-1488	aksalesnm@gmail.com
Alaska Educational and	Recreational Product LLC	99503	Anchorage	AK	Kit Wilson	907-229-1655	kitw@akedproducts.com
All Makes Office Equip	2558 Farnam Street	68131	Omaha	NE	Mike Miten	402 977 3030	mikem@allmakes.com
American Design Associates	9000 Harford Road	21234	Parkville	MD	Theresa Alcarese	401-823-5500	theresa@americandesignonline.com
Arizona Furnishings	6913 W Buckeye Rd	85043	Phoenix	AZ	Claudia Spillman	602 484 7331	claudia@furnishaz.com
Business Interiors of Idaho	176 S Capitol Blvd	83702	Boise	ID	Neil Harris	808-322-3634	neil@biimail.com
Campbell Keller	P.O. Box 277788	95827-7788	Sacramento	CA	Craig Campbell	916-231-9236	ccampbell@campbellkeller.com
Catalyst Workplace	1707 Dock Street	98402	Tacoma	WA	Eden Magnusson	253-389-3883	emagnusson@catalystactivation.com
Commercial Stationery Co	723 Scooba Street	39401	Hattiesburg	MS	Wayne Ross	601-543-2196	comstat13@hotmail.com
CORE Business Interiors	7761 N Ingram	93711	Fresno	CA	Sarah Mitchell	559-297-6400	sarahd@corebusinessinteriors.com
Dixie Equip Co, Inc	P O Box 565	27298	Liberty	NC	Kevin Cooney	336 622 4202	kevin@dixieequipmentco.com
Educational Furniture LTD	620 East 18th Street	47302	Muncie	IN	Matt Simmons	765 286 9041	matt@edfurn.com
Educational Interiors, Inc	P.O. Box 2257	39043	Brandon	MS	Cris Vinson	601-953-8127	Cris Vinson cvinson@edinteriors.com
Edutek Corporation	4060 South 500 West #4	84123	Salt Lake City	UT	Peter Vanderhooft	801 747 0050	pvanderhooft@edutekcorp.com
Ernie Morris Enterprises	PO Box 818	33513	Bushnell	FL	Adin Burchfield	404 822 6958	aburchfield@erniemorris.com
FM Office Express	106 Despatch Dr, Suite 2	14445	East Rochester	NY	Ann Miller-Michaels	585-238-2827	amiller-michaels@merkel.com
Frank Cooney Company	1226 N. Michael Dr. Suite C	60191	Wood Dale	IL	Greg Cooney	630 694 8800	gregory@frankcooney.com
Furniture Plus Design	700 Bishop Street Suite 108	96813	Honolulu	HI	Scott Barley	808-398-7322	scott@furnitureplushawaii.com
Furniture Specialist, Inc.	Wylie's Disc Sch & Of Fur	38732	Cleveland	MS	Blake Hilburn	662-843-5295	blakehilburn@aol.com
General Office Products	4521 Highway 7	55416	Minneapolis	MN	Kate Reckinger	952-925-7505	kreckinger@gopoco.com
Grand River Office	99 W. Western Ave	49442	Muskegon	MI	Doug Brown	833-477-4837	dbrown@grandriveroffice.com
Health & Educational Equip	1371 Church Street, Suite 5	11716	Bohemia	NY	Jim Myers	631 563 6500	jim@hneequipment.com
Holland Heritage Furniture	PO Box 771	39555	Hurley	MS	LENN WALL	228-219-2505	lennwall@hollandheritagefurniture.com
Illini Supply	111 Illini Drive	62535	Forsyth	IL	Deborah Born	217-877-6551	deborah.born@illinisupply.com
Indeco Sales, Inc.	805 E 4th Street	76513	Belton	TX	Kevin Goldston	254 939 5742	kevin.goldston@indecosales.com
Innovative Office Solutions	151 East Cliff Road STE 40	55337	Burnsville	MN	Brian Howell	952 808 9900	bhowell@innovativeos.com
Interior Environment, LLC	48700 Grand River Ave	48374	Novi	MI	Rick George	248-996-6234	regoerge@ieoffices.com
Interior Systems Inc	PO Box 529	27376	West End	NC	Mark Goudy	910 673 0633	mgoudy.isi@wildblue.net
Interiors by Guernsey	4425 Brookfield Corp Dr	20151	Chantilly	VA	Phil Allin	703-788-3398	phil@interiorsbyguernsey.com
Interphase Office Interiors	3036 Eastern Ave SE	49508	Grand Rapids	MI	Keely Eagle Trombly	231-941-4454	kelly@interphaseinc.com

L&M Office Furniure	4444 S 91st East Avenue	74145	Tulsa	OK	Jim Stewart	918-664-1010	jims@l-mofficefurn.com
Lee Distributors Inc	PO Box 447	07462	Vernon	NJ	Jim Lancelotti	973 764 9191	leedist@warwick.net
Midwest Educational Furnish	21191 N Valley Rd	60047	Lake Zurich	IL	Dave Welter	847-847-7519	dwelter@mwfurnishings.com
Moser Corporation	P O Box 1984	72757	Rogers	AR	Phil Moser	479 636 3481	pmoser58@yahoo.com
Nickerson Corporation	PO Box 5751	11706	Bay Shore	NY	Mike Walsh	631-666-0200 x223	mwalsh@nickersoncorp.com
Office & Ergonomic Solutions	8480 Utica Ave	91730	Rancho Cucamonga	CA	Penny Vergara	909-527-4643 x101	penny@oesofficefurniture.com
Office Basics Inc.	22 Creek Circle	19061	Marcus Hook	PA	Mike Rowles	610-471-1000	mrowles@officebasics.com
Office Environment Co - ID	623 S Americana Blvd	83702-6732	Boise	ID	Rachael Ross	208-385-0507 x111	rross@oecboise.com
OfficeScapes	2506 Zeppelin Road	80916	Colorado Springs	CO	Lee Stapp	719 574 1113	lstapp@officescapes.com
OneWork Place	2500 De La Cruz Blvd.	95050	Santa Clara	CA	Brandon Thomas	415-357-2261	bthomas@oneworkplace.com
Palace Office Interiors	2606 Chanticleer Ave	95065	Santa Cruz	CA	Terri Cowgill	831 646 2034	orders@gopalace.com
Paragon Commercial Interiors	210 Emerson Place STE 300	52801-1633	Davenport	IA	Lauren Stottler	563-326-1611	laurens@paragoninteriors.com
Premier Furniture & Equip	PO Box 223	50677	Waverly	IA	Roger Johnson	319-559-8832	saras@fepremier.com
Red Thread Spaces LLC	101 Seaport Boulevard #600	02210	Boston	MA	Mary Sauvageau	860-291-5780	msauvageau@red-thread.com
RPA, Inc	PO Box 127	35201	Birmingham	AL	Tim Shugart	205 324 5641	tshugart@rpainc.biz
School & Office Systems	11781 NE Glisan St	97220	Portland	OR	Rick Peterson	503-255-1106	sosystems@qwestoffice.net
School Equipment, Inc.	7800 Phoenix Ne Suite A	87110	Albuquerque	NM	Tammy Huerena	505-888-5959	thuerena@seinm.com
School Specialty, Inc.	PO Box 1017	54912	Appleton	WI	Greg Hall	916-224-8066	greg.hall@schoolspecialty.com
Schoolhouse Products - CAN	215 Konrad Cres, Unit 2	L3R 8T9	Markham	ON	Hart Sernick	905 475 7737	hart@schoolhouseproducts.com
Schoolhouse Products FL	13517 Prestige Place, Ste 101	33635	Tampa	FL	Walter Posusta	800-942-3360	walter@schoolhouseproducts.com
Signature Products, Inc.	220 Springview Commerce Dr	32713	Debary	FL	Mike Monahan	407-299-0896	mike@signatureschoolproducts.com
SSI Furnishing	6612 Royal Street	64068	Liberty	MO	Mike Sigsbee	816-792-2700	msigsbee@ssifurnishings.com
Tanner North Jersey, Inc.	1251 Lakewood-Farmingdale Ro	07731	Howell	NJ	Mary Ann Engle	732-886-9660	maryann@tannernj.com
Tanner of Pennsylvania, Inc.	7813 Derry Street	17111	Harrisburg	PA	Leysa Stotlemeyer	717-985-9700	leysa@gotanner.com
Terrell Enterprises	106 S Cloverdale Rd	36037	Greenville	AL	Al Brannon	334-382-7415	al@terrellenterprises.com
The Creative Office	721 Legion Way SE	98501	Olympia	WA	Scott Brewer	800-900-1732	sbrewer@creativeof.com
Tom Sexton & Associates	65 Cummings Drive STE A	41094	Walton	KY	Mark Edwards	859-485-7065	mark.e@tomsextonfurniture.com
US Office Solutions		20018	Washington	DC	YELAKE MESERETU	202-526-8767	ymeseretu@usofficesolution.com
WB Mason Co Inc	PO Box 111	02302	Brockton	MA	Frank Viele	508-436-8217	frank.viele@wbmason.com
Working Spaces	1212 S Broadway	80210	Denver	CO	Deborah Russell	720-570-5708	deborah@jordycarter.com
Workplace Resource	828 NE Multnomah	97232	Portland	OR	Jill Domme	503-238-1590	jill_domme@wroregon.com
Workspace Development LLC	dba Open Square	98108	Seattle	WA	Neena McNeil	206-768-0221	nmcneil@open-sq.com
Wyoming Office Products	328 W. Yellowstone	82601	Casper	WY	Jennifer Madden	307-472-7367	jennifer.wyomingofficeproducts@gmail.com

Dealers listed above are shown with physical address. Several dealers cover multiple states with all 50 states covered.



artcorp

At **artcobell**, our passion is building school furniture that supports teachers and students now and into the future. We are driven, by the innovative learning strategies that are changing the face of education, to create great looking, durable, high quality products that meet the needs of active, flexible, personalized learning environments.



Texas-based; USA made.

Because we're nimble and domestic, we can react quickly to your needs. An engaged culture of continuous improvement led by dedicated employees consistently makes furniture tough enough to stand up to the most demanding users.

Our **locally-based national dealer network** is dedicated to making your projects a success, from design through the first day of school. And our **4-6 week average lead times** are the best you'll find in the industry. We are flexible and responsive: uniquely organized to provide personalized solutions and respond to your needs quickly and creatively.

We are **consistently reliable**: delivering what you need when you need it.

We are problem solvers: providing the tools to help schools navigate the demands of today's learning strategies.

We are... the people of artcobell.



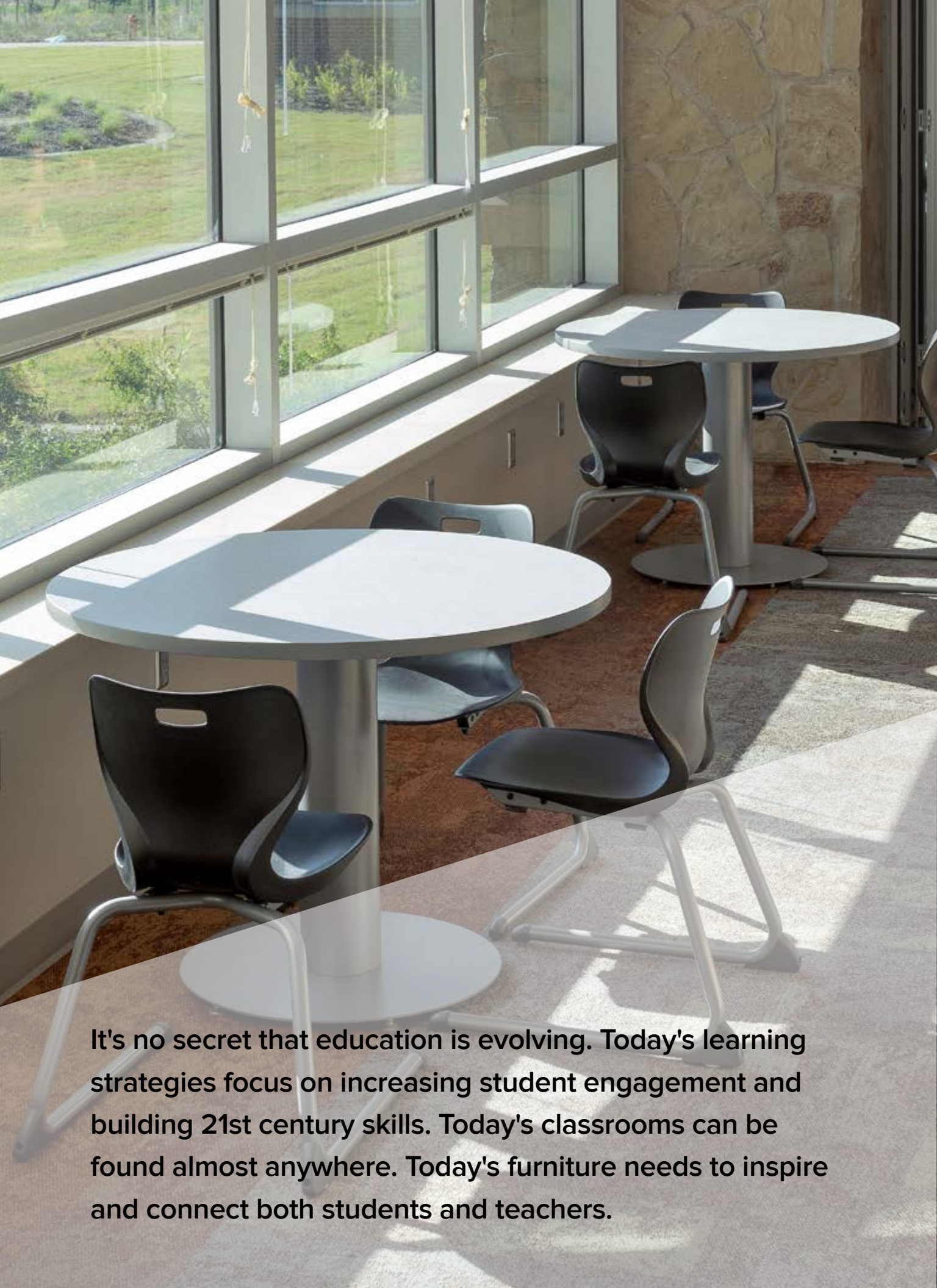

Just like technology, curriculum, and crayons, **artcobell** furniture helps teachers create spaces that spark creativity, enhance collaboration, and expand the imagination.

It's no secret that education is evolving. Today's learning strategies focus on increasing student engagement and building 21st century skills. Today's classrooms can be found almost anywhere. Today's furniture needs to inspire and connect both students and teachers.

[Page 6](#)

SOFT SEATING

[Page 16](#)

SEATING

[Page 40](#)

STUDENT DESKS

[Page 66](#)

TABLES

[Page 100](#)

TEACHER SOLUTIONS

[Page 108](#)

STORAGE

SOFT SEATING

Learning without boundaries begins with a sense of comfort and security.

ENGAGING
SHAPES
BUILT TOUGH
UNLIMITED
CONFIGURABILITY





Circles + Squares

Little shapes that make big ones. All feature a sturdy 3/4" wood base with adjustable glides.

Round

The Round takes "center stage" in our new offering. Available in two heights, the Round can be used by itself or in the middle of any Arc configuration.

Model	Size
SS-RD14	Round 18" diameter x 14"h
SS-RD18	Round 18" diameter x 18"h

Fabric Colors: See page 15



Round Rocker

Variation on the Round, this little seat (in two heights) has the same rocker bottom as our popular MOV stool. Stable, movable and FUN!

Model	Size
SS-RR14	Round 18" diameter x 15"h
SS-RR18	Round 18" diameter x 19"h

Fabric Colors: See page 15



Crescent

The scooped-out front of Crescent gives it two lives. Use as a stool and the scoop accommodates student legs. Put five around a Round to make a fun flower shape.

Model	Size
SS-CR18	18" diameter x 18"h

Fabric Colors: See page 15



2-STEP

Tiered 2-Step for lounging or listening. Use individually or put several together to create mini-stadium seating for a group.

Model	Size
SS-ST230	38"w x 38"d x 32"h

Fabric Colors: See page 15





Square

Our simple block shape in two heights can be used as an ottoman or a seat. Combines with other shapes to create endless configurations.

Model	Size
SS-SQ14	18"w x 18"d x 14"h
SS-SQ18	18"w x 18"d x 18"h

Fabric Colors: See page 15



QUBE

Clever variation on our BLOC (page 27) with a padded seat and 2" legs. Removable, washable slipcovers come in a variety of fabric options.

Model	Size
ASQUBE18	19"w x 19"d x 20"h

Fabric Colors: See page 15



Curved Bench

Designed especially to nest up next to our Radiused Mobile Shelving (page 112), this curved bench is perfect for hanging out. Can be used with our Rectangle Bench too.

Model	Size
SS-BC18	45-degree radius x 18"d

Fabric Colors: See page 15



Rectangle Bench

Simple shape with a multitude of uses. Both sizes work with Arcs, and the 42" length nests up to our Mobile Shelving (page 112).

Model	Size
SS-RC1842	42"w x 18"d x 18"h
SS-RC1848	48"w x 18"d x 18"h

Fabric Colors: See page 15

Arcs

Four configurable pieces that can be used to build all kinds of shapes, from circles to snakes. Can be combined with Rounds, Squares and Rectangle benches.

Model	Size	Description
SS-R818	21"w x 19"d x 18"h	1/8 Round
SS-R418	27"w x 21"d x 18"h	1/4 Round
SS-R318	38"w x 23"d x 18"h	1/3 Round
SS-R218	54"w x 27"d x 18"h	1/2 Round

Fabric Colors: See page 15



Soft Seating | Legs + Casters

Add casters for comfort on the move.

Model	Product Name	Product Description
SSA-LPS3T1.5	Leg	3" leg, Chrome, adds 2/5" to height
SSA-CPS.37T1	Caster	37mm caster, adds 1" to height



Arcs

1/2 Round, 1/3 Round, 1/4 Round, and 1/8 Round - work together and individually



Floorwork

When thinking happens from the ground up.

Rectangle Floor Pad

Full-body comfort for floor work, these pads are designed to stack when they aren't in use, and are lightweight enough to toss on the floor when getting down to business.

Model	Size
SS-RP2414	24"w x 14"d
SS-RP4814	48"w x 14"d

Fabric Colors: See page 15



SPOTS Round Floor Pad

Clever little sit-upon. Spots make floor work a little more comfortable. Washable fabric or environmentally friendly EPU covers zip off for cleaning.

Model	Size
ASPOT16	Round 16" diameter x 3"h

Fabric Colors: See page 15

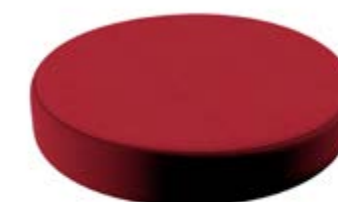

PIXEL Padded Floor Stool

Pixel is a new take on seating that gets students off the ground and focused, but still lets them move. Available with fixed glides or a rocker base.

Model	Size
ASPXL16.4	16" diameter x 4" tall
ASPXL16.R	16" diameter x 4" tall

Fabric Colors: See page 15



Caddy | PIXEL + SPOTS

Conveniently stow up to eight Pixels or ten SPOTS. Standard with casters for easy mobility. Titanium paint finish.

Model	Size
ASPXLCAD.4	18" diameter x 33"h



Lounge

Freestanding comfort.



Lounge

Free-standing comfort. Stylish, modern design works in any setting. An ample gap between back and seat makes cleaning easy and eliminates "stash" zones.

Model	Description	Dimensions
SS-SB24	24" Chair	42"h x 24" w x 30"d
SS-SB48	48" Sofa	42"h x 48" w x 30"d
SS-SB60	60" Sofa	42"h x 60" w x 30"d



Fabric Colors: See page 15

Standard Soft Seating Colors - Silvertex® Vinyl



Additional fabrics available through the Momentum 5-Click program. To view options and order samples: Go to <http://www.momtex.com/mfg/315>

Due to pattern scale and color variations in computer monitors and printers, we strongly suggest you view actual samples before making surface material selections.

Learn more at artcobell.com

SEATING

Learning without boundaries allows choice.

FLEXIBLE
COMFORTABLE
MOVEMENT
SUPPORT
BALANCE
VARIETY. CHOICE.
ENAGEMENT



Alphabet | Engineered for Movement

In today's learning environments, flexibility is paramount and no one does flexibility better than **artcobell**. Alphabet Seating supports the many ways that students move with a variety of sizes and styles that conform to classroom needs.



★ Alphabet Four Leg

The **Alphabet** chair's specially designed shell geometry provides best in class comfort. The dual support channels and heavy duty seat brackets provide strength and durability. Students can flex the back from side to side for maximum comfort.

Four Leg Chair

Classic four-leg style.

Model	Height	Description
AS4L12	12"	Poly Shell
AS4L14	14"	Poly Shell
AS4L16	16"	Poly Shell
AS4L18	18"	Poly Shell
*AS4L16-1	16"	Poly Shell, Seat Pad
*AS4L18-1	18"	Poly Shell, Seat Pad

Glide Package: Nylon (3), Steel (1), Non-Skid (2), Felt (F), Boot

Frame Colors: Chrome (5), Titanium (4), Black (7)

Shell Colors: See page 38

Fabric Colors: See page 39

* extended lead times and premium may apply



Four Leg Caster Chair

Add casters to the Alphabet Four Leg Chair for increased mobility.

Model	Height	Description
AS4C14	14"	Poly Shell
AS4C16	16"	Poly Shell
AS4C18	18"	Poly Shell
*AS4C16-1	16"	Poly Shell, Seat Pad
*AS4C18-1	18"	Poly Shell, Seat Pad

Caster: Hard Wheel Caster (H)

Frame Colors: Chrome (5), Titanium (4), Black (7)

Shell Colors: See page 38

Fabric Colors: See page 39

* extended lead times and premium may apply





Cantilever Chair

A space-saver when you need it. The unique design of the frame and leveling bumpers below the seat allow the Alphabet cantilever chair to safely rest on the work surface when not in use.

Model	Height	Description
ASCL12	12"	Poly Shell
ASCL14	14"	Poly Shell
ASCL16	16"	Poly Shell
ASCL18	18"	Poly Shell
*ASCL16-1	16"	Poly Shell, Seat Pad
*ASCL18-1	18"	Poly Shell, Seat Pad

Glide Package: Nylon (3), Steel (1), Non-Skid (2), Felt (F)

Frame Colors: Chrome (5), Titanium (4), Black (7)

Shell Colors: See page 38

Fabric Colors: See page 39

* extended lead times and premium may apply



★ FLOT



FLOT Four Leg Chair

With a standard 6" seat height, FLOT is a creative alternative to a traditional four leg chair with the patented Alphabet shell design and comfort.

Model	Height	Description
AS4L06	6"	Poly Shell

Glide Package: Nylon (3), Steel (1), Non-Skid (2), Felt (F), Boot

Frame Colors: Chrome (5), Titanium (4), Black (7)

Shell Colors: See page 38

Four Leg Stool

The Alphabet Four Leg Stool offers a smart option for cafeterias and taller work spaces.

Model	Height	Description
AS4ST24	Fixed 24"	Poly Shell
AS4ST30	Fixed 30"	Poly Shell
*AS4ST24-1	Fixed 24"	Poly Shell, Seat Pad
*AS4ST30-1	Fixed 30"	Poly Shell, Seat Pad

Glide Package: Solo Nylon (P)

Frame Colors: Chrome (5), Titanium (4), Black (7)

Shell Colors: See page 38

Fabric Colors: See page 39

* extended lead times and premium may apply



Research supports that physical activity is linked to higher academic performance, better health, and improved behavior so why not provide a seating solution that encourages kids to move and groove?!



★ Alphabet Rocker

Rocker

Engineered for mobility, this gem of a chair provides movers of all sizes a chance to relax or burn off a little energy with the most satisfying sit around.

Model	Height	Description
AS4R14	13"	Poly Shell
AS4R16	15.5"	Poly Shell
AS4R18	17.75"	Poly Shell

Glide Package: Nylon (3)
Frame Colors: Chrome (5)
Shell Colors: See page 38



Sled Stacking Chair

Our Alphabet shell with a stacking base. Stacks 6-8 chairs.

Model	Height	Description
ASSL16	16"	Poly Shell
ASSL18	18"	Poly Shell

Glide Package: Nylon (3), Steel (1)
Frame Colors: Chrome (5), Titanium (4), Black (7)
Shell Colors: See page 38



Task Chair & Swivel Stool

From teachers' desk to lab table, these chairs feature 360-degree swivel and pneumatic height adjustment and comes with a black five-star base. Two adjustable height options.

Model	Height	Description
ASTA18	Adjustable 16"-21"	Poly Shell
*ASTA18-1	Adjustable 16"-21"	Poly Shell, Seat Pad
ASST18	Adjustable 22"-32"	Poly Shell
*ASST18-1	Adjustable 22"-32"	Poly Shell, Seat Pad

Glide/Caster Package: Hard Wheel Caster (H), Bell Glide (B)
Shell Colors: See page 38
Fabric Colors: See page 39
* extended lead times and premium may apply



Let 'em move! Research shows that children who are more active exhibit better focus, faster cognitive processing and higher memory retention than those who spend the day sitting still. These adaptable seating options work in collaborative areas or as alternatives to traditional desk seating.

MOV Stool

MOV is an active stool that promotes user movement and activity. The attractive and simple design with a wider footprint makes MOV extremely stable, safe and fun to use.

Model	Height	Description
ASMOV14	14"	Lounge Poly Shell
ASMOV16	16"	Lounge Poly Shell
ASMOV18	18"	Lounge Poly Shell
ASMOV20	20"	Lounge Poly Shell

Poly Colors: See page 38



MOV Slipcover

Add a little padding to your MOV stool with our NEW! slipcovers. Choose from a variety of fabric options that are removable and washable. Foam padding inside adds 2" to the top surface and 1" all around.

Model	Height	Description
ASMOVCVR1416	16", 18"	Fits 14" and 16" stools
ASMOVCVR1820	20", 22"	Fits 18" and 20" stools

Fabric Colors: See page 39



BLOC & STP

Lightweight and durable, Alphabet BLOC & STP can be used to create fun and flexible learning spaces. Use them together as casual seating, tables or even as an impromptu work surface. Mix and match the various shapes and sizes for creative collaborative learning spaces.

Model	Height	Description
ABLOC1414	14"	Lounge Poly Shell
ABLOC1818	18"	Lounge Poly Shell
ASTP1428	14"/28"	Lounge Poly Shell

Poly Colors: See page 38

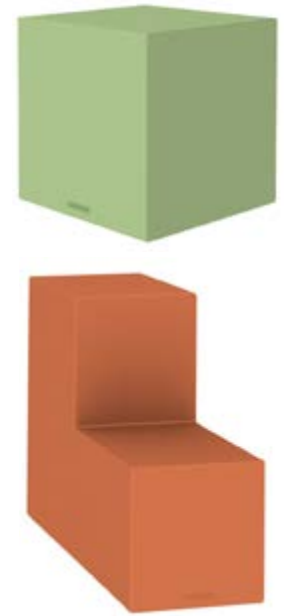

★ STP

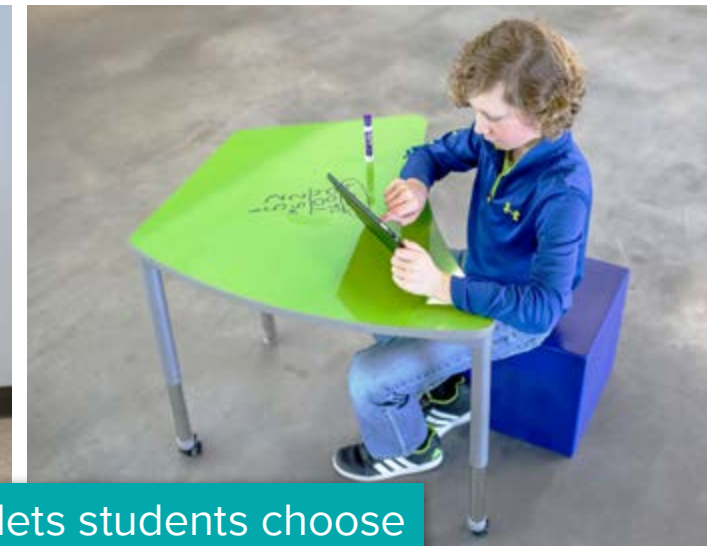

Adaptable seating lets students choose how and where they want to sit.

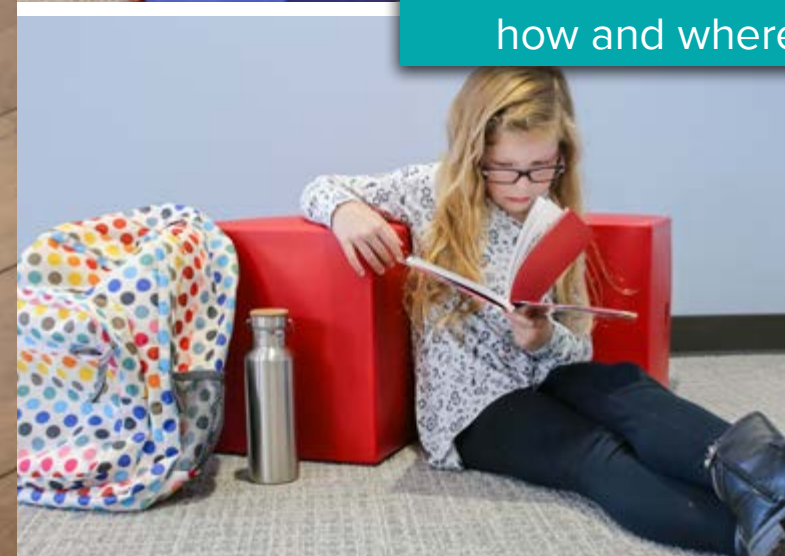

Discover the chair that reinvented student seating! Comfort with a balance of flex and support for a range of movement and seating positions.



★ Discover Four Leg

Four Leg Chair

Discover Four Leg Chair's structural ribs provide support and stability while increasing flexibility for added comfort. Stackable.

Model	Height	Description
D10D	12"	Poly Shell
D10C	14"	Poly Shell
D10B	16"	Poly Shell
D10A	18"	Poly Shell
D10X	18"	Poly A+ Shell
*D10A-1	18"	Poly Shell, Seat Pad
*D10X-1	18"	Poly A+ Shell, Seat Pad

Glide Package: Nylon (3), Steel (1), Non-Skid (2), Felt (F), Boot

Frame Colors: Chrome (5), Titanium (4), Black (7)

Shell Colors: See page 38

Fabric Colors: See page 39

* extended lead times and premium may apply



Choose the size that fits your student.

Discover chair shells come in a range of sizes from 12" - 18" high and A+ - C sized seats.





Cantilever Chair

Discover cantilever chair offers a sleek, stylish option with the same great value.

Model	Height	Description
D30C	14"	Poly Shell
D30B	16"	Poly Shell
D30A	18"	Poly Shell
*D30A-1	18"	Poly Shell, Seat Pad

Glide Package: Nylon (3), Steel (1), Non-Skid (2), Felt (F)
 Frame Colors: Chrome (5), Titanium (4), Black (7)
 Shell Colors: See page 38
 Fabric Colors: See page 39
 * extended lead times and premium may apply

Four Leg Caster Chair

Discover Four Leg Chair with casters for extra mobility.

Model	Height	Description
D16A	18"	Poly Shell
D16X	18"	Poly A+ Shell
*D16A-1	18"	Poly Shell, Seat Pad
*D16X-1	18"	Poly A+ Shell, Seat Pad

Glide Package: Hard Wheel Caster (H)
 Frame Colors: Chrome (5), Titanium (4), Black (7)
 Shell Colors: See page 38
 Fabric Colors: See page 39
 * extended lead times and premium may apply



Four Leg Chair With Bookrack

Roomy bookrack provides a convenient place to store stuff.

Model	Height	Description
D15A	18"	Poly Shell
*D15A-1	18"	Poly Shell, Seat Pad

Glide Package: Nylon (3), Steel (1), Non-Skid (2), Felt (F), Boot
 Frame Colors: Chrome (5), Titanium (4), Black (7)
 Shell Colors: See page 38
 Fabric Colors: See page 39
 * extended lead times and premium may apply



Four Leg Music Chair

Discover shell with an upright pitch to support musicians or anyone who needs to lean in.

Model	Height	Description
D109	18"	Poly Shell, Music
*D109-1	18"	Poly Shell, Music, Seat Pad

Glide Package: Nylon (3), Steel (1), Non-Skid (2), Felt (F), Boot
 Frame Colors: Chrome (5), Titanium (4), Black (7)
 Shell Colors: See page 38
 Fabric Colors: See page 39
 * extended lead times and premium may apply



★ Discover Cantilever

Learn more at artcobell.com

This Rocker is a companion to our Discover line, a harmonic blend of flexibility and support with just a touch of motion.



Rocker

Discover's Rocker provides motion seating with a shape that works with all the other chairs in the room.

Model	Height	Description
D1RC	13"	Poly Shell
D1RB	15.5"	Poly Shell
D1RA	17.75"	Poly Shell

Glide Package: Nylon (3)
 Frame Colors: Chrome (5)
 Shell Colors: See page 38

Four Leg Swivel Stool

Discover's Four-Leg Swivel Stool features a built-in foot ring for added stability and comfort. Available with a 25" - 33" adjustable height range.

Model	Height	Description
D99A	Adjustable 25"-33"	Poly Shell
D99X	Adjustable 25"-33"	Poly A+ Shell
*D99A-1	Adjustable 25"-33"	Poly Shell, Seat Pad
*D99X-1	Adjustable 25"-33"	Poly A+ Shell, Seat Pad

Glide Package: Nylon (3), Steel (1), Non-Skid (2), Felt (F), Boot
 Frame Colors: Chrome (5), Titanium (4), Black (7)
 Shell Colors: See page 38
 Fabric Colors: See page 39
 * extended lead times and premium may apply



Task Chair & Lab Swivel Stool

These two chairs provide adjustability at three different heights, embracing both lab and learning environments. Features include pneumatic seat height adjustment and free-rolling casters. Swivel stool also features a Chrome foot ring.

Model	Height	Description
DP9B	Adjustable 15"-20"	Poly Shell
DP9A	Adjustable 17"-22"	Poly Shell
DP9X	Adjustable 17"-22"	Poly A+ Shell
*DP9A-1	Adjustable 17"-22"	Poly Shell, Seat Pad
*DP9X-1	Adjustable 17"-22"	Poly A+ Shell, Seat Pad
DL9A	Adjustable 24"-34"	Poly Shell
DL9X	Adjustable 24"-34"	Poly A+ Shell
*DL9A-1	Adjustable 24"-34"	Poly Shell, Seat Pad
*DL9X-1	Adjustable 24"-34"	Poly A+ Shell, Seat Pad

Glide/Caster Package: Hardwheel Caster (H); Bell Glide (B)
 Shell Colors: See page 38
 Fabric Colors: See page 39
 * extended lead times and premium may apply



★ Discover Rocker

Our classic **Uniflex** seat offers both comfort and affordability, covering all the basics for function and use.



★ Uniflex
Four Leg

Four Leg Chair

The classic design of the Uniflex four leg chair has been in schools for over 50 years, providing a durable and dependable solution.

Model	Height	Description
7103	13.5"	Poly Shell
7105	15.5"	Poly Shell
7107	17.5"	Poly Shell
7108	18.5"	Poly Shell
*7107-1	17.5"	Poly Shell, Seat Pad
*7108-1	18.5"	Poly Shell, Seat Pad

Glide Package: Nylon (3), Steel (1), Non-Skid (2), Felt (F), Boot

Frame Colors: Chrome (5), Titanium (4), Black (7)

Shell Colors: See page 38

Fabric Colors: See page 39

* extended lead times and premium may apply



Four Leg Caster Chair

The castered Uniflex Four Leg provides lightweight mobility.

Model	Height	Description
7167	17.5"	Poly Shell
*7168	18.5"	Poly Shell
*7167-1	17.5"	Poly Shell, Seat Pad
*7168-1	18.5"	Poly Shell, Seat Pad

Glide Package: Hard Wheel Casters (H)

Frame Colors: Chrome (5), Titanium (4), Black (7)

Shell Colors: See page 38

Fabric Colors: See page 39

* extended lead times and premium may apply



Four Leg Chair With Bookrack

When you need a little extra storage, this extra deep bookrack delivers.

Model	Height	Description
7157	17.5"	Poly Shell, Bookrack
*7157-1	17.5"	*Poly Shell, Bookrack, Seat Pad

Glide Package: Nylon (3), Steel (1), Non-Skid (2), Felt (F), Boot

Frame Colors: Chrome (5), Titanium (4), Black (7)

Shell Colors: See page 38

Fabric Colors: See page 39

* extended lead times and premium may apply





Task Chair & Swivel Stool

The Uniflex Task Chair and Swivel Stool are offered with a pneumatic height adjustment making it comfortable for teachers or in computer lab settings.

Model	Height	Description
7P90	Adjustable 16.25"-20.75"	Poly Shell
*7P98	Adjustable 16.25"-20.75"	Poly A+ Shell
*7P90-1	Adjustable 16.25"-20.75"	Poly A+ Shell, Seat Pad
*7P98-1	Adjustable 16.25"-20.75"	Poly A+ Shell, Seat Pad
7L90	Adjustable 23"-33"	Poly Shell
*7L98	Adjustable 23"-33"	Poly A+ Shell
*7L90-1	Adjustable 23"-33"	Poly Shell, Seat Pad
*7L98-1	Adjustable 23"-33"	Poly A+ Shell, Seat Pad

Glide/Caster Package: Hardwheel Caster (H), Bell Glide (B)

Shell Colors: See page 38

Fabric Colors: See page 39

* extended lead times and premium may apply



Four Leg Swivel Stool

Our Uniflex shell on a sturdy, adjustable swivel stool base.

Model	Height	Description
*7990	Adjustable 23"-31"	Poly Shell
*7990-1	Adjustable 23"-31"	Poly Shell, Seat Pad

Glide Package: Nylon (3), Steel (1), Non-Skid (2), Felt (F), Boot

Frame Colors: Chrome (5), Titanium (4), Black (7)

Shell Colors: See page 38

Fabric Colors: See page 39

* extended lead times and premium may apply



Solid Plastic Stacking Chair

The Solid Plastic Four Leg Stacking Chair is our best selling Solid Plastic chair, designed with an X-frame for proper weight distribution and nylon bumpers for level stacking.

Model	Height	Description
X105	15.5"	Navy seat only
X107	17.5"	Navy seat only

Glide Package: Nylon (3), Steel (1), Non-Skid (2), Felt (F), Boot

Frame Colors: Chrome (5), Titanium (4), Black (7)

Seat + Back Color: Navy (N)

Mobile Swivel Stool

Practical and fun, this mobile, adjustable stool works almost anywhere, from small group centers to labs. The mobile alternative to our popular 0801 Stool. Optional padded slipcover is also available.

Model	Height	Description
DP08	Adjustable 16"-21"	Poly Seat

Glide/Caster Package: Hardwheel Caster (H), Bell Glide (B)

Shell Colors: See page 38



Stool Seat Slipcover

Designed to fit our popular stool seats, this padded slipcover provides comfort and color. Removable for cleaning. Available in our fabric and EPU options. Fits 13-1/2" diameter stools 0801/0802 and DP08.

Model	Description
08CVR	Padded slipcover for 13-1/2" stool seats

Fabric Colors: See page 39



* DP08 stool shown with 08CVR padded cover

Four Leg Stool

The Four Leg Lab Stool in two heights is available with a polypropylene top.

Model	Height	Description
0801	Adjustable 19"-27.5"	Poly Seat
0802	Adjustable 23.5"-32"	Poly Seat

Glide Package: Nylon (3), Steel (1), Non-Skid (2), Felt (F), Boot

Frame Colors: Chrome (5), Titanium (4), Black (7)

Seat Colors: See page 38



Adaptable Seating Poly Colors | MOV, BLOC, STP

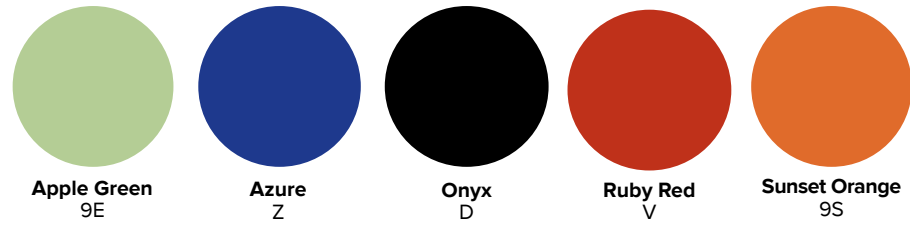

Poly Colors (Alphabet, Discover, Uniflex)

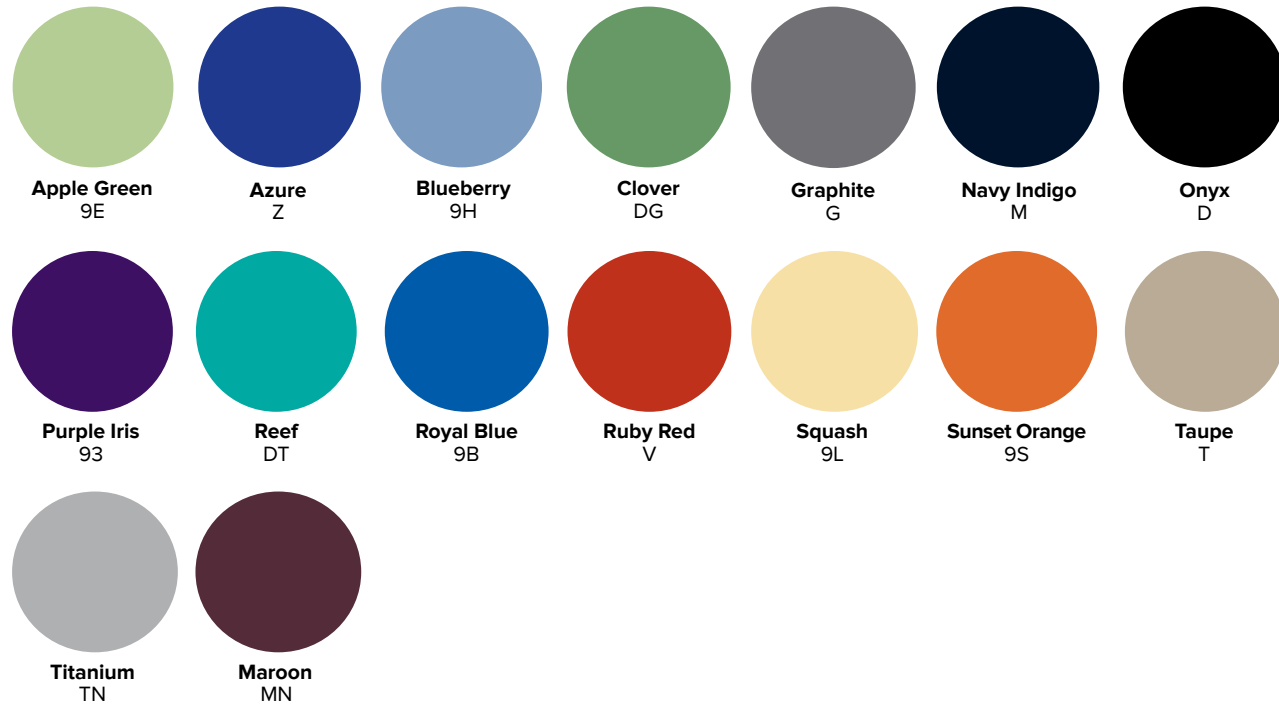

Metal Frames

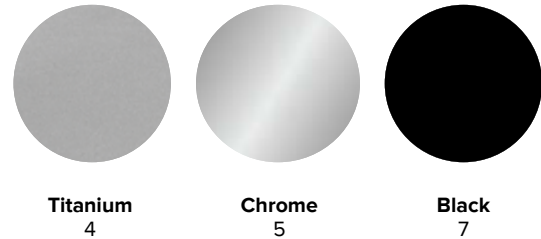

Standard Fabric Colors (Seat Pads)



Additional fabrics available through the Momentum 5-Click program. To view options and order samples: Go to <http://www.momtex.com/mfg/315>

STUDENT DESKS

Learning without boundaries inspires creativity.

INSPIRED SHAPES

MULTIPLE GROUPINGS

CONFIGURABLE

MIX + MATCH

CREATIVE

WORKSPACES

SIT-TO-STAND

COLLABORATIVE. PERSONALIZED. MOBILE.



[Page 49](#)

Aperture
Shape Desk

Shape desks. These fun, imaginative and mobile-friendly shapes can easily reconfigure to create a wide range of individual or group layouts. Available with durable high pressure laminate surfaces and a variety of colored edge options.



Beta

Imaginative shape is accessible on two sides and configures for small and large groups.

Model	Size
DST-BT2233E	22" x 33" x 3/4"
DHT-BT2233E	22" x 33" x 1-1/8"

Leg Kit + Accessories: See pages 50-51
 Surface Material: High pressure laminate, see page 64
 Edge Options: See page 64

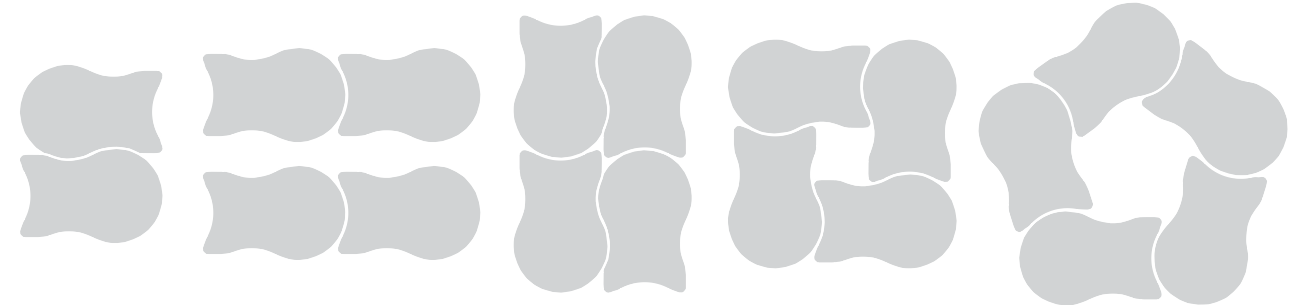

Expanse

Organic variation on the classic rectangle with ample work surface. Accessible from 2 sides.

Model	Size
DST-EX2232E	23" x 32" x 3/4"
DHT-EX2232E	23" x 32" x 1-1/8"

Leg Kit + Accessories: See pages 50-51
 Surface Material: High pressure laminate, see page 64
 Edge Options: See page 64



Expanse | T-Leg

Model	Size
DST-EX2232E	22" x 32" x 3/4"
DHT-EX2232E	22" x 32" x 1-1/8"

Leg Kit + Accessories: See pages 50-51
 Surface Material: High pressure laminate, see page 64
 Edge Options: See page 64





★ Kite Desk

Shape Student Desks

Offer a variety of heights, from seated to standing, to enhance engagement. Wheelbarrow the legs for mobility.

Kite

Our most versatile shape with ample worksurface and access from 3 sides. Configures for groups up to 9.

Model	Size
DST-KT3032E	32" x 30" x 3/4"
DHT-KT3032E	32" x 30" x 1-1/8"

Leg Kit + Accessories: See pages 50-51
 Surface Material: High pressure laminate, see page 64
 Edge Options: See page 64

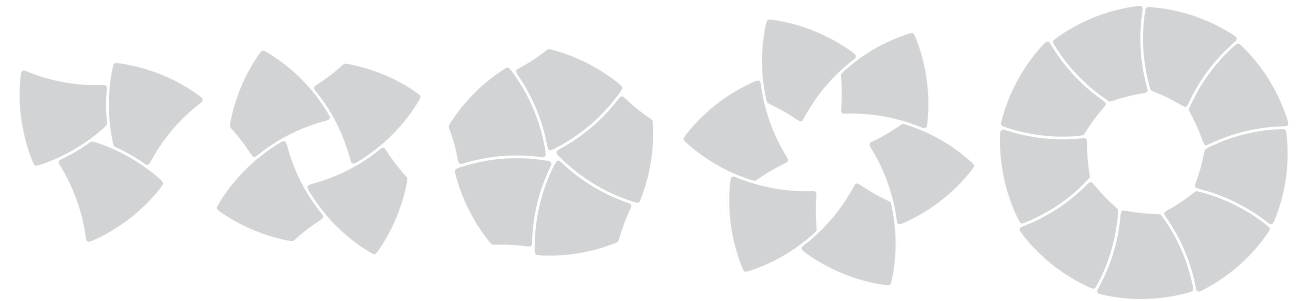

★ Kite Desk



Linc

Straight-sided version of our Beta with access from both sides. Configures in groups or rows.

Model	Size
DST-LC2232E	22" x 32" x 3/4"
DHT-LC2232E	22" x 32" x 1-1/8"

Leg Kit + Accessories: See pages 50-51
 Surface Material: High pressure laminate, see page 64
 Edge Options: See page 64



Rectangle

Classic shape with ample work surface. Accessible from 2 sides.

Model	Size
DST-RC2026E	20" x 26" x 3/4"
DST-RC2036E	20" x 36" x 3/4"
DHT-RC2026E	20" x 26" x 1-1/8"
DHT-RC2036E	20" x 36" x 1-1/8"

Leg Kit + Accessories: See pages 50-51
 Surface Material: High pressure laminate, see page 64
 Edge Options: See page 64



Rectangle | T-Leg

Model	Size
DST-RC2026E	20" x 26" x 3/4"
DHT-RC2026E	20" x 26" x 1-1/8"
DST-RC2036E	20" x 36" x 3/4"
DHT-RC2036E	20" x 36" x 1-1/8"

Leg Kit + Accessories: See pages 50-51
 Surface Material: High pressure laminate, see page 64
 Edge Options: See page 64



Trapezoid 6

Classic singles-access shape configures easily to seat small and large groups.

Model	Size
DST-T6E	20" x 32" x 3/4"
DHT-T6E	20" x 32" x 1-1/8"

Leg Kit + Accessories: See pages 50-51
 Surface Material: High pressure laminate, see page 64
 Edge Options: See page 64



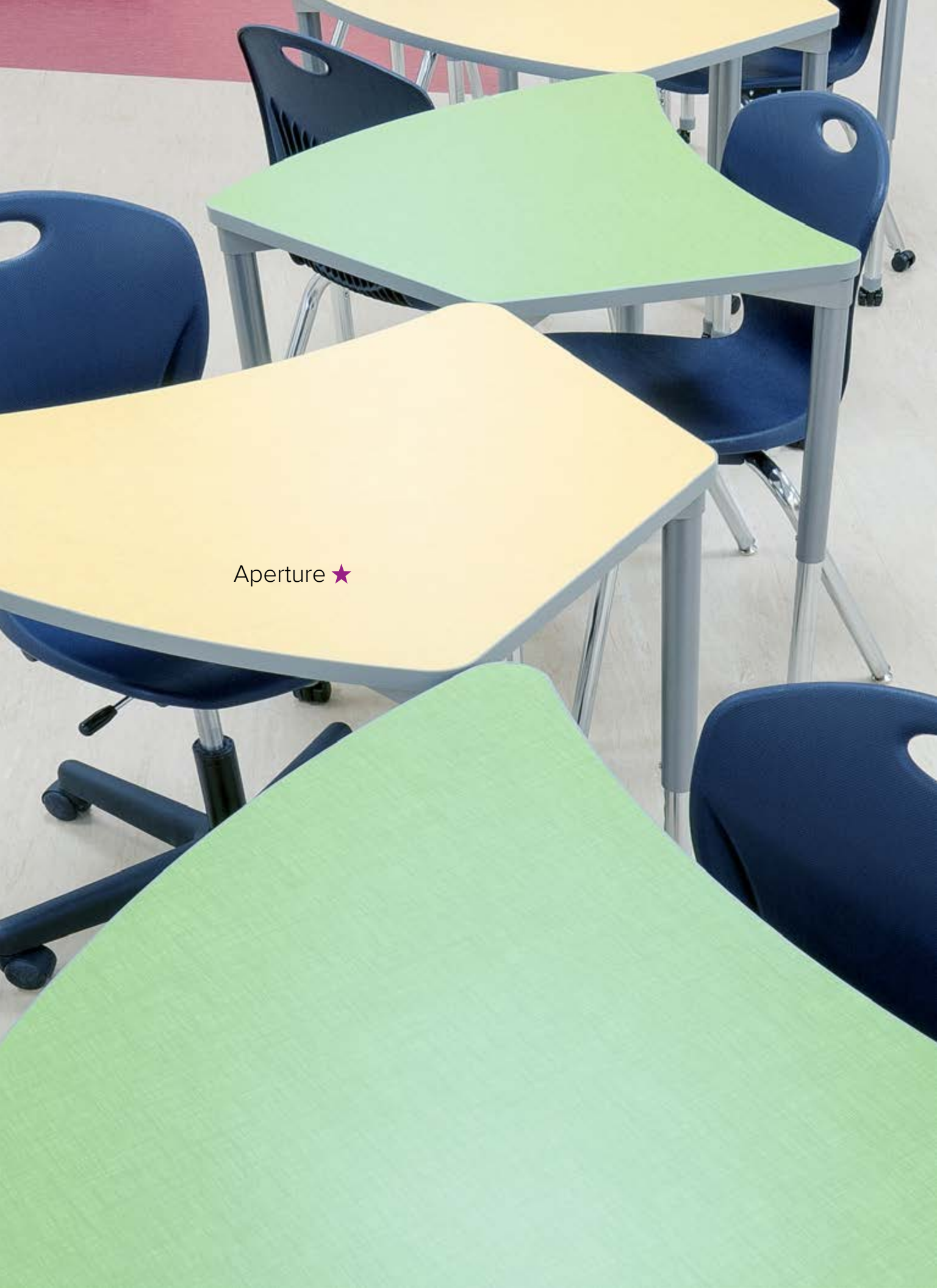

Aperture ★

Aperture

Accessible from two sides. Configures organically for groups of 4, 6, 8 and more.

Model	Size
DST-AP1830E	27" x 30" x 3/4"
DHT-AP1830E	27" x 30" x 1-1/8"

Leg Kit + Accessories: See pages 50-51
 Surface Material: High pressure laminate, see page 64
 Edge Options: See page 64

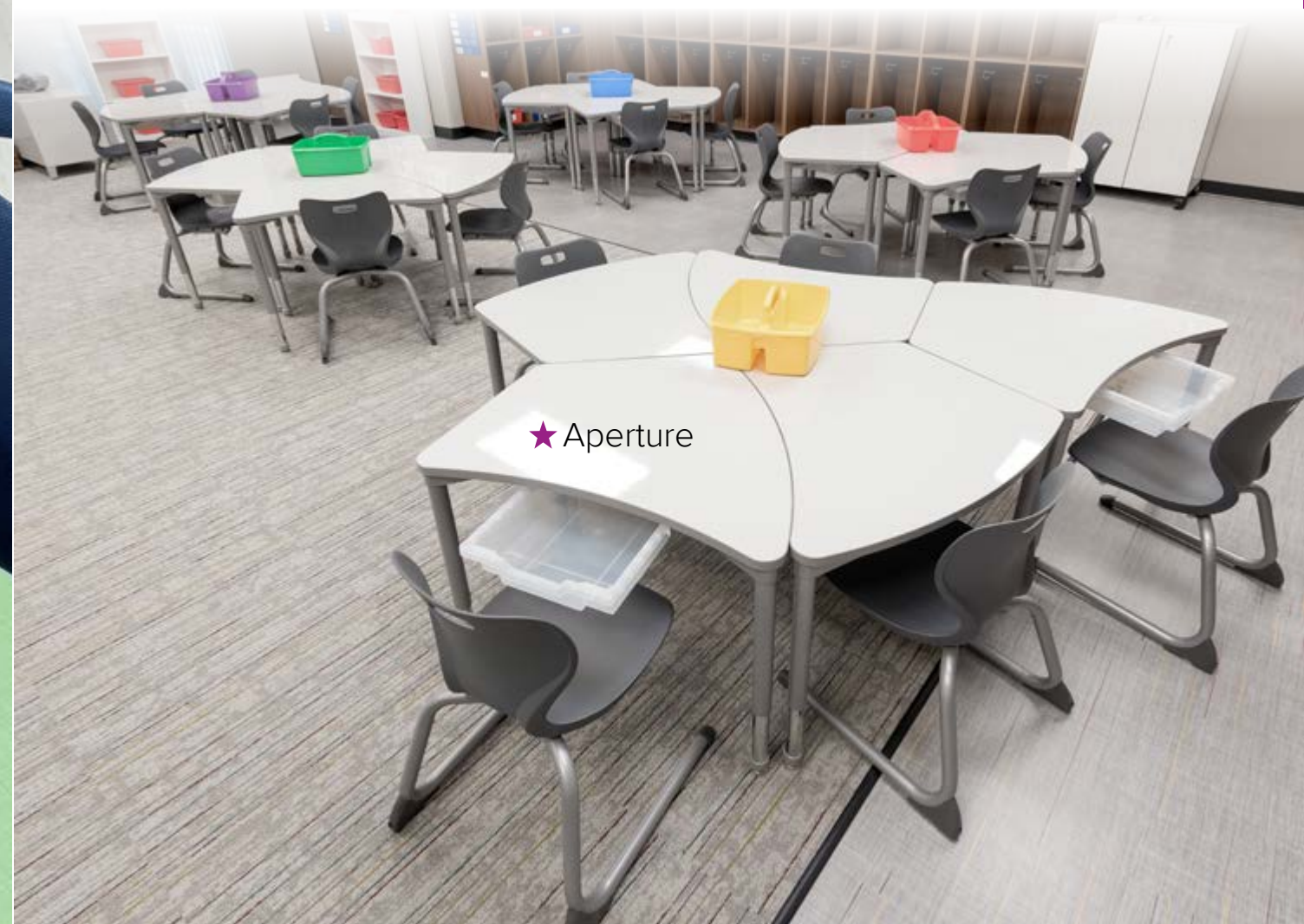
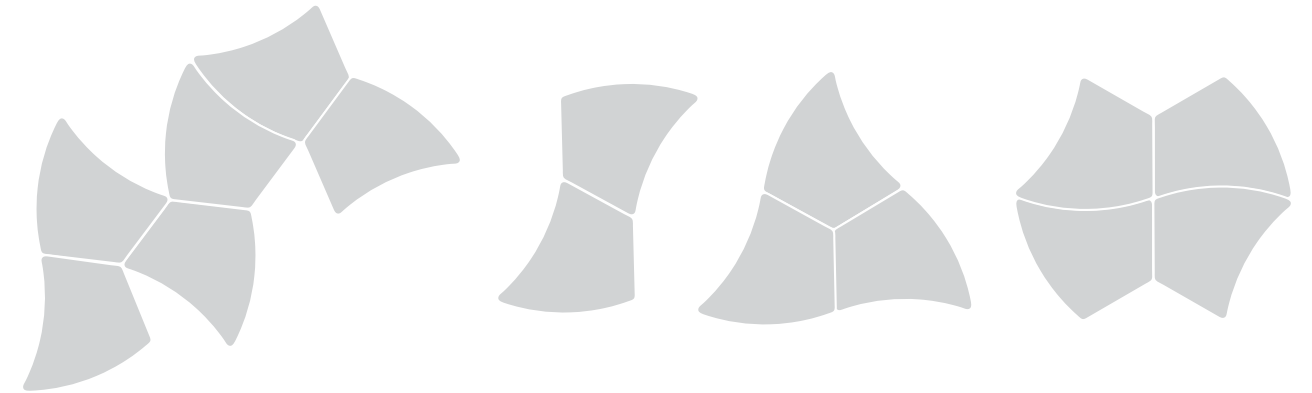

★ Aperture



Sail

Available in two sizes, the classic triangle configures in a wide range of groups. Accessible from all 3 sides.

Model	Size
DST-SL2730E	27" x 30" x 3/4"
DHT-SL2730E	27" x 30" x 1-1/8"
DST-SL3034E	30" x 34" x 3/4"
DHT-SL3034E	30" x 34" x 1-1/8"

Leg Kit + Accessories: See pages 50-51
 Surface Material: High pressure laminate, see page 64
 Edge Options: See page 64



Tri-Top

Variation on the classic single-access triangle configures for up to 4.

Model	Size
DST-TT2828E	28" x 28" x 3/4"
DHT-TT2828E	28" x 28" x 1-1/8"

Leg Kit + Accessories: See pages 50-51
 Surface Material: High pressure laminate, see page 64
 Edge Options: See page 64

Shape Desks | Legs

Choose the right legs for your student desks

Model	Description	RC2026E RC2036E		EX2232E		AP1830E		TT2828E		T6E		KT3032E		BT2233E		LC2233E		SL2730E SL3034E	
		DST	DHT	DST	DHT	DST	DHT	DST	DHT	DST	DHT	DST	DHT	DST	DHT	DST	DHT	DST	DHT
DSLPL-4AAP	22"-34" adj. seated height legs, 1.5" dia	✓		✓		✓		✓		✓		✓		✓		✓		✓	
DTLP-4ATP	19"-29" adj. table height legs, 2" dia		✓		✓		✓		✓		✓		✓		✓		✓		✓
DTLP-4ASP	27"-42" adj. stand height legs, 2" dia		✓		✓		✓		✓		✓		✓		✓		✓		✓
DSLK-2F29G	29" fixed height t-legs, 2pk	✓		✓															
TA-CPS37T4	37mm casters, use with DSLP legs, 4pk	✓		✓		✓		✓		✓		✓		✓		✓		✓	
TA-CPS4	50mm casters, use with DTLP legs, 4pk	✓		✓		✓		✓		✓		✓		✓		✓		✓	

Shape Desks | Accessories

Improve the way any desk performs with accessories that add functionality.

Model	Product Name	Product Description
TA-BBFM17	Book Box	Full Metal, 17.5"w, Titanium, 4-pack
TA-BBM16	Book Box	Metal Perforated, 16"w, Titanium, 4-pack
TA-BBM22	Book Box	Metal Perforated, 21.75"w, Titanium, 4-pack
TA-BBP17	Book Box	Poly-Translucent, 17.13"w, 4-pack
TA-BBW15	Book Box	Wire Frame, 15"w, Chrome, 4-pack
MSCA-TK1203.T	Tote Tray	Translucent, 3"x12", 6-pack
MSCA-TK1206.T	Tote Tray	Translucent, 6"x12", 6-pack
MSCA-TK1212.T	Tote Tray	Translucent, 12"x12", 2-pack
TA-TTR.2	Tote Tray Rail	White Metal, 2-pack
TA-TTR.6	Tote Tray Rail	White Metal, 6-pack
MSCA-SK1216.W	Markerboard	Hand-held, 12x16, White Acrylic, 6-pack
MBH-DMB1.4	Hardware	Desk Bracket for MSCA-SK1216W Markerboard, 4-pack
TA-BPH1	Hardware	Back Pack Hook, Chrome



Tote Tray + Rail

The Ultimate in flexibility! Expand or reduce classroom capacity with a simple twist. Our Flip Top Desk is meant to move day to day, hour to hour, or activity to activity. Move it. Flip it. Nest it. Store it.

COLLABORATE



INDIVIDUAL WORK



Flip Top

These revolutionary desks come in three shapes (Beta, Linc and Rectangle) and are equipped with casters allowing you to easily move them throughout the space.

Model	Size	Top Material Edge	Height
FTBT2233E	22" X 33"	Laminate Banded Flat Edge	29"
FTRC2228E	22" X 28"	Laminate Banded Flat Edge	29"
FTLC2232E	22" X 32"	Laminate Banded Flat Edge	29"

Frame Color: Titanium (4)
 Surface Material: See page 64
 Edge Options: See page 64



NEST + STORE

Flip Top ★





Stacking Desk

Stackable desk with a creative double curve shape allows the space to flex up and down as needed. Roomy surface allows for one to two users.

Model	Size	Top Material Edge	Height
SA2232E	22"x32"	Laminate Edge Band	Adjustable 22"-30"

Glide: 2 Nylon/2 Caster (3W)
 Frame Color: Titanium (4)
 Surface Material: See page 64
 Edge Options: See page 64



Stow away stacking desks till you need them. Stacks up to 4 high.

Sit-to-Stand Desk

The next generation in flexible desks. Sit-to-Stand is fully adjustable from 28" to 41" and moves easily around a room or room-to-room. Roomy work surface and elegant base design allows for one or two users.

Model	Size	Top Material Edge	Height
STS-RC2228E	22"x28"	Laminate Edge Band	Adjustable 28"-41"

Frame Color: Titanium (4)
 Surface Material: See page 64
 Edge Options: See page 64



Flex smoothly to your choice of height from 28" - 41".

Open Front with a twist. **artcobell's** traditional open front desk features a sturdy poly box in a variety of colors that can be coordinated with top and edge options. Generous 20" x 26" size offers the largest work surface in the industry.



Open Front | Poly Book Box

The Open Front Desk features convenient storage for classroom materials. Available in 18" x 24" and 20" x 26" top sizes both with a 22" - 30" adjustable height leg. DAJ models feature our exclusive jumbo size bookbox.

Model	Size	Top Material Edge	Height
DA0D3	18" x 24"	Laminate Clear Edge	22" - 30"
DA0DE	18" x 24"	Laminate Banded Flat Edge	22" - 30"
DA0DS	18" x 24"	Solid Plastic	22" - 30"
DA0E3	20" x 26"	Laminate Clear Edge	22" - 30"
DA0EE	20" x 26"	Laminate Banded Flat Edge	22" - 30"
DA0ES	20" x 26"	Solid Plastic	22" - 30"
*DAJ63	20" x 26"	Laminate Clear Edge	22" - 30"
*DAJ6E	20" x 26"	Laminate Banded Flat Edge	22" - 30"

Glide: Nylon (3)

Frame Color: Titanium (4), Chrome (5), Black (7)

Surface Material: See page 64

Edge Options: See page 64

* extended lead times and premium may apply



Open Front | Metal Book Box

The R90 open front desk has an adjustable height range of 22" - 30" with a rectangular top and built-in metal book box.

Model	Size	Top Material Edge	Height
R90D3	18" x 24"	Laminate Clear Edge	22" - 30"
R90DE	18" x 24"	Laminate Banded Flat Edge	22" - 30"
R90DS	18" x 24"	Solid Plastic	22" - 30"
R90E3	20" x 26"	Laminate Clear Edge	22" - 30"
R90EE	20" x 26"	Laminate Banded Flat Edge	22" - 30"
R90ES	20" x 26"	Solid Plastic	22" - 30"

Glide: Nylon (3)

Frame Color: Titanium (4), Chrome (5), Black (7)

Surface Material: See page 64

Edge Options: See page 64



The 7SD Series provides classic solutions with a reliable, cost-effective frame. Available with both adjustable and fixed height legs in Titanium, Chrome or Black.

7SD Series | Trapezoid | 4-Leg

The 7SD Series Student Desk with a trapezoid top shape.



Model	Size	Top Material Edge	Height
7SD4AT3	20" x 32"	Laminate Clear Edge	22" - 30"
7SD4ATE	20" x 32"	Laminate Banded Flat Edge	22" - 30"
*7SD4F30T3	20" x 32"	Laminate Clear Edge	Fixed, 30"
*7SD4F30TE	20" x 32"	Laminate Banded Flat Edge	Fixed, 30"
*7SD4F42T3	20" x 32"	Laminate Clear Edge	Fixed, 42"
*7SD4F42TE	20" x 32"	Laminate Banded Flat Edge	Fixed, 42"

Glide: Nylon (3)

Frame Color: Titanium (4), Chrome (5), Black (7)

Surface Material: See page 64

Edge Options: See page 64

* extended lead times and premium may apply



*7SD4ADE shown above



*7SD4H6E shown above

7SD Series | Rectangle | 4-Leg

Classic rectangle shape in three top sizes, including ADA compliant options.

Model	Size	Top Material Edge	Height
7SD4A03	18" x 24"	Laminate Clear Edge	22" - 30"
7SD4A0E	18" x 24"	Laminate Banded Flat Edge	22" - 30"
7SD4A0S	18" x 24"	Solid Plastic	22" - 30"
7SD4H03	18" x 24"	Laminate Clear Edge	34" - 42"
7SD4H0E	18" x 24"	Laminate Banded Flat Edge	34" - 42"
7SD4H0S	18" x 24"	Solid Plastic	34" - 42"
7SD4A63	20" x 26"	Laminate Clear Edge	22" - 30"
7SD4A6E	20" x 26"	Laminate Banded Flat Edge	22" - 30"
7SD4A6S	20" x 26"	Solid Plastic	22" - 30"
7SD4H63	20" x 26"	Laminate Clear Edge	34" - 42"
7SD4H6E	20" x 26"	Laminate Banded Flat Edge	34" - 42"
7SD4H6S	20" x 26"	Solid Plastic	34" - 42"
7SD4AD3	20" x 36"	Laminate Clear Edge	26" - 34"
7SD4ADE	20" x 36"	Laminate Banded Flat Edge	26" - 34"
*7SD4F3003	18" x 24"	Laminate Clear Edge	Fixed, 30"
*7SD4F300E	18" x 24"	Laminate Banded Flat Edge	Fixed, 30"
*7SD4F300S	18" x 24"	Solid Plastic	Fixed, 30"
*7SD4F4203	18" x 24"	Laminate Clear Edge	Fixed, 42"
*7SD4F420E	18" x 24"	Laminate Banded Flat Edge	Fixed, 42"
*7SD4F420S	18" x 24"	Solid Plastic	Fixed, 42"
*7SD4F3063	20" x 26"	Laminate Clear Edge	Fixed, 30"
*7SD4F306E	20" x 26"	Laminate Banded Flat Edge	Fixed, 30"
*7SD4F306S	20" x 26"	Solid Plastic	Fixed, 30"
*7SD4F4263	20" x 26"	Laminate Clear Edge	Fixed, 42"
*7SD4F426E	20" x 26"	Laminate Banded Flat Edge	Fixed, 42"
*7SD4F426S	20" x 26"	Solid Plastic	Fixed, 42"

Glide: Nylon (3)

Frame Color: Titanium (4), Chrome (5), Black (7)

Surface Material: See page 64

Edge Options: See page 64

* extended lead times and premium may apply





7SD Series | Tri-Top | 3-Leg

The 7SD Tri-Top table provides a sturdy 3-leg alternative with the same options as our 4-leg student desks.

Model	Size	Top Material Edge	Height
7SD3A3	28" x 28"	Laminate Clear Edge	22" - 30"
7SD3AE	28" x 28"	Laminate Banded Flat Edge	22" - 30"
7SD3AS	28" x 28"	Solid Plastic	22" - 30"
7SD3H3	28" x 28"	Laminate Clear Edge	34" - 42"
7SD3HE	28" x 28"	Laminate Banded Flat Edge	34" - 42"
7SD3HS	28" x 28"	Solid Plastic	34" - 42"
*7SD3F303	28" x 28"	Laminate Clear Edge	Fixed, 30"
*7SD3F30E	28" x 28"	Laminate Banded Flat Edge	Fixed, 30"
*7SD3F30S	28" x 28"	Solid Plastic	Fixed, 30"
*7SD3F423	28" x 28"	Laminate Clear Edge	Fixed, 42"
*7SD3F42E	28" x 28"	Laminate Banded Flat Edge	Fixed, 42"
*7SD3F42S	28" x 28"	Solid Plastic	Fixed, 42"

Glide: Nylon (3)
 Frame Color: Titanium (4), Chrome (5), Black (7)
 Surface Material: See page 64
 Edge Options: See page 64
 * extended lead times and premium may apply

4100 Cantilever

The Cantilever Student Desk offers unrestricted leg room. Available in 20" x 26" top size with fixed 27" or fixed 29" height.

Model	Size	Top Material Edge	Height
4F276E	20" x 26"	Laminate Banded Flat Edge	Fixed, 27"
4F276S	20" x 26"	Solid Plastic	Fixed, 27"
4F296E	20" x 26"	Laminate Banded Flat Edge	Fixed, 29"
4F296S	20" x 26"	Solid Plastic	Fixed, 29"

Glide: Nylon (3)
 Frame Color: Titanium (4), Black (7)
 Surface Material: See page 64
 Edge Options: See page 64



Desks | Accessories

Improve the way that any desk performs with accessories that add functionality

Category	Model	Description
Bookboxes	TA-BBFM17	Full Metal, 17.5"w, Titanium
	TA-BBM16	Metal Perforated, 16"w
	TA-BBM22	Metal Perforated, 21.75"w
	TA-BBP17	Poly-Translucent, 17.13"w
	TA-BBW15	Wire Frame, 15"w, Chrome
Totes & Rails	MSCA-TK1203.T	Tote Tray Translucent, 3"x12"
	MSCA-TK1206.T	Tote Tray Translucent, 6"x12"
	MSCA-TK1212.T	Tote Tray Translucent, 12"x12"
	TA-TTR	Tote Tray Rail White metal
Accessories	MSCA-SK1216.W	Hand-Held Acrylic Markerboard, 12"x16"
	MBH-DMB1.4	Desk Bracket for Markerboard
	TA-BPH1	Back Pack Hook

7SD Tri Top ★

These all-in-one options provide simplicity and the comfort you need. Choose the chair shell and configuration that meets your needs.



D75 Four Leg Combo RH Entry

Features the popular Discover shell with standard fixed bookrack.

Model	Size	Top Material Edge	Seat Height
D75A3	18" x 24"	Laminate Clear Edge	18"
D75AS	18" x 24"	Solid Plastic	18"
D75X3	18" x 24"	Laminate Clear Edge	18"
D75XS	18" x 24"	Solid Plastic	18"

Glide: Nylon (3)

Frame Color: Titanium (4), Chrome (5) Black (7)

Shell Color: See page 65

Surface Material: See pages 64-65

* extended lead times and premium may apply

745 Four Leg Combo RH Entry

The Uniflex four leg combination desk includes comes standard with a fixed wire bookrack.

Model	Size	Top Material Edge	Height
74573	18" x 24"	Laminate Clear Edge	17.5"
7457S	18" x 24"	Solid Plastic	17.5"

Glide: Nylon (3)

Frame Color: Titanium (4), Chrome (5) Black (7)

Shell Color: See page 65

Surface Material: See pages 64-65



H457 Four Leg Combo RH Entry

The Solid Plastic four leg combination desk comes standard with a fixed wire bookrack.

Model	Size	Top Material Edge	Height
H457S	18" x 24"	Solid Plastic	17.5"

Glide: Nylon (3)

Frame Color: Titanium (4), Chrome (5) Black (7)

Seat & Back Color: Navy (N)

Surface Color: Grey Spectrum (J), Sugar Maple (D), Walnut (W)



Sled Combo

This combination desk features a convenient dual entry sled base and Discover shell. Standard with fixed wire bookrack.

Model	Size	Top Material Edge	Seat Height
*D85A3	18" x 24"	Laminate Clear Edge	18"
*D85AS	18" x 24"	Solid Plastic	18"
*D85X3	18" x 24"	Laminate Clear Edge	18"
*D85XS	18" x 24"	Solid Plastic	18"

Frame Color: Chrome (5)

Shell Color: See page 65

Surface Material: See page 64

* extended lead times and premium may apply



Standard Laminates



Premium Markerboard Laminates

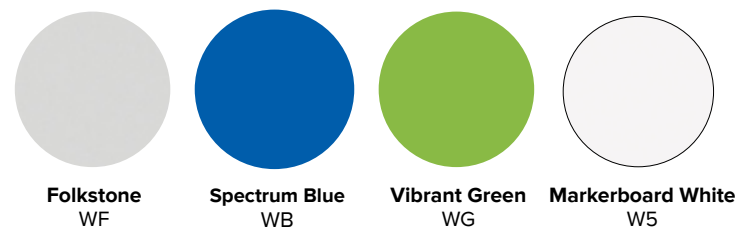

Edge Band

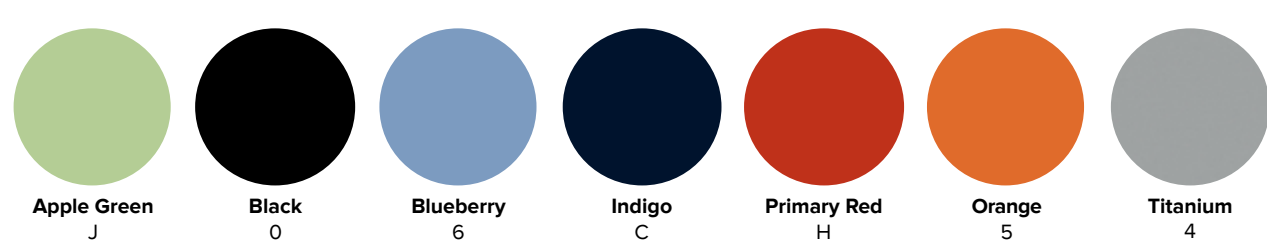

Additional designs available: Most Wilsonart® Laminates are available as special orders. Minimum quantities and extended lead times will apply. Any laminate design that is **not** part of the Artcobell collection shown here will be priced as **premium**.

Poly Colors (DA0D, D75, 7457)

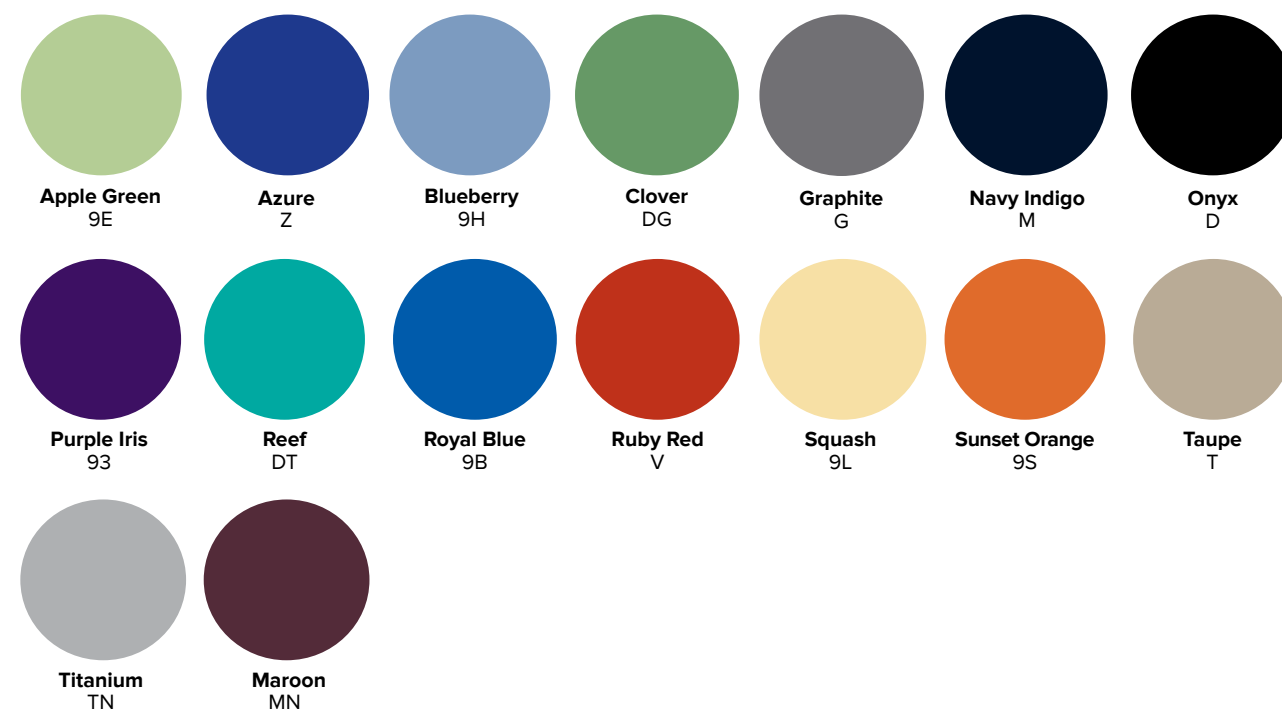

Metal Frames

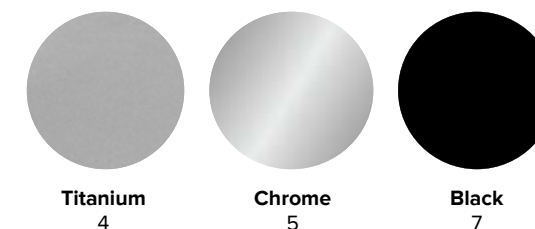

Solid Plastic *Subject to current lead times

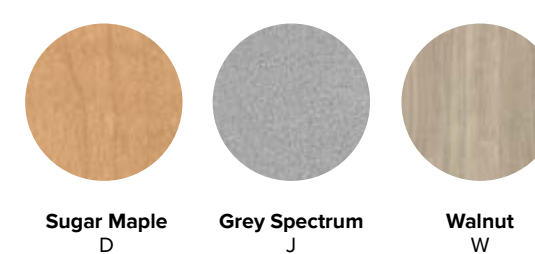

TABLES

Learning without boundaries requires flexibility.

FLIPPING
NESTING
WRITABLE

PRESENTATION. INSPIRATION.

ACTIVE
LEARNING

CONFIGURATION. COLLABORATION.

AGILE SPACES. STUDENT CENTERED.



Fun, mobile Shape Tables feature durable high pressure laminate surfaces with coordinated edge banding.

A collection of organic shapes that work individually or intuitively combine with others. Creating an infinite array of configurations.



MIX + MATCH

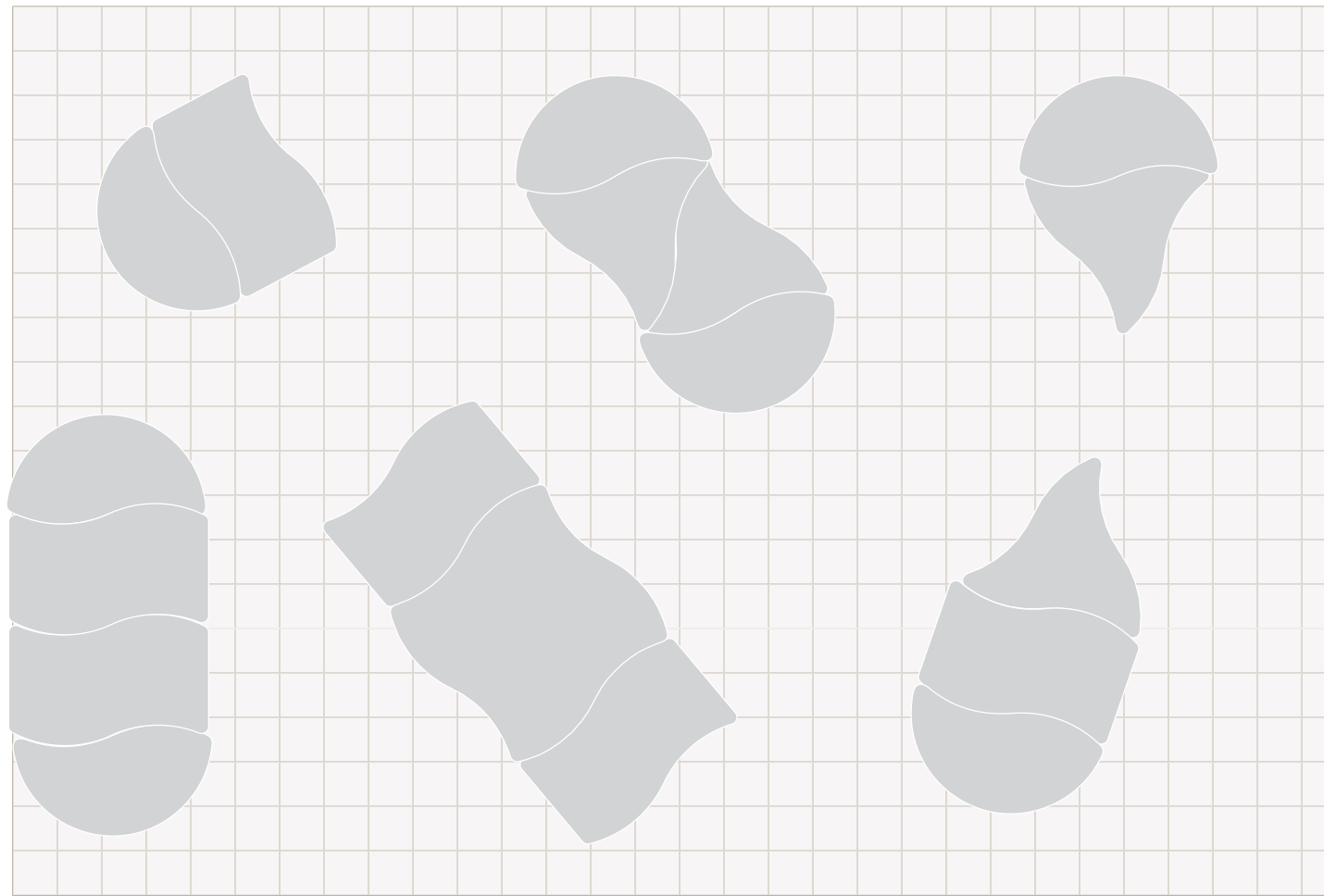



Nova

Roomy 60" work surface that supports up to six people as standalone or pairs with Expanse, Gravity or Nebula shapes.

Model	Size
DTT-NV60E	60"

Surface Material: See page 98
 Edge Options: See page 98
 Leg Options: See page 77

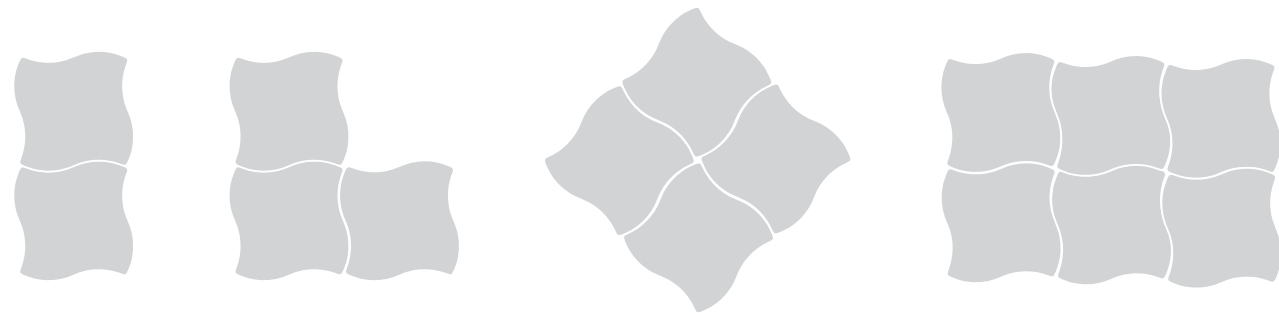

Gravity

Innovative 50" work surface that supports small teams or large group collaborations. Works with Expanse, Nova or Nebula shapes.

Model	Size
DTT-GV50E	50"

Surface Material: See page 98
 Edge Options: See page 98
 Leg Options: See page 77



Nebula

Large 30" x 54" work surface that supports up to three people as standalone or pairs with Expanse, Nova or Gravity shapes.

Model	Size
DTT-NB3054E	30" x 54"

Surface Material: See page 98
 Edge Options: See page 98
 Leg Options: See page 77



Expanse

Generous 30" x 54" work surface that support up to six people as a stand-alone or pairs with Gravity, Nova or Nebula shapes.

Model	Size
DTT-EX3054E	30" x 54"

Surface Material: See page 98
 Edge Options: See page 98
 Leg Options: See page 77

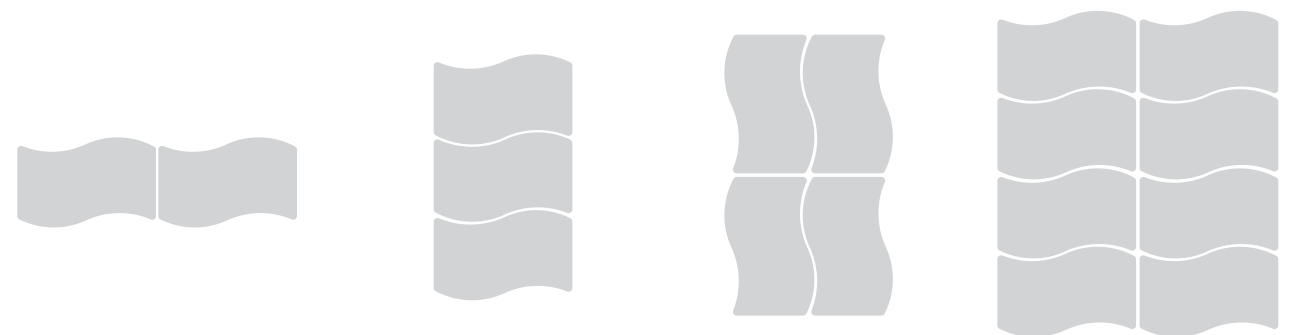

These shapes can work on their own for groups of 2-3 or configure in many ways to expand the workspace. Consider casters for easy movement or "wheel-barrow" with two casters for stability.



Aperture

Seats three easily, or group tables together to seat more.

Model	Size
DTT-AP2440E	24"x 40"

Surface Material: See page 98
 Edge Options: See page 98
 Leg Options: See page 77



Trapezoid

60" long work surface provides ample room for three or group more tables to seat 8-14.

Model	Size
DTT-TZ3060E	30" x 60"

Surface Material: See page 98
 Edge Options: See page 98
 Leg Options: See page 77





3P-120

60" work surface seats six individually, or creatively pair up for larger groups. Requires six post legs, specified separately.

Model	Size
DTT-3P3060E	30" x 60"

Surface Material: See page 98
 Edge Options: See page 98
 Leg Options: See page 77

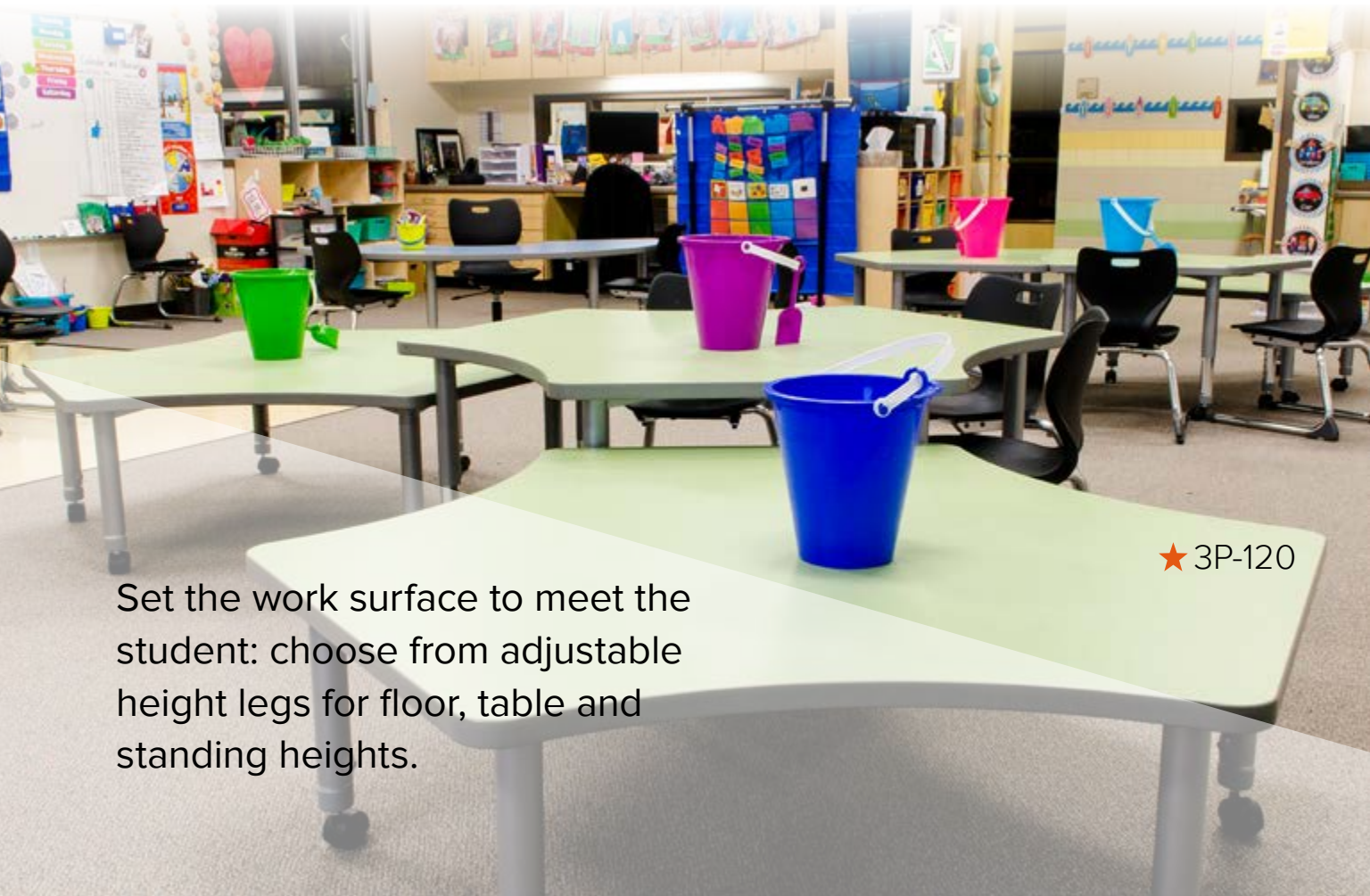

Set the work surface to meet the student: choose from adjustable height legs for floor, table and standing heights.

★ 3P-120

Half Moon

Model	Size
DTT-HM3672E	36" x 72"

Surface Material: See page 98
 Edge Options: See page 98
 Leg Options: See page 77



Kidney

Model	Size
DTT-KD4872E	48" x 72"

Surface Material: See page 98
 Edge Options: See page 98
 Leg Options: See page 77



4P

4P's 48" x 60" work surface seats up to four people. Just like the name says!

Model	Size
DTT-4P4860E	48" x 60"

Surface Material: See page 98
 Edge Options: See page 98
 Leg Options: See page 77



Puddle

60" work surface that supports up to four people.

Model	Size
DTT-PD60E	60"

Surface Material: See page 98
 Edge Options: See page 98
 Leg Options: See page 77



Chevron

Clever variation on the traditional rectangle; seats up to four. Allows for more intimate classroom setup when used in rows.



*Shown with wheelbarrow style legs

Model	Size
DTT-CV2460E	24" x 60"

Surface Material: See page 98
 Edge Options: See page 98
 Leg Options: See page 77

Crescent

Classic Crescent shape offers generous workspace for small groups of two or three or group several together for more options.



Model	Size
DTT-CR3042E	30" x 42"

Surface Material: See page 98
 Edge Options: See page 98
 Leg Options: See page 77

Square

Available in three usable sizes.

Model	Size
DTT-SQ36E	36" X 36"
DTT-SQ42E	42" X 42"
DTT-SQ48E	48" X 48"

Surface Material: See page 98
 Edge Options: See page 98
 Leg Options: See page 77



Star

60" work surface that supports up to five people with all their supplies. Requires five post legs, specified separately.

Model	Size
DTT-ST60E	60"

Surface Material: See page 98
 Edge Options: See page 98
 Leg Options: See page 77



Horseshoe

Model	Size
DTT-HS6066E	60" x 66"

Surface Material: See page 98
 Edge Options: See page 98
 Leg Options: See page 77



Shape Tables | Legs + Casters

Choose the right legs for your tables. Available in Titanium or Black. Add casters for mobility!

Model	Description
DTLP-4AJP	Juvenile height leg kit, adjustable 13"-18"
DTLP-4ATP	Table height leg kit, adjustable 19"-29"
DTLP-4ASP	Standing height leg kit, adjustable 27"-42"
TA-CPS4	50mm black casters, 4pk

Learn more at artcobell.com

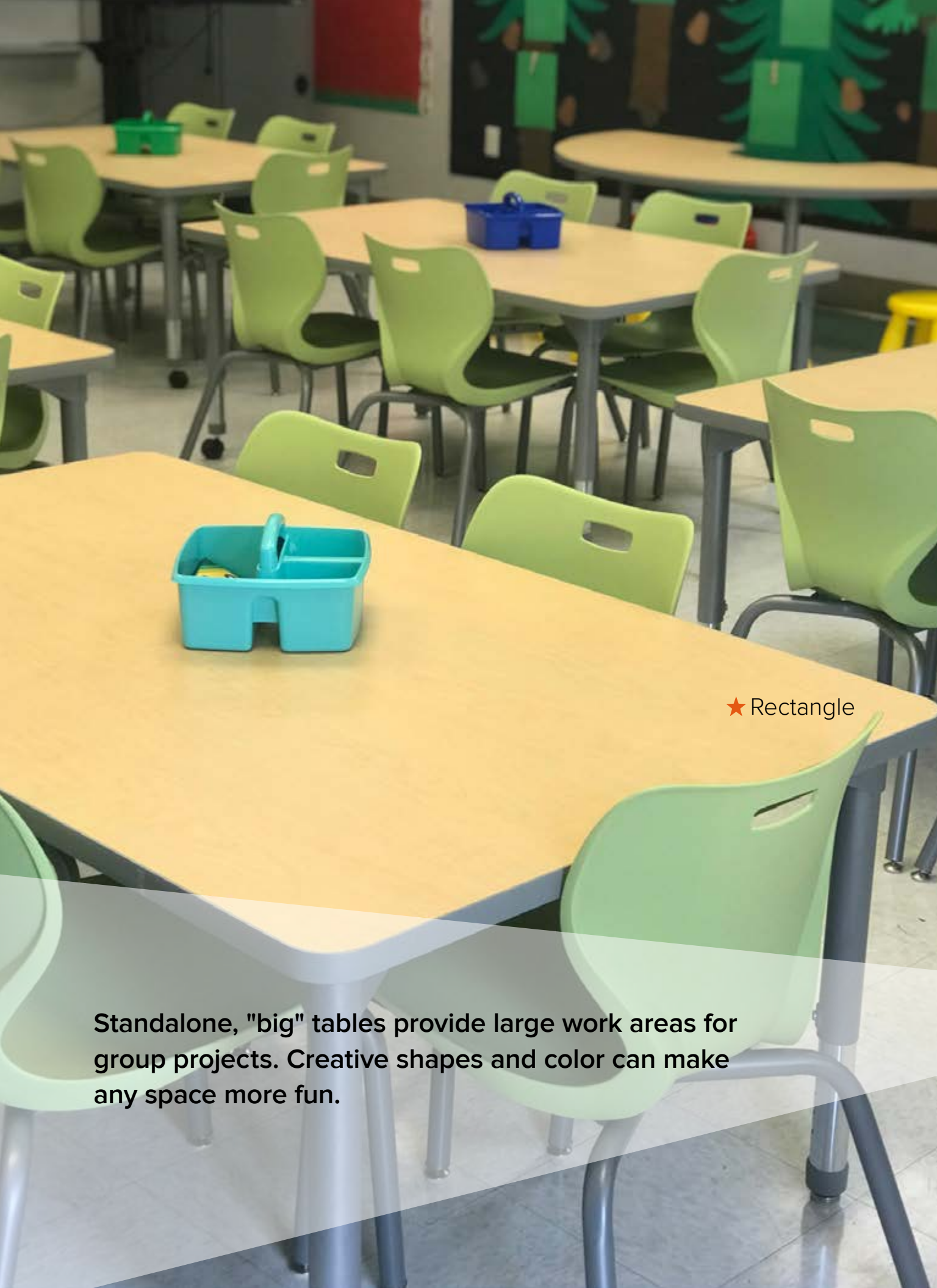

★ Rectangle

Standalone, "big" tables provide large work areas for group projects. Creative shapes and color can make any space more fun.

Rectangle

A variety of widths and lengths to meet a variety of needs.

Model	Size
DTT-RC2448E	24" x 48"
DTT-RC2460E	24" x 60"
DTT-RC2472E	24" x 72"
DTT-RC3048E	30" x 48"
DTT-RC3060E	30" x 60"
DTT-RC3072E	30" x 72"
DTT-RC3660E	36" x 60"
DTT-RC3672E	36" x 72"

Surface Material: See page 98

Edge Options: See page 98

Leg Options: See page 77



Round

Available in four diameter sizes.

Model	Size
DTT-RD36E	36"
DTT-RD42E	42"
DTT-RD48E	48"
DTT-RD60E	60"

Surface Material: See page 98

Edge Options: See page 98

Leg Options: See page 77



Half-Round

Traditional and versatile: pair Half-Rounds, Squares and Rectangles to seat larger groups.

Model	Size
DTT-HR48E	48"

Surface Material: See page 98

Edge Options: See page 98

Leg Options: See page 77





★ Multi-Media

Multi-Media

Can be used with four post legs or combined with cafe base for a variety of looks. Additional accessories make this even more "media friendly".

Model	Size
DTT-MM4872E	48" x 72"

Surface Material: See page 98
 Edge Options: See page 98
 Leg Options: See page 77



Mixed media. Make it work for you.
 ... use legs or bases, or a combination of both
 ... add grommets



★ Multi-Media

Hard-working over-achievers, these T-Leg Tables offer durable work surfaces when you need them, then flip and nest when you don't. Add markerboard laminate to the surface and even the vertical surface can work for you!

Chevron | Nesting

Fixed height nesting table allows students to lean in to work. Standard in 29" height; 25" and 27" heights available.



Model	Size	Leg Type Height
DTN-CV25	24"d x 60"w	Nesting, 29" Fixed
*DTN7CV25	24"d x 60"w	Nesting, 27" Fixed
*DTN5CV25	24"d x 60"w	Nesting, 25" Fixed

Surface Material: See page 98
 Edge Options: See page 98
 * extended lead times and premium may apply

Expanse | Nesting

Fixed height nesting table with a creative wave shape. Standard in 29" height; 25" and 27" heights available.



Model	Size	Leg Type Height
DTN-EX34F	30"d x 54"w	Nesting, 29" Fixed
*DTN7EX34F	30"d x 54"w	Nesting, 27" Fixed
*DTN5EX34F	30"d x 54"w	Nesting, 25" Fixed

Surface Material: See page 98
 Edge Options: See page 98
 * extended lead times and premium may apply



Rectangle | Nesting

Fixed height nesting tables available in a variety of lengths and widths. Standard in 29" height; 25" and 27" heights available.

Model	Size	Leg Type Height
DTN-RC24F	24"d x 54"w	Nesting, 29" Fixed
DTN-RC25F	24"d x 60"w	Nesting, 29" Fixed
DTN-RC26F	24"d x 72"w	Nesting, 29" Fixed
*DTN7RC24F	24"d x 54"w	Nesting, 27" Fixed
*DTN7RC25F	24"d x 60"w	Nesting, 27" Fixed
*DTN7RC26F	24"d x 72"w	Nesting, 27" Fixed
*DTN5RC24F	24"d x 54"w	Nesting, 25" Fixed
*DTN5RC25F	24"d x 60"w	Nesting, 25" Fixed
*DTN5RC26F	24"d x 72"w	Nesting, 25" Fixed
DTN-RC34F	30"d x 54"w	Nesting, 29" Fixed
DTN-RC35F	30"d x 60"w	Nesting, 29" Fixed
DTN-RC36F	30"d x 72"w	Nesting, 29" Fixed
*DTN7RC34F	30"d x 54"w	Nesting, 27" Fixed
*DTN7RC35F	30"d x 60"w	Nesting, 27" Fixed
*DTN7RC36F	30"d x 72"w	Nesting, 27" Fixed
*DTN5RC34F	30"d x 54"w	Nesting, 25" Fixed
*DTN5RC35F	30"d x 60"w	Nesting, 25" Fixed
*DTN5RC36F	30"d x 72"w	Nesting, 25" Fixed

Surface Material: See page 98
 Edge Options: See page 98
 * extended lead times and premium may apply



Half Round | Fixed Top

Available in two sizes.

Model	Size	Leg Type Height
DTF-HR48F	32"d x 48"w	29" Fixed
*DTF7HR48F	32"d x 48"w	27" Fixed
*DTF5HR48F	32"d x 48"w	25" Fixed
DTF-HR60F	30"d x 60"w	29" Fixed
*DTF7HR60F	30"d x 60"w	27" Fixed
*DTF5HR60F	30"d x 60"w	25" Fixed

Surface Material: See page 98
 Edge Options: See page 98
 * extended lead times and premium may apply



Learning without boundaries starts with a place for exploration. Heavy-duty Makerspace Tables can be configured with tops, shelves and end-panels to carry whatever meets learning needs, from play to real work.



Makerspace Table Top

Pick the top that best suits your needs: durable, hard-wearing high pressure laminate with a variety of colorful edge band options, or chemical-resistant epoxy for more specialized makerspace projects.



Model	Dimensions	Top Description
DTMT-RC2448F	24" x 48"	1 1/8" Laminate
DTMT-RC2454F	24" x 54"	1 1/8" Laminate
DTMT-RC2460F	24" x 60"	1 1/8" Laminate
DTMT-RC2472F	24" x 72"	1 1/8" Laminate
DTMT-RC3060F	30" x 60"	1 1/8" Laminate
DTMT-RC3072F	30" x 72"	1 1/8" Laminate
DTMT-RC3672F	36" x 72"	1 1/8" Laminate
DTMT-RC2448Y	24" x 48"	Epoxy
DTMT-RC2454Y	24" x 54"	Epoxy
DTMT-RC2460Y	24" x 60"	Epoxy
DTMT-RC2472Y	24" x 72"	Epoxy
DTMT-RC3060Y	30" x 60"	Epoxy
DTMT-RC3072Y	30" x 72"	Epoxy
DTMT-RC3672Y	36" x 72"	Epoxy

Surface Material: See page 98

Edge Options: See page 98

Makerspace Frame

Heavy duty, fully-welded frame. Sturdy optional casters (TA-CPTD3) available.

Model	Size	Height
DTMF-RC2448S	24" x 48"	Adjustable 25" - 42"
DTMF-RC2454S	24" x 54"	Adjustable 25" - 42"
DTMF-RC2460S	24" x 60"	Adjustable 25" - 42"
DTMF-RC2472S	24" x 72"	Adjustable 25" - 42"
DTMF-RC3060S	30" x 60"	Adjustable 25" - 42"
DTMF-RC3072S	30" x 72"	Adjustable 25" - 42"
DTMF-RC3672S	36" x 72"	Adjustable 25" - 42"

Glide: Nylon (3), Steel (1)

Frame Color: Black (7), Titanium (4)

Shelf Kit: See page 87

Makerspace | Accessories

Add more functionality to Makerspace tables and cabinets.

Table End Panels	MSTA-EP	Metal pegboard, 20" high, 24", 30" and 36" widths
Table Shelves	MSTA-SL	48", 54", 60", 72" lengths; 12" and 16" depths, Titanium or Black
Table Casters	TA-CPTD3	Locking 75mm
Totes & Shelves	MSCA-TK	Tote Tray Translucent, 12" depth, 3", 6", 12" depths
	MSCA-SK1216.W	Acrylic Markerboard/Shelf, 12"x16"
Cabinet Door Kit	MSCA-DK230T	2-Column, 30"h
	MSCA-DK242T	2-Column, 42"h
	MSCA-DK342T	3-Column, 42"h



Multipurpose (Catalyst)

Full metal frame, lighter-weight alternative to our heavy-duty Makerspace Tables. Add casters (TA-CPTD3) for extra mobility.



Model	Size	Leg Type Height
DTMA2448F	24"d x 48"w	Adjustable 25" - 34"
DTMA2454F	24"d x 54"w	Adjustable 25" - 34"
DTMA2460F	24"d x 60"w	Adjustable 25" - 34"
DTMA2472F	24"d x 72"w	Adjustable 25" - 34"
DTMA3060F	30"d x 60"w	Adjustable 25" - 34"
DTMA3072F	30"d x 72"w	Adjustable 25" - 34"
DTMA3672F	36"d x 72"w	Adjustable 25" - 34"

Frame Color: Black (7), Titanium (4)

Surface Material: See page 98

Edge Options: See page 98



★ Catalyst



★ Catalyst



Classic Table tops can be combined with Cafe Bases in two heights for lounge spaces, media centers and walk-up sharing.

Square

Model	Size
DCT-SQ30F	30"
DCT-SQ36F	36"

Surface Material: See page 98
Edge Options: See page 98



Round

Model	Size
DCT-RD30F	30"
DCT-RD36F	36"
DCT-RD42F	42"

Surface Material: See page 98
Edge Options: See page 98



Racetrack

Model	Size
DCT-RT3372F	33" x 72"

Surface Material: See page 98
Edge Options: See page 98



Cafe Tables | Bases

Available in Titanium.

Model	Description
DCBR-1830.4	18" diameter x 30" height
DCBR-2430.4	24" diameter x 30" height
DCBR-1842.4	18" diameter x 42" height
DCBR-2442.4	24" diameter x 42" height

Activity tables are ideal for impromptu gatherings in the library, private one-on-one sessions in the classroom, or larger team meetings in the conference room.



★ Kidney

Kidney

Model	Size	Leg Type Height
1275F	48" x 72"	Adjustable 21" - 29"

Glide: Nylon (3)
 Leg Color: Black (7), Titanium (4)
 Surface Material: See page 98
 Edge Options: See page 98



Half Round

Model	Size	Leg Type Height
1285F	48"	Adjustable 21" - 29"

Glide: Nylon (3)
 Leg Color: Black (7), Titanium (4)
 Surface Material: See page 98
 Edge Options: See page 98



Horseshoe

Model	Size	Leg Type Height
1277F	60" x 66"	Adjustable 21" - 29"

Glide: Nylon (3)
 Leg Color: Black (7), Titanium (4)
 Surface Material: See page 98
 Edge Options: See page 98



Round

Model	Size	Leg Type Height
1281F	42"	Adjustable 21" - 29"
1280F	48"	Adjustable 21" - 29"

Glide: Nylon (3)
 Leg Color: Black (7), Titanium (4)
 Surface Material: See page 98
 Edge Options: See page 98



Rectangle



Model	Size	Leg Type Height
1206F	24" x 36"	Adjustable 21" - 29"
1210F	24" x 48"	Adjustable 21" - 29"
1235F	24" x 60"	Adjustable 21" - 29"
1246F	24" x 72"	Adjustable 21" - 29"
1220F	30" x 48"	Adjustable 21" - 29"
1230F	30" x 60"	Adjustable 21" - 29"
1250F	30" x 72"	Adjustable 21" - 29"
1240F	36" x 60"	Adjustable 21" - 29"
1260F	36" x 72"	Adjustable 21" - 29"

Glide: Nylon (3)
 Leg Color: Black (7), Titanium (4)
 Surface Material: See page 98
 Edge Options: See page 98

Square

Model	Size	Leg Type Height
1205F	36" x 36"	Adjustable 21" - 29"
1215F	42" x 42"	Adjustable 21" - 29"
1225F	48" x 48"	Adjustable 21" - 29"

Glide: Nylon (3)
 Leg Color: Black (7), Titanium (4)
 Surface Material: See page 98
 Edge Options: See page 98



Trapezoid

Model	Size	Leg Type Height
1290F	30" x 60"	Adjustable 21" - 29"

Glide: Nylon (3)
 Leg Color: Black (7), Titanium (4)
 Surface Material: See page 98
 Edge Options: See page 98



Rectangle ★



Clover

Model	Size	Leg Type Height
128CF	48"	Adjustable 21" - 29"

Glide: Nylon (3)
 Leg Color: Black (7), Titanium (4)
 Surface Material: See page 98
 Edge Options: See page 98



Flower

Model	Size	Leg Type Height
128FF	60"	Adjustable 21" - 29"

Glide: Nylon (3)
 Leg Color: Black (7), Titanium (4)
 Surface Material: See page 98
 Edge Options: See page 98





Computer Tables

The CY series table works wherever you need a sturdy technology-ready worktop. Wire management tray/modesty panel keeps cables organized (12" depth for 24"-wide tables; 16" depth for 30"-wide tables). Installed grommets: (1) for 36" and 48"-lengths; (2) for 60" and 72" lengths.

Model	Size
CY13F	24" x 36"
CY14F	24" x 48"
CY15F	24" x 60"
CY16F	24" x 72"
CY03F	30" x 36"
CY04F	30" x 48"
CY05F	30" x 60"
CY06F	30" x 72"

Glide/Caster: Nylon (3), Casters (8)
 Frame Color: Black (7), Titanium (4)
 Surface Material: See page 98
 Edge Options: See page 98



Convertible Bench Table

Flexibility is redefined by a convertible bench unit that can easily fold from a lunch table to a back support bench. This allows you to quickly reconfigure your space for testing, study or events. When folded, the units can be nested creating a compact storage solution to maximize your available storage capacity.

Model	Size	Bench Height
ABC89PN	8'w x 29"h	17"

Frame Color: Titanium (4), Black (7)
 Surface Material: See page 98
 Bench Material: See page 98
 Edge Options: Permatuff (N)



Bench ★
Position

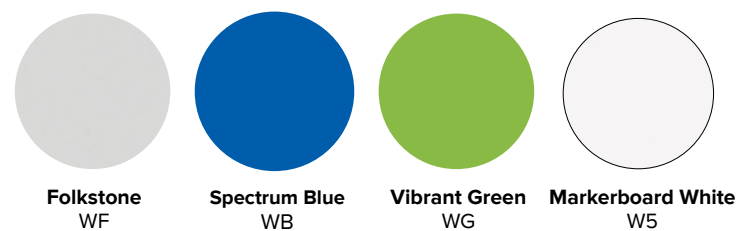

Table ★
Position

Standard Laminates



Premium Markerboard Laminates



Edge Band

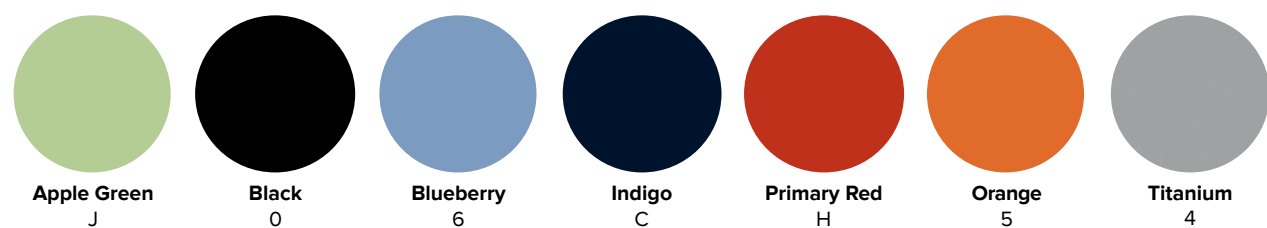

Additional designs available: Most Wilsonart® Laminates are available as special orders. Minimum quantities and extended lead times will apply. Any laminate design that is **not** part of the Artcobell collection shown here will be priced as **premium**.



TEACHER WORKSTATIONS

Learning without boundaries spawns imagination.

ADAPTABLE
PERSONALIZED
MOBILE
SIT. STAND. STORE.
INTERACTIVE
ENGAGED



Page 88

Catalyst Tables

Sometimes your workstation isn't stationary at all. **artcobell** offers two solutions that let you move up and down and around to where your students are.



ARISE Podium

Podium or work station? ARISE moves with you with infinite stop, adjustable height and casters that let you move to where the action is.

Model	Size	Height
ATPA1F	24" x 36" Top	Adjustable 30.5" - 50"

Frame Color: Titanium (4)
 Surface Material: See page 106
 Edge Options: See page 106
 Accessories: See page 104



Sit-to-Stand Desk

The next generation in flexible desks. Sit-to-Stand is fully adjustable from 28" to 41" and moves easily around a room or room-to-room. Roomy work surface and elegant base design allows for one or two users.

Model	Size	Top Material Edge	Height
STS-RC2228E	22"x28"	Laminate Edge Band	Adjustable 28"-41"

Frame Color: Titanium (4)
 Surface Material: See page 64
 Edge Options: See page 64

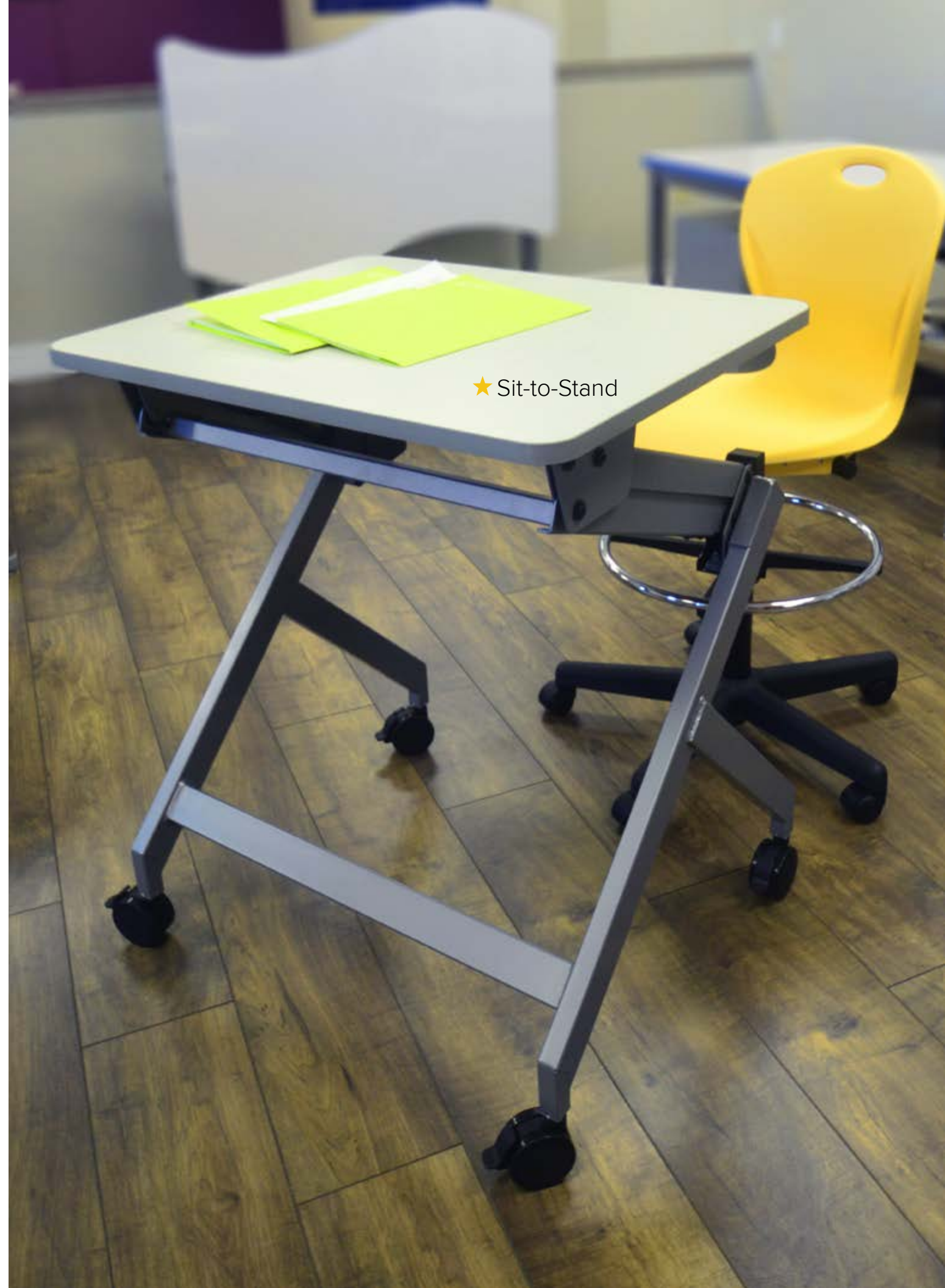

Our Single Pedestal Teacher Desk is a mobile solution that doesn't compromise on storage. Three different top shapes in a variety of sizes feature durable high pressure laminate with your choice of coordinating edge banding. All feature a castered T-leg and mobile pedestal and a variety of accessories.

Discover Teacher Desk

Model	Size	Top Shape
DTDT-RC2448F	24"d x 48"w	Rectangle
DTDT-RC2460F	24"d x 60"w	Rectangle
DTDT-RC2472F	24"d x 72"w	Rectangle
DTDT-RC3048F	30"d x 48"w	Rectangle
DTDT-RC3060F	30"d x 60"w	Rectangle
DTDT-RC3072F	30"d x 72"w	Rectangle
DTDT-D3060F	30"d x 60"w	D-Shape
DTDT-D3072F	30"d x 72"w	D-Shape
DTDT-PR3072F	30"d x 72"w	P-Shape
DTDT-PL3072F	30"d x 72"w	P-Shape

Surface Material: See page 106
Edge Options: See page 106



*DTDT-D3060F shown above

Teacher's Desk | Accessories

Add more functionality to your workstation.

Legs	DTLK-1TF29C.4	T-Leg with Casters, Titanium
Pedestal	DPF-BBFR.L.4	Supporting Pedestal, Box/Box/File
Drawer	TA-CD.4	Center Drawer, 17.26"h x 21.25"w x 3"d, Titanium
Screens	TA-SA1224.F	Privacy Screen, 12"h x 24"w
	TA-SA1236.F	Privacy Screen, 12"h x 36"w
	TA-SA1248.F	Privacy Screen, 12"h x 48"w
Grommet	TA-GR3	3" Round, Black Only

D400

Single pedestal, height adjustable teachers' desk with center drawer.

Model	Size	Description
D4R0HF	30"d x 48"w	Single Pedestal, RH, Center Drawer
D4L0HF	30"d x 48"w	Single Pedestal, LH, Center Drawer

Glide/Caster: Nylon (3)
Frame Color: Black (7)
Surface Material: See page 106
Edge Options: See page 106



*D500 shown above

D500

Our classic height adjustable teacher desk. Double pedestal with center drawer.

Model	Size	Description
D500HF	30"d x 60"w	Double Pedestal, Center Drawer

Glide/Caster: Nylon (3)
Frame Color: Black (7)
Surface Material: See page 106
Edge Options: See page 106



★ Discover Teacher Desk

Standard Laminates



Premium Markerboard Laminates

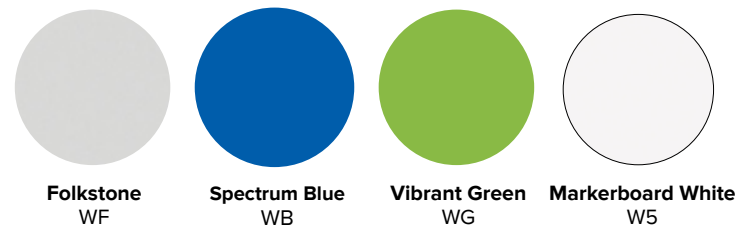

Edge Band

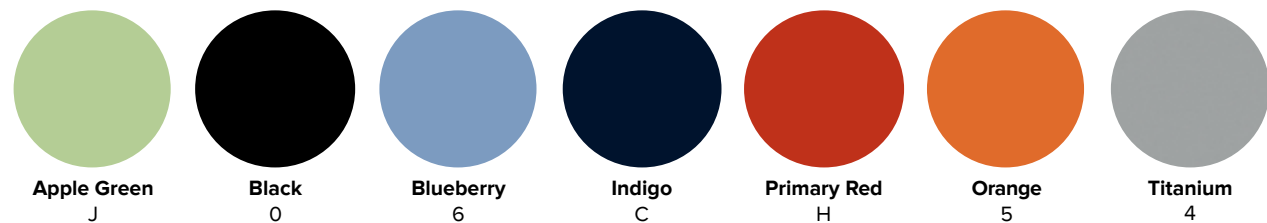

Additional designs available: Most Wilsonart® Laminates are available as special orders. Minimum quantities and extended lead times will apply. Any laminate design that is **not** part of the Artcobell collection shown here will be priced as **premium**.



★ Half Moon Shape Table

STORAGE

Learning without boundaries provides easy access to materials and resources.

FLEXIBLE
ORGANIZED
MOBILE
MULTI-FUNCTIONAL
DURABLE
MIX+MATCH
CONFIGURABLE



Storage that's mobile, flexible and built of heavy-duty steel. Cabinets with rails can be expanded with separate lockable doors, three sizes of trays and a shelving option that can also move between cabinets and desks. Cabinets with shelves feature sturdy, built in metal cubbies. Both options comes with pre-drilled hole for installing charging/power grommet.



2-Column With Rails, 42"h

Meets up with stand-height (42") tables or mobile bookcases. Holds (18) 3" trays or mix/match 3" and 6" trays for tailored storage.

Model	Description
MSC-242PX.4.W	Pegboard End Panel, w/Rails

Tray Kits: See page 87
 Door Kit: See page 87
 Accessories: See page 87

2-Column With Rails, 30"h

Ideal small storage solution for younger grades or small spaces. Holds (12) 3" trays or (6) 6" trays.

Model	Description
MSC-230PX.4.W	Pegboard End Panel, w/Rails

Tray Kits: See page 87
 Door Kit: See page 87
 Accessories: See page 87



2-Column With Cubbies, 42"h

Meets up with stand-height (42") tables or mobile bookcases. Six 10.5" tall x 12" wide cubbies hold backpacks, shoes, lunchboxes, and more.

Model	Description
MSC-242PC.4.W	Pegboard End Panel, w/Cubbies

Tray Kits: See page 87
 Door Kit: See page 87
 Accessories: See page 87



3-Column With Rails, 42"h

Meets up with stand-height (42") tables or mobile bookcases. Holds (27) 3" trays or mix/match 3" and 6" trays for tailored storage.

Model	Description
MSC-342PX.4.W	Pegboard End Panel, w/Rails

Tray Kits: See page 87
 Door Kit: See page 87
 Accessories: See page 87



3-Column With Cubbies, 42"h

Meets up with stand-height (42") tables or mobile bookcases. Nine 10.5" tall x 12" wide cubbies hold backpacks, shoes, lunchboxes, and more.

Model	Description
MSC-342PC.4.W	Pegboard End Panel, w/Cubbies

Tray Kits: See page 87
 Door Kit: See page 87
 Accessories: See page 87



Roll this cabinet to where the fun is taking place - even from room to room! Shown with optional locking door kit.

Versatile mobile shelves feature both single and double shelf faces and sturdy casters. Strong magnets at the ends allow you to link cabinets together to organize both space and storage.



Single Face Radius Shelves

Model	Size	Description
ASFVSC-1742F	42"h x 60"w x 17"d	Flat Panel
ASFVSC-1742P	42"h x 60"w x 17"d	Perforated Panel

Surface Material: See page 117



Double Face Radius Shelves

Model	Size	Description
ADFVSC-2042F	42"h x 60"w x 20"d	Flat Panel
ADFVSC-2042P	42"h x 60"w x 20"d	Perforated Panel

Surface Material: See page 117



Single Face Linear Shelves

Model	Size	Description
ASFVS-1742F	42"h x 42"w x 17"d	Flat Panel
ASFVS-1742P	42"h x 42"w x 17"d	Perforated Panel

Surface Material: See page 117



Double Face Linear Shelves

Model	Size	Description
ADFVS-2042F	42"h x 42"w x 20"d	Flat Panel
ADFVS-2042P	42"h x 42"w x 20"d	Perforated Panel

Surface Material: See page 117



Translucent Tote Trays + Markerboard Shelves work with Mobile Storage Cabinets too.



Combine Single Face Mobile Cabinets with 42" Makerspace Cabinets - the magnets hold everything together!



★ Mix + Match!

Book Shelves

Practical and versatile, thermofused laminate-clad bookcases are 12" deep, 37.25" wide and come in 36", 48", 60" and 72" heights. Choose from popular and classic designs to coordinate with the rest of your Artcobell classroom furniture.



Model	Size
A1236MBC	36"h x 37 1/4"w x 12"d



A1248MBC	48"h x 37 1/4"w x 12"d
----------	------------------------



A1260MBC	60"h x 37 1/4"w x 12"d
----------	------------------------



A1272MBC	72"h x 37 1/4"w x 12"d
----------	------------------------

Surface Material: See page 117





★ Mix + Match
Mobile Cabinets

Standard Laminates (Mobile Cabinets, Bookshelves)



Standard Laminates (Makerspace Door Kit)



Premium Markerboard Laminates (Makerspace Door Kit)

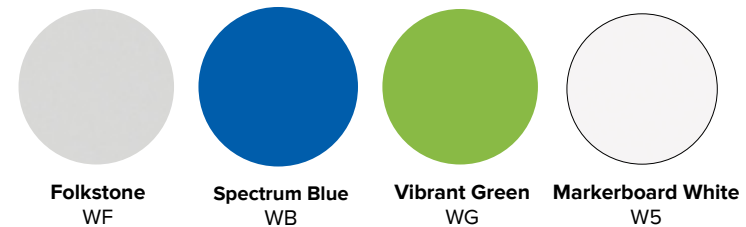

Learn more at artcobell.com



PICTURE BOOKS

Mystery

W L S P E



1.1.2020
ABC CATALOG 20

artcobell

www.artcobell.com
1.877.778.1811

6.22.20 • v3

PRICER

ADAPTABLE SOLUTIONS
FOR LEARNING WITHOUT
BOUNDARIES



artcobell

CONTENT

TERMS & CONDITIONS	3
PRODUCT INFO	5
SOFT SEATING	6
SEATING	17
STUDENT DESKS	45
TABLES	62
TEACHER WORKSTATIONS	81
STORAGE	89
PROJECT	96
WARRANTY	117

* Makerspace Tables can now be found in the Tables section.

* Makerspace Cabinets can now be found in the Storage section

Authorized Dealers: Only dealers (“Dealer”) that have been approved by Artcobell Corporation (“ABC”), and are in good standing with ABC are authorized to market, provide pricing, and submit orders for ABC products. By engaging in business transactions with ABC, Dealers agree to the current ABC terms and conditions.

Pricing: All pricing provided by ABC to Dealers is based on the current list price and excludes taxes, freight, delivery, and installation. Except as stated in a quote number issued by ABC, any discount ABC offers a Dealer will be from current list price at the standard dealer discount. In order to obtain the discount in an issued quote number, Dealer must provide the quote number, discount and pricing at the time it submits a purchase order. If the correct quote number and pricing are not provided, the Dealer will receive its standard dealer discount.

Payment Terms: ABC will invoice Dealer for product upon shipment. Dealer agrees to pay each invoice according to terms. Dealer terms will be determined by Artcobell through credit analysis. Certain Dealers may qualify for 1% 10 Net 30 days from the invoice date. Payment must be received by bank within 10 days of invoice date to receive the 1% discount. Credit card payment terms are net 30. No payment may be withheld because of partial delivery. Dealer will pay interest on any unpaid amount due at the lower of 1.5% per month or the highest rate allowed by law. If ABC takes any action to collect any amount due, Dealer will pay all costs and expenses, including court costs and reasonable attorney fees, incurred by ABC in collecting such amount.

Order Placement and Acknowledgments: Dealers will submit all orders with complete model number (i.e., color, frame, material, finish), and for product that must be shipped in cartons, carton quantity. ABC will not process or put into production an order without complete information. Lead time will be calculated based on the time the order is processed. After an order is processed, ABC will acknowledge the order via email or fax. Acknowledgments provided by ABC represent estimated completion dates and are not contractually binding. Any expenses incurred as a result of longer lead times will be the responsibility of the dealer. Dealer is responsible for checking the acknowledgment and immediately notifying ABC of any discrepancies.

Changes and Cancellations: Changes requested by Dealer after ABC has acknowledged the order must be sent in writing and are subject to written approval by ABC and additional charges. If ABC approves in writing any request by Dealer to cancel all or any part of an order after 48 hours from time of acknowledgment, dealer agrees to pay 25% cancellation fee.

Returns: Product will not be returned for refund, credit, or replacement, except on written approval by ABC. If approved by ABC, dealer agrees to pay a restocking fee determined by ABC and any associated freight charges.

Delays: ABC will not be liable for any delay or interruption in its performance caused by circumstances beyond its reasonable control, including, without limitation, strikes, lockouts, work stoppages, accidents, terrorism, and availability of materials, acts of nature or God, inability to obtain transportation, or acts of the enemy. Delays so caused will not release Dealer from its obligation to accept and pay for the product.

Storage: Products that are complete and ready must be shipped within 30 days of original request date otherwise subject to storage fees.

Delivery and Installation: All shipments are F.O.B. ABC’s factory or distribution center. Delivery is always quoted to take place during ABC’s regular working hours on ABC’s regularly scheduled business days (holidays excluded). Dealer will pay additional labor costs resulting from overtime work performed at Dealer’s request. Dealer is responsible for providing: a clean, debris-free space with electricity, heat, hoisting/elevator service, and adequate facilities for off-loading, staging, uncartoning, and moving product; insurance and permits required at the site; and disposal containers. Delivery does not include the following additional expenses, which are the responsibility of Dealer: providing a licensed electrician, as required by national or local codes, to connect products to building power. If the space is under construction or other trades are working in the same space during the product installation, Dealer will immediately inspect the product on delivery for defects. If Dealer or Dealer’s customer is not available to inspect product on delivery, then Dealer and Dealer’s customer accept that all product was delivered in satisfactory condition and Dealer accepts all responsibility for any damages found later.

Loss and Damages: After delivery of product to Dealer’s shipper or, if ABC is arranging freight, after delivery to shipping address, all risk of loss or damage shall pass to Dealer, including, without limitation, any loss or damage caused by weather, other trades (such as painting or plastering, electrical or telephone installation), fire or other elements, and Dealer agrees to hold ABC harmless from any such loss or damage.

Warranties: Dealer’s remedies are limited exclusively to those set forth in ABC’s standard limited warranty as published at www.artcobell.com at the time of delivery of the product to carrier. ABC MAKES NO WARRANTY, EXPRESS OR IMPLIED, WITH RESPECT TO ANY PRODUCT OR SERVICE FURNISHED TO DEALER, AND ANY IMPLIED WARRANTIES OF MERCHANTABILITY OR FITNESS FOR A PARTICULAR PURPOSE ARE EXPRESSLY DISCLAIMED BY ABC. No agent or outside party has any authority to make

any warranty or representation to Dealer on behalf of ABC with respect to any product or service provided to Dealer by ABC. In no event will Artcobell be liable for any consequential, indirect, incidental, or punitive damages. Modifications to the product or use other than the intended purpose voids the warranty.

Shipment Terms: All orders shall be shipped prepaid and, unless specified, by ABC's carrier of choice. "Best way" shipping will be used. Pricing on shipments is an estimate and may vary by special charges incurred due to the consignee. These are estimates and additional charges are the responsibility of the Dealer.

LTL shipments are dock-to-dock at Dealer's expense. Any special delivery considerations are the responsibility of the consignee. This includes any accessorial charges billed by the carrier. LTL shipments may also be subject to a packaging surcharge.

Delivery dates are the responsibility of the carrier unless otherwise agreed to between Artcobell Corporation and the consignee. No expenses will be incurred by Artcobell Corporation for missed delivery appointments. Delivery scheduling is to be handled between the dealer and the carrier. All expenses incurred due to detention or other factors, caused by the consignee, shall be the responsibility of the dealer. If the delivery location is not ready for receipt of a shipment, all charges incurred by the freight company will be passed on to the dealer. If the shipment returns to Artcobell Corporation, the costs for handling and restocking will be billed back to the dealer, along with an administrative fee of 5% of the order total.

Dealer arranged van shipments will be assessed a service fee of \$150.

If a "live load" appointment is missed by more than 2 hours or the driver arrives after 2:00pm, a missed appointment fee of \$250 will be assessed to the Dealer. The carrier will not be guaranteed immediate attention if a live load appointment is missed, and the load may need to be rescheduled. Shipments outside of the continental U.S. are to be pre-arranged by the dealer.

Shipment Damages: Artcobell will not be responsible for freight damage on prepaid shipments when items are shipped via small parcel (USPS, UPS, Fed Ex, etc.).

Any freight damage, truckload or LTL, MUST be notated on the POD (proof of delivery) or reported within 5 days of delivery in order to qualify for a no cost replacement from Artcobell. All shipments should be carefully inspected at the time of delivery by the consignee. Any damages are to be noted on the bill of lading at the time of delivery. Concealed damage must be reported within 15 days of receipt of shipment. Damaged freight must be held at the point of delivery, along with original packaging to be considered for a claim. Digital photos are required and will speed up the claims process. Shipments left unopened for a period of more than 15 days will not be considered for claim or replacement. Shipment liability ceases after 15 days of delivery.

Shipment Shortages: Shortages not reported within 15 days of shipment receipt will not be honored for a claim. Shortages must be noted on the bill of lading at the time of delivery and reported to Artcobell within 15 days for consideration. Claims for shortages will not be approved if ABC has a "scan sheet" confirming all products were loaded.

Dealer's and User's Care and Use Instructions: Products are to be used for their intended purpose and inspected on a regular basis to avoid structural failures and possible injury. Inspections are to include verifying there are no loose or missing screws, rivets, or other fasteners. Products are to be inspected for cracks, fatigue, or broken welds. Products that have adjustability are to be inspected to ensure the fasteners are installed and adjusted properly. Any product showing signs of damage or improper adjustment must be removed from service immediately and notice must be promptly provided to ABC and the furnishing dealer. Repairs are to be made with factory authorized parts and methods.

Other: Questions about invoices must be communicated to ABC within 15 days of the invoice date. These Terms and Conditions may be changed by ABC without notice and are the only terms and conditions which apply to ABC's products. These Terms and Conditions are governed by Texas law, without regard to its conflicts of laws provisions. In the event of a dispute, the non-prevailing party will pay the prevailing party's reasonable attorneys' fees.

* Product line, prices, discounts, payment terms, and other terms and conditions applicable to the sale of products to the Dealer are subject to change by Artcobell without notice.

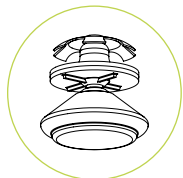

Nylon (3)
All purpose nylon swivel glide
Rounded leading edge
VCT, Vinyl, Tile or Carpet flooring

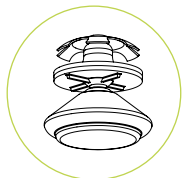

Steel (1)
All purpose steel swivel glide
Best glide for carpeted surfaces

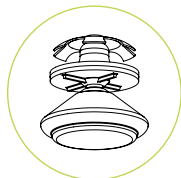

Non Skid (2)
All purpose non-skid swivel glide
Not for use on carpeted surfaces

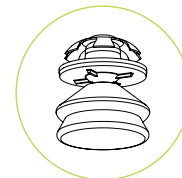

Felt (F)
All purpose felt swivel glide
VCT, Vinyl, Tile or Wood.
Glide cap can be changed out in seconds

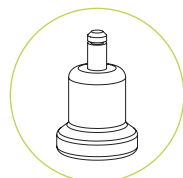

Bell Glide (B)
For use on 5-star task and Stool bases. Nylon base

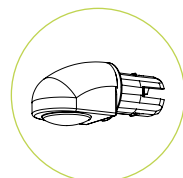

Cantilever Toe Glide
Select from nylon (3), Steel (1)
Felt (F) or Non-skid (2) button
Glide inserts.

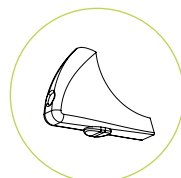

Cantilever Heel Glide
Select from nylon (3), Steel (1)
Felt (F) or Non-skid (2) button
Glide inserts.

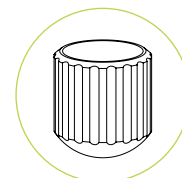

Boot Glide (**)
Non-Skid Rubber
Available in Multiple Colors
VCT, Vinyl or Tile

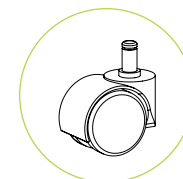

Hard Wheel (H)
50mm Dual Hard Wheel
7/16 x 7/8 brass grip ring

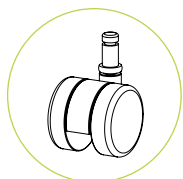

Hard Wheel
50mm Dual Hard Wheel
7/16 x 7/8 brass grip ring
Discover and Uniflex
4-Leg Chairs

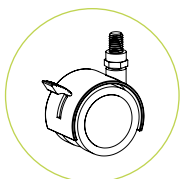

TA-CPS4
50mm Dual Soft Wheel
Locking Caster
3/8" - 16 x 1"
Threaded Stem

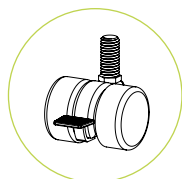

TA-CPS37T4
37 mm Dual Wheel Caster
3/8" - 16 x 1"
Threaded Stem

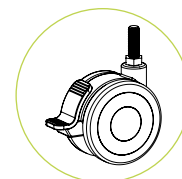

TA-CPTD3
75mm Locking Caster
3/8" - 16 x 1"
Threaded Stem

REFER TO SPECIFIC PRODUCT PAGES FOR GLIDE AVAILABILITY BY MODEL.

NOTE ON GLIDES & FLOOR MAINTENANCE

Our research shows that no single solution can provide optimum performance across all floor types and conditions. Overall performance is based upon the type of flooring, preventative floor maintenance program and glide design & material selection. To maximize the performance of your furniture glides, floors must be properly prepared, and maintained. Soil, grit and the wrong polish can make a floor susceptible to damage regardless of the glides used on your furniture. Your flooring installer and/or manufacturer can provide specific guidelines on floor maintenance.

SOFT SEATING

The latest entry into the Artcobell line focuses on COMFORT and FLEXIBILITY. Clever upholstered shapes, available in easy care fabrics and vinyl, are designed to mix and match in any space. Our sleek new lounge pieces - sofa, love seat and chair - provide good looks and practicality to more public areas and offices.

STATEMENT OF LINE – 7

2-STEP – 10

3-STEP - 10

SQUARE – 10

OTTOMAN – 11

BARREL + BARREL SLANT – 11

ROUND ROCKER – 11

ROUND – 11

CRESCENT – 12

ARC – 12

BENCHES – 13

LEGS/CASTERS – 13

PIXEL – 14

SPOT – 15

PADS – 15

LOUNGE – 16

STATEMENT OF LINE

SOFT SEATING

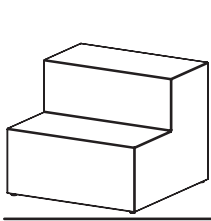

SS-ST230

2-STEP

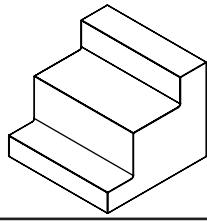

SS-ST330

3-STEP

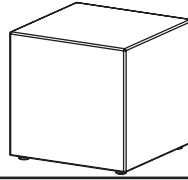

SS-SQ18

Square

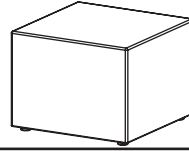

SS-SQ14

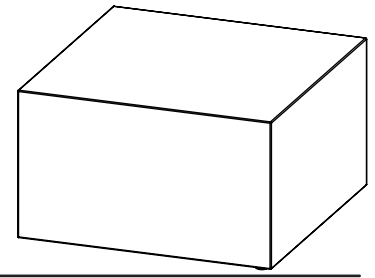

SS-SQ3818

Ottoman | 38" Square

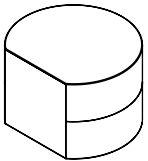

SS-BA12

Barrel

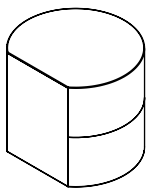

SS-BA16

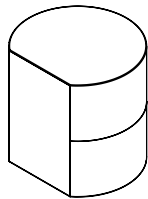

SS-BA18

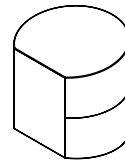

SS-BAS12

Barrel Slant

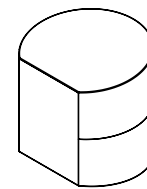

SS-BAS16

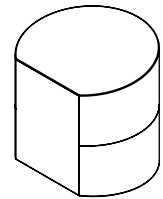

SS-BAS18

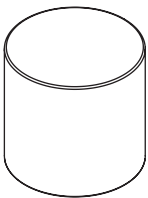

SS-RR18

Round Rocker

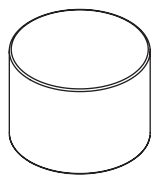

SS-RR14

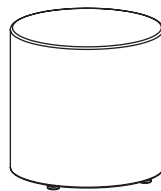

SS-RD18

Round

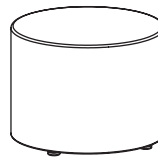

SS-RD14

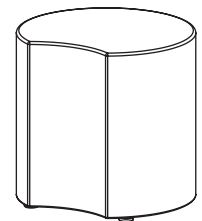

SS-CR18

Crescent

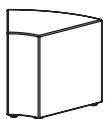

SS-R818

Arcs

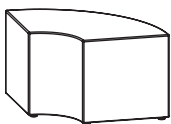

SS-R418

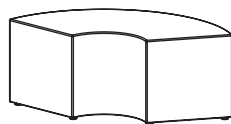

SS-R318

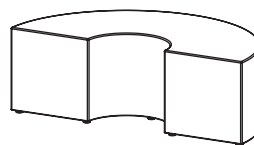

SS-R218

STATEMENT OF LINE

SOFT SEATING



ASPOT16

Spot



ASPXL16.4

Pixel



ASPXL16.R

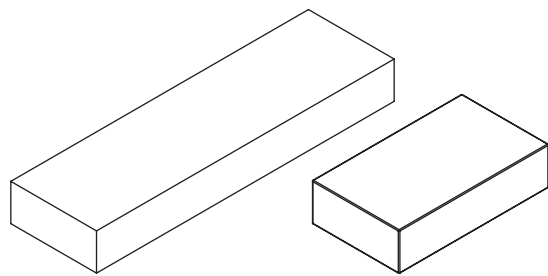

SS-RP4814

SS-RP2414

Pad

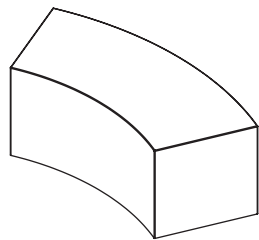

SS-BC18

Curved Bench

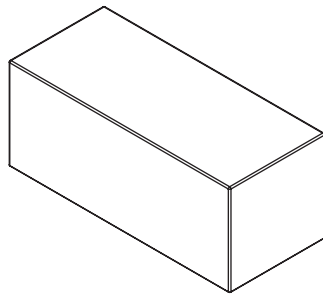

SS-RC1842

Bench

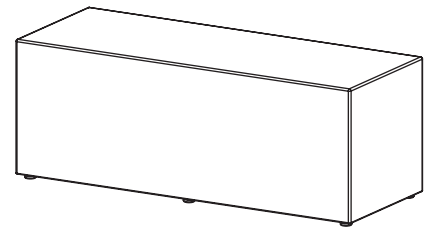

SS-RC1848

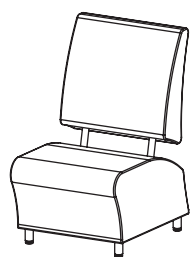

SS-SB24

Lounge

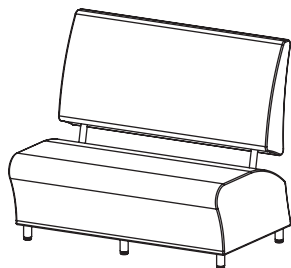

SS-SB48

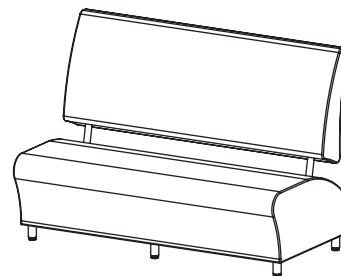

SS-SB60

Standard Soft Seating Colors - Silvertex® Vinyl

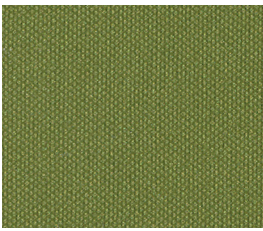

Basil
S02

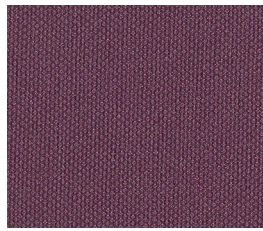

Blackberry
S04



Carbon
S08

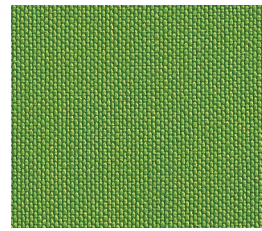

Crème De Menthe
S13

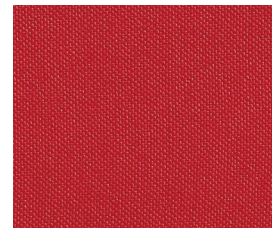

Imperial
S15

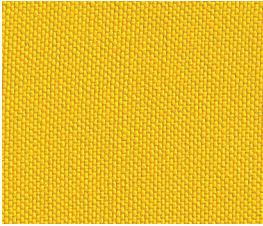

Limoncello
S18

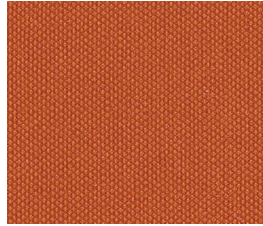

Mandarin
S20

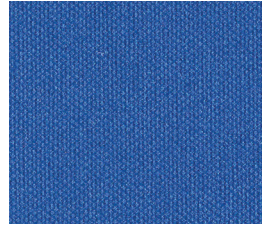

Marine
S21

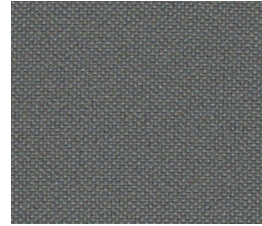

Sterling
S32

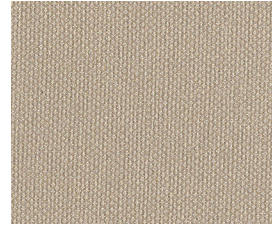

Taupe
S34

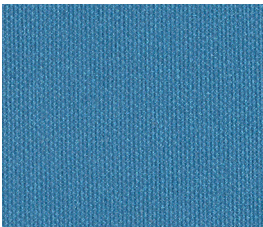

Turquoise
S35

Additional fabrics available through the Momentum 5-Click program. To view options and order samples go to www.momtex.com/mfg/315

- Grade 1 = Premium pricing (Momentum uncoated fabric)
- Grade 2 = Premium pricing (Momentum polyurethane vinyl fabric)
- Other grades and fabrics = Call for pricing and lead times

Due to pattern scale and color variations in computer monitors and printers, we strongly suggest you view actual samples before making surface material selections.



2-STEP

Application & Specification Rules

- > Always ships fully cartoned
 > Core constructed of durable foam with wood base
- > Specify cover fabric
 > Silvertex stocked colors are priced as standard; Momentum Grade 1 and 2 are priced as premium
- > Other fabrics priced as specials. Call for quote.
 > Standard with nylon glides; 3" legs and casters available separately on page 13

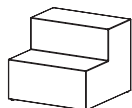

Model	Description	Max Units Per Ctn	Cubes Each Ctn	Lbs Each Ctn	List Price Standard	List Price Each Premium	Number of Legs Required
SS-ST230	38"w x 38"d x 32"h	1	30.5	76.0	\$1,663	\$1,995	4

Model Builder

Model	1st Option Fabric Color
	See page 9
SS-ST230	S08

Model Example: SS-ST230.S08

3-STEP

Application & Specification Rules

- > Always ships fully cartoned
 > Core constructed of durable foam with wood base
- > Specify cover fabric
 > Silvertex stocked colors are priced as standard; Momentum Grade 1 and 2 are priced as premium
- > Other fabrics priced as specials. Call for quote.
 > Standard with nylon glides; 3" legs and casters available separately on page 13

NEW!

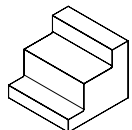

Model	Description	Max Units Per Ctn	Cubes Each Ctn	Lbs Each Ctn	List Price Standard	List Price Each Premium	Number of Legs Required
SS-ST330	38"w x 38"d x 32"h	1	30.5	76	\$1,878	\$2,180	4

Model Builder

Model	1st Option Fabric Color
	See page 9
SS-ST330	S08

Model Example: SS-ST330.S08

Square

Application & Specification Rules

- > Always ships fully cartoned
 > Core constructed of durable foam with wood base
- > Specify cover fabric
 > Silvertex stocked colors are priced as standard; Momentum Grade 1 and 2 are priced as premium
- > Other fabrics priced as specials. Call for quote.
 > Standard with nylon glides; 3" legs and casters available separately on page 13

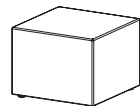

Model	Description	Max Units Per Ctn	Cubes Each Ctn	Lbs Each Ctn	List Price Each	List Price Each Premium	Number of Legs Required
SS-SQ14	18"w x 18"d x 14"h	1	4.3	16.0	\$367	\$463	4
SS-SQ18	18"w x 18"d x 18"h	1	4.3	20.0	\$428	\$540	4

Model Builder

Model	1st Option Fabric Color
	See page 9
SS-SQ18	S08

Model Example: SS-SQ18.S08



Ottoman | 38" Square

Application & Specification Rules

- > Always ships fully cartoned
- > Core constructed of durable foam with wood base
- > Specify cover fabric
- > Silvertex stocked colors are priced as standard; Momentum Grade 1 and 2 are priced as premium
- > Works with 2-Step and 3-Step as a corner unit
- > Standard with nylon glides; 3" legs and casters available separately on page 13

NEW!

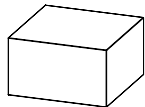

Model	Description	Max Units Per Ctn	Cubes Each Ctn	Lbs Each Ctn	List Price Each	List Price Each Premium	Number of Legs Required
SS-SQ3818	38"w x 38"d x 18"h	1			\$1,360	\$1,560	4

Model Builder

Model	1st Option Fabric Color
	See page 9
SS-SQ3818	S08

Model Example: SS-SQ3818.S08

Barrel + Barrel Slant

Application & Specification Rules

- > Always ships fully cartoned
- > Core constructed of durable foam
- > Specify cover fabric
- > Silvertex stocked colors are priced as standard; Momentum Grade 1 and 2 are priced as premium
- > Other fabrics priced as specials. Call for quote.
- > Barrel Slant features 10-degree slant on both ends.

NEW!

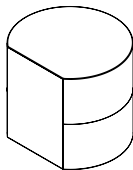

Model	Description	Max Units Per Ctn	Cubes Each Ctn	Lbs Each Ctn	List Price Standard	List Price Each Premium
SS-BA12	Barrel 16" diameter x 12" height	1	4.3	6.0	\$325	\$382
SS-BA16	Barrel 16" diameter x 16" height	1	4.3	8.0	\$357	\$422
SS-BA18	Barrel 16" diameter x 18" height	1	4.3	9.0	\$376	\$447
SS-BAS12	Barrel Slant 16" diameter x 12" height	1	4.3	6.0	\$325	\$382
SS-BAS16	Barrel Slant 16" diameter x 16" height	1	4.3	8.0	\$357	\$422
SS-BAS18	Barrel Slant 16" diameter x 18" height	1	4.3	9.0	\$376	\$447

Model Builder

Model	1st Option Fabric Color
	See page 9
SS-BA12	S08

Model Example: SS-BA12.S08

Round Rocker

Application & Specification Rules

- > Always ships fully cartoned
- > Core constructed of durable foam with polyurethane base
- > Specify cover fabric
- > Silvertex stocked colors are priced as standard; Momentum Grade 1 and 2 are priced as premium
- > Other fabrics priced as specials. Call for quote.

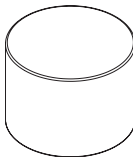

Model	Description	Max Units Per Ctn	Cubes Each Ctn	Lbs Each Ctn	List Price Standard	List Price Each Premium
SS-RR14	Round 18" diameter x 15"h	1	4.3	15.6	\$367	\$425
SS-RR18	Round 18" diameter x 19"h	1	4.3	19.6	\$421	\$489

Model Builder

Model	1st Option Fabric Color
	See page 9
SS-RR18	S08

Model Example: SS-RR18.S08



Round

Application & Specification Rules

- > Always ships fully cartoned
- > Core constructed of durable foam with wood base
- > Specify cover fabric
- > Silvertex stocked colors are priced as standard; Momentum Grade 1 and 2 are priced as premium
- > Other fabrics priced as specials. Call for quote.
- > Standard with nylon glides; 3" legs and casters available separately on page 13

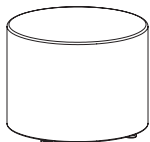

Model	Description	Max Units Per Ctn	Cubes Each Ctn	Lbs Each Ctn	List Price Standard	List Price Each Premium	Number of Legs Required
SS-RD14	Round 18" diameter x 14"h	1	4.3	13.6	\$332	\$387	4
SS-RD18	Round 18" diameter x 18"h	1	4.3	17.6	\$387	\$450	4

Model Builder

Model	1st Option Fabric Color
	See page 9
SS-RD18	S08

Model Example: SS-RD18.S08

Crescent

Application & Specification Rules

- > Always ships fully cartoned
- > Core constructed of durable foam with wood base
- > Specify cover fabric
- > Silvertex stocked colors are priced as standard; Momentum Grade 1 and 2 are priced as premium
- > Other fabrics priced as specials. Call for quote.
- > Standard with nylon glides; 3" legs and casters available separately on page 13

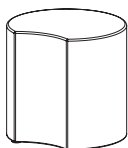

Model	Description	Max Units Per Ctn	Cubes Each Ctn	Lbs Each Ctn	List Price Standard	List Price Each Premium	Number of Legs Required
SS-CR18	18" diameter x 18"h	1	4.3	14.6	\$387	\$450	4

Model Builder

Model	1st Option Fabric Color
	See page 9
SS-CR18	S08

Model Example: SS-CR18.S08

Arcs

Application & Specification Rules

- > Always ships fully cartoned
- > Core constructed of durable foam with wood base
- > Specify cover fabric
- > Silvertex stocked colors are priced as standard; Momentum Grade 1 and 2 are priced as premium
- > Other fabrics priced as specials. Call for quote.
- > Standard with nylon glides; 3" legs and casters available separately on page 13

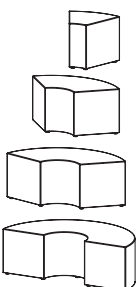

Model	Description	Max Units Per Ctn	Cubes Each Ctn	Lbs Each Ctn	List Price Standard	List Price Each Premium	Number of Legs Required
SS-R818	1/8 Circle 21"w x 19"d x 18"h	1	4.3	15.6	\$422	\$496	4
SS-R418	1/4 Circle 27"w x 21"d x 18"h	1	10.1	23.0	\$614	\$730	5
SS-R318	1/3 Circle 38"w x 23"d x 18"h	1	13.7	43.0	\$856	\$1,009	6
SS-R218	1/2 Circle 54"w x 27"d x 18"h	1	18.1	48.0	\$1,154	\$1,366	8

Model Builder

Model	1st Option Fabric Color
	See page 9
SS-R818	S08

Model Example: SS-R818.S08



Curved Bench

Application & Specification Rules

- > Always ships fully cartoned
- > Core constructed of durable foam with wood base
- > Works with Single-Face Radius Mobile Shelf ASFVSC-1742
- > Silvertex stocked colors are priced as standard; Momentum Grade 1 and 2 are priced as premium
- > Other fabrics priced as specials. Call for quote.
- > Standard with nylon glides; 3" legs and casters available separately on page 13

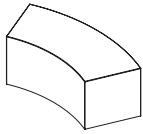

Model	Description	Max Units Per Ctn	Cubes Each Ctn	Lbs Each Ctn	List Price Standard	List Price Each Premium	Number of Legs Required
SS-BC18	18"d	1	14.7	30.0	\$979	\$1,142	8

Model Builder

Model	1st Option Fabric Color
	See page 9
SS-BC18	S08

Model Example: SS-BC18.S08

Rectangle Bench

Application & Specification Rules

- > Always ships fully cartoned
- > Core constructed of durable foam with wood base
- > Works with Single-Face Mobile Shelf ASFVS-1742
- > Silvertex stocked colors are priced as standard; Momentum Grade 1 and 2 are priced as premium
- > Other fabrics priced as specials. Call for quote.
- > Standard with nylon glides; 3" legs and casters available separately on page 13

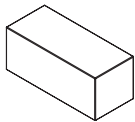

Model	Description	Max Units Per Ctn	Cubes Each Ctn	Lbs Each Ctn	List Price Standard	List Price Each Premium	Number of Legs Required
SS-RC1842	42"w x 18"d x 18"h	1	9.9	30.0	\$722	\$866	6
SS-RC1848	48"w x 18"d x 18"h	1	11.0	33.0	\$760	\$915	6

Model Builder

Model	1st Option Fabric Color
	See page 9
SS-RC1842	S08

Model Example: SS-RC1842.S08

Caster Pack

Application & Specification Rules

- > 37mm caster works with Soft Seating models with glides
- > Single pack; note number of legs required by model
- > Adds 1" to overall height
- > Standard in black

Model	Description	Units Per Ctn	Cubes Each	Lbs Each Unctn	List Price Ctn
SSA-CPS.37T1	37mm caster, adds 1" to height	1-Caster	0.1	0.4	\$12

Soft Seating Leg

Application & Specification Rules

- > 3" titanium finish leg works with Soft Seating models with glides
- > Single pack; note number of legs required by model
- > Adds 2.5" to overall height
- > Standard in titanium

Model	Description	Units Per Ctn	Cubes Each Ctn	Lbs Each Ctn	List Price Ctn
SSA-LPS3T1.5	3" leg, Titanium, adds 2.5" to height	1-Leg	0.1	0.4	\$28



Pixel

Application & Specification Rules

- > Always ships fully cartoned, two units per carton
- > Available with two base options: fixed glides (4) or rocker (R) bottom
- > Other Momentum textiles priced as specials. Call for quote.
- > Core constructed of durable foam and wood
- > Silvertex stocked colors are priced as standard; Momentum Grade 1 and 2 are priced as premium
- > Single pack cartons available; per unit \$5 NET charge



Model	Description	Dimensions	Units Per Ctn	Cubes Each Ctn	Lbs Each Ctn	List Price Standard	List Price Each Premium
ASPXL16.4	Pixel, Fixed Glide Base	16" diameter x 4" high	2	1	8.0	\$184	\$230
ASPXL16.R	Pixel, Rocker Base	16" diameter x 4" high	2	1	8.0	\$242	\$288

Model Builder

Model	1st Option Fabric Color
	See page 9
ASPXL16.4	S08

Model Example: ASPXL16.4.S08

Wire Pixel Caddy

Application & Specification Rules

- > Wire caddy on casters
- > Holds 10 ASPOT16 or 8 ASPXL16 units

Titanium finish



Model	Description	Units Per Ctn	Cubes Each Ctn	Lbs Each Ctn	List Price Each
ASPXLCAD.H.4	18" diameter x 33"h	1	6.4	15.3	\$429



Spots

Application & Specification Rules

- > Always ships fully cartoned, 3 units per carton. Must be ordered in increments of 3
- > Core constructed of durable foam
- > Single pack cartons available; per unit \$5 NET charge
- > Silvertex stocked colors are priced as standard; Momentum Grade 1 and 2 are priced as premium
- > Specify cover fabric
- > Other Momentum textiles priced as specials. Call for quote.



Model	Description	Dimensions	Units Per Ctn	Cubes Each Ctn	Lbs Each Ctn	List Price Standard	List Price Premium
ASPOT16	Padded floor seat	16" diameter; 3" height	3	0.6	1.6	\$138	\$165

Model Builder

Model	1st Option Fabric Color
	See page 9
ASPOT16	S08

Model Example: ASPOT16.S08

Rectangle Pad

Application & Specification Rules

- > Always ships fully cartoned
- > Core constructed of durable foam
- > Specify cover fabric
- > Other fabrics priced as specials. Call for quote.
- > Silvertex stocked colors are priced as standard; Momentum Grade 1 and 2 are priced as premium

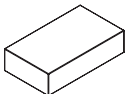

Model	Description	Seat Height	Max Units Per Ctn	Cubes Each Ctn	Lbs Each Ctn	List Price Standard	List Price Each Premium
SS-RP2414	24"w x 14"d	6"	1	2.0	3.0	\$262	\$310
SS-RP4814	48"w x 14"d	6"	1	3.9	6.0	\$367	\$460

Model Builder

Model	1st Option Fabric Color
	See page 9
SS-RP4814	S08

Model Example: SS-RP4814.S08



Application & Specification Rules

- > Always ships fully cartoned
- > Specify cover fabric
- > Other fabrics priced as specials. Call for quote.
- > Frame constructed of steel and wood with high density foam wrap
- > Silvertex stocked colors are priced as standard; Momentum Grade 1 and 2 are priced as premium



Model	Description	Dimensions	Max Units Per Ctn	Cubes Each Ctn	Lbs Each Ctn	List Price Standard	List Price Each Premium
SS-SB24	Lounge Chair	42"h x 24" w x 30"d	1	14.0	57.5	\$871	\$1,034



SS-SB48	Lounge 48" Sofa	42"h x 48" w x 30"d	1	27.4	97.5	\$1,362	\$1,629
---------	-----------------	---------------------	---	------	------	---------	---------

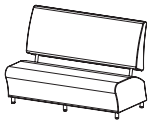

SS-SB60	Lounge 60" Sofa	42"h x 60" w x 30"d	1	33.1	115.0	\$1,744	\$2,110
---------	-----------------	---------------------	---	------	-------	---------	---------

Model Builder

Model	1st Option Fabric Color
	See page 9
SS-SB24	S08

Model Example: SS-SB24.S08

artcobell

SEATING

Seating that fits! Shape, size and posture support are effortlessly blended into a variety of ergonomic designs. Stay comfortable, alert and engaged anywhere.

STATEMENT OF LINE – 18

ADAPTABLE – 23

ALPHABET – 25

DISCOVER – 32

UNIFLEX – 38

SOLID PLASTIC – 43

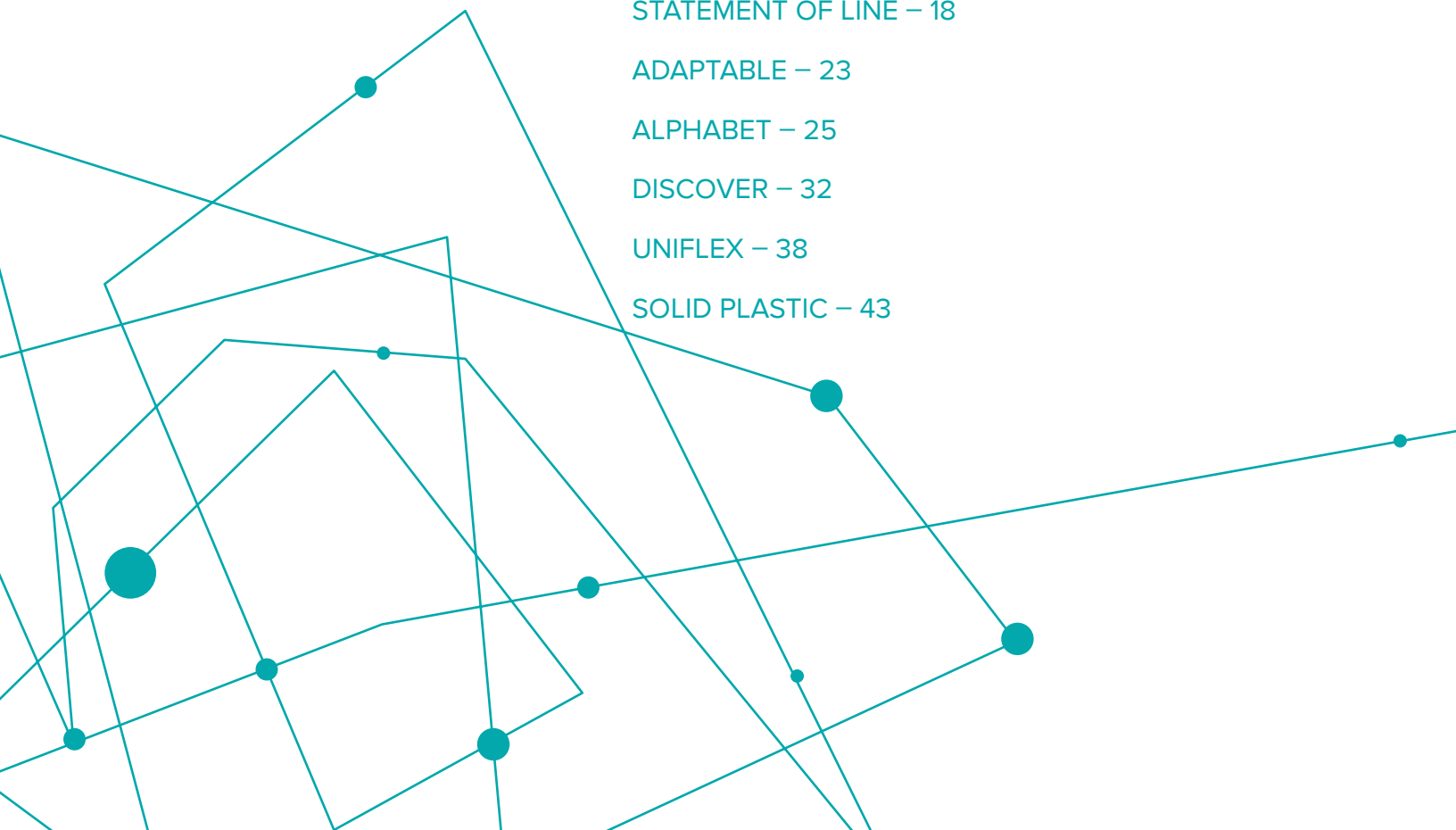

STATEMENT OF LINE

SEATING

ADAPTABLE SEATING

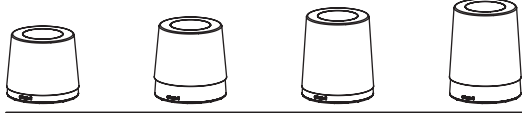

ASMOV14 ASMOV16 ASMOV18 ASMOV20

MOV Stool



ASMOV1416 ASMOV1820

MOV Stool Slipcover

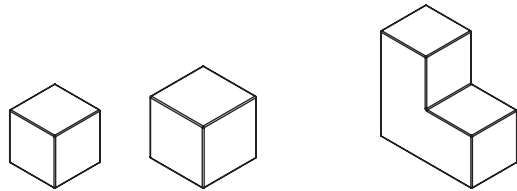

ABLOC1414 ABLOC1818

BLOC

ASTP

STP

ALPHABET SEATING



AS4L12 AS4L14 AS4L16 AS4L18

Four Leg Chair



AS4L06

FLOT Four Leg Chair

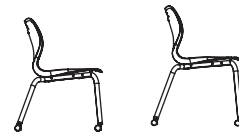

AS4C16 AS4C18

Four Leg Caster Chair



AS4R14

AS4R16

AS4R18

Rocker

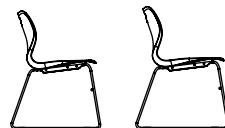

ASSL16

ASSL18

Sled Chair

STATEMENT OF LINE

SEATING

ALPHABET SEATING



ASCL12

ASCL14

ASCL16

ASCL18

AS4ST24

AS4ST30

ASTA18

ASST18

Cantilever Chair

Four Leg Stool

Task Chair

Swivel Stool

DISCOVER SEATING



D10D

D10C

D10B

D10A

D10X

D16A

D16X

D109

D15A

Four Leg Stacking Chair

Four Leg w/Book Rack

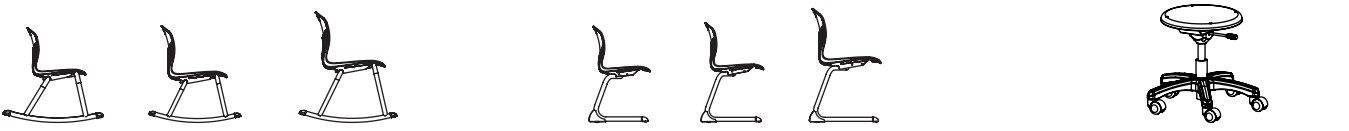

D1RC

D1RB

D1RA

D30C

D30B

D30A

DP08

Rocker

Cantilever Chair

Mobile Stool

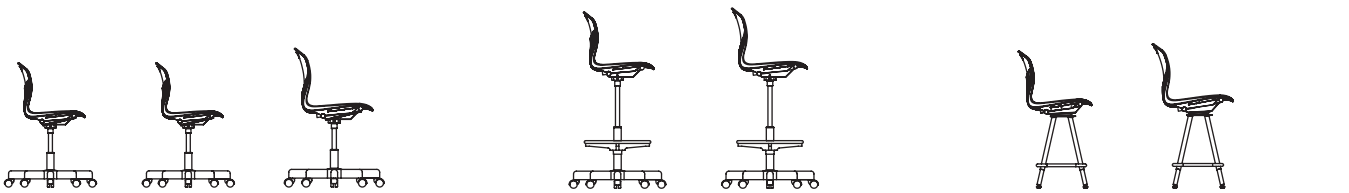

DP9B

DP9A

DP9X

DL9A

DL9X

D99A

D99X

Task Chair

Swivel Stool

Four Leg Swivel Stool

STATEMENT OF LINE

SEATING

UNIFLEX SEATING



7103 7105 7107 7108 7167 7157

Four Leg Stacking Chair



7P90

Task Chair



7L90

Swivel Stool



0801

Four Leg Stool

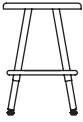

0802

SOLID PLASTIC SEATING



X105 X107

Four Leg Stacking Chair

Adaptable Seating Poly Colors



Apple Green
9E



Azure
Z



Onyx
D



Ruby Red
V



Sunset Orange
9S

Covers (MOV, DP08, 0801 ONLY) - Silvertex® Vinyl

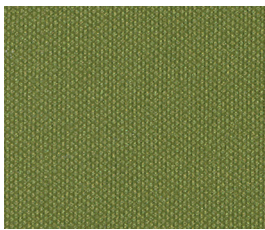

Basil
S02

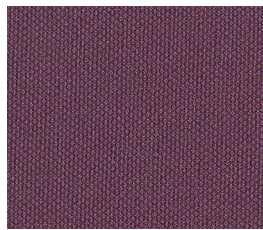

Blackberry
S04

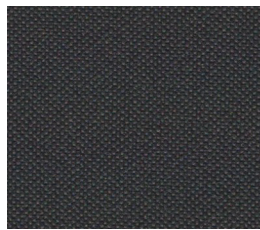

Carbon
S08

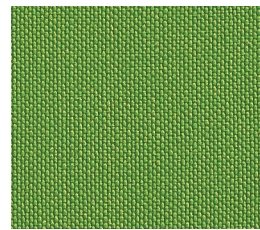

Crème De Menthe
S13

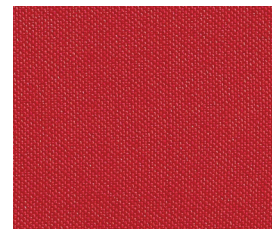

Imperial
S15

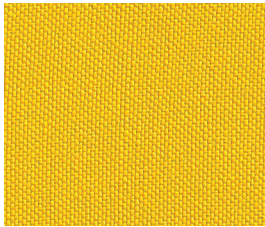

Limoncello
S18

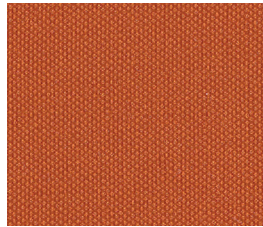

Mandarin
S20

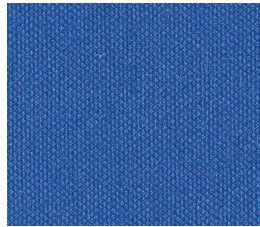

Marine
S21

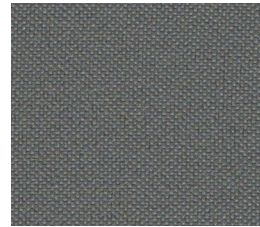

Sterling
S32

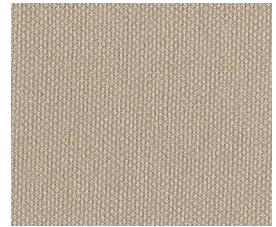

Taupe
S34

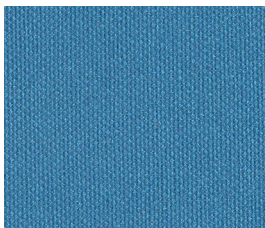

Turquoise
S35

Additional fabrics available through the Momentum 5-Click program. To view options and order samples go to www.momtex.com/mfg/315

- Grade 1 = Premium pricing (Momentum uncoated fabric)
- Grade 2 = Premium pricing (Momentum polyurethane vinyl fabric)
- Other grades and fabrics = Call for pricing and lead times

Due to pattern scale and color variations in computer monitors and printers, we strongly suggest you view actual samples before making surface material selections.

Poly Colors

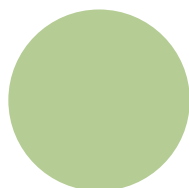

Apple Green
9E

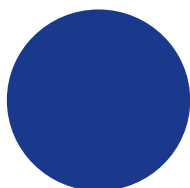

Azure
Z

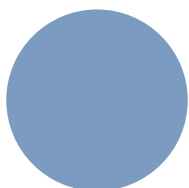

Blueberry
9H

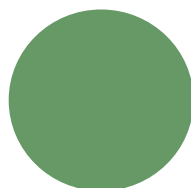

Clover
DG

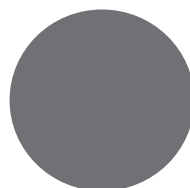

Graphite
G

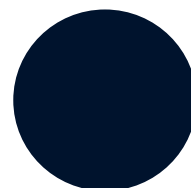

Navy Indigo
M

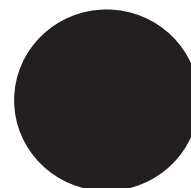

Onyx
D

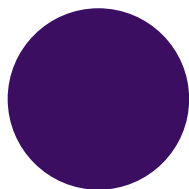

Purple Iris
93

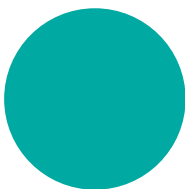

Reef
DT

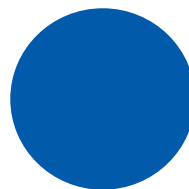

Royal Blue
9B

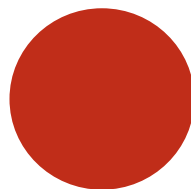

Ruby Red
V

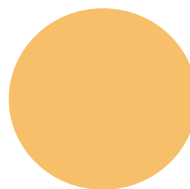

Squash
9L

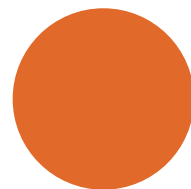

Sunset Orange
9S

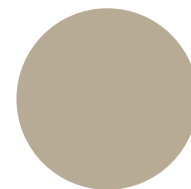

Taupe
T

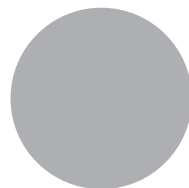

Titanium
TN

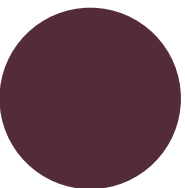

Maroon
MN

Metal Frames

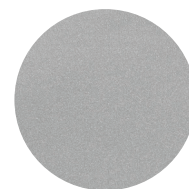

Titanium
4



Chrome
5

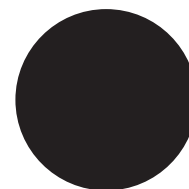

Black
7

Due to pattern scale and color variations in computer monitors and printers, we strongly suggest you view actual samples before making surface material selections.



MOV Stool

Application & Specification Rules

- > Always ships fully cartoned, one stool per carton
- > Standard convex base design allows controlled movement in all directions
- > Base provides a wider stance for stable and safe seating
- > Base and seat pad utilize a durable non-skid surface
- > Standard with dark grey base, seat pad and lower inner shell
- > Specify outer shell color



Model	Seat Height	Max Units Per Ctn	Cubes Each Ctn	Lbs Each Ctn	List Price Each
ASMOV14	14"	1	2.1	10.9	\$272
ASMOV16	16"	1	2.4	11.6	\$272
ASMOV18	18"	1	2.7	13.1	\$290
ASMOV20	20"	1	3.0	13.8	\$290

Model Builder

Model	.	1st Option Shell Color	
		Apple Green (9E)	\$0
		Azure (Z)	\$0
		Onyx (D)	\$0
		Ruby Red (V)	\$0
		Sunset Orange (9S)	\$0
ASMOV18	.	Z	

Model Example: ASMOV18.Z

MOV Stool Slipcover

Application & Specification Rules

- > Always ships fully cartoned; one slipcover per carton.
- > Order MOV stool separately.
- > Specify fabric color

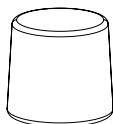

Model	Seat Height	Max Units Per Ctn	Cubes Each Ctn	Lbs Each Ctn	List Price Each	List Price Each Premium
ASMOVCVR1416	16"	1	2.7	4.0	\$176	\$204
ASMOVCVR1820	20"	1	2.7	13.1	\$186	\$214

Model Builder

Model	.	1st Option Fabric Color
		See page 21
ASMOVCVR1416	.	S02

Model Example: ASMOVCVR1416.S02

artcobell



BLOC & STP

Application & Specification Rules

> Always ships fully cartoned, one per carton

> Constructed of durable polyethylene

> Specify poly shell color

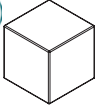

Model	Seat Height	Max Units Per Ctn	Cubes Each Ctn	Lbs Each Ctn	List Price Each
BLOC					
ABLOC1414	14"	1	2.0	8.0	\$261
ABLOC1818	18"	1	4.0	15.0	\$319



Model	Seat Height	Max Units Per Ctn	Cubes Each Ctn	Lbs Each Ctn	List Price Each
STP					
ASTP1428	14"/28"	1	7.3	22.0	\$405

Model Builder

Model	•	1st Option Shell Color	
		Apple Green (9E)	\$0
		Azure (Z)	\$0
		Onyx (D)	\$0
		Ruby Red (V)	\$0
		Sunset Orange (9S)	\$0
ABLOC1414	•	9E	

Model Example: ABLOC1414.9E



Application & Specification Rules

- > Always ships fully cartoned
- > Order in multiples of 4 (full carton quantity)
- > Chairs stack four (4) high.
FLOT chairs stack five (5) high
- > Single pack cartons available; per unit \$5 NET charge



Model	Seat Height	Units Per Ctn	Cubes Each	Lbs Each	List Price Each
Poly Shell					
AS4L12	12"	4	2.6	10.2	\$146
AS4L14	14"	4	2.6	10.7	\$146
AS4L16	16"	4	3.8	12.5	\$150
AS4L18	18"	4	3.8	13.0	\$150
FLOT					
AS4L06	6"	4	1.2	7.8	\$146

Model Builder

Model	• 1st Option Glide	• 2nd Option Frame Color	• 3rd Option Shell Color
	Nylon (3) \$0 Steel (1) \$0 Non-Skid (2) \$8 Felt (F) \$8 Boot Indigo (M) \$8 Onyx (D) \$8 Graphite (G) \$8 Ruby Red (V) \$8	Chrome (5) \$0 Titanium (4) \$0 Black (7) \$0	See page 22
AS4L16	• 3	• 4	• M

Model Example: AS4L16.3.4.M

Please note standard quantities for all seating products. There is a \$5/unit net carton fee for less-than-carton quantity orders.

artcobell



Application & Specification Rules

> Always ships fully cartoned

> Order in multiples of 4 (full carton quantity)

> Single pack cartons available; per unit \$5 NET charge



Model	Description	Seat Height	Units Per Ctn	Cubes Each	Lbs Each	List Price Each
AS4C14	Poly Shell	14"	4	2.6	10.2	\$192
AS4C16	Poly Shell	16"	4	3.8	13.7	\$196
AS4C18	Poly Shell	18"	4	3.8	14.2	\$196

Model Builder

Model	• 1st Option Caster	• 2nd Option Frame Color	• 3rd Option Shell Color
	Hard Wheel Caster (H) \$0	Chrome (5) \$0 Titanium (4) \$0 Black (7) \$0	See page 22
AS4C16	• H	• 4	• 9E

Model Example: AS4C16.H.4.9E

Please note standard quantities for all seating products. There is a \$5/unit net carton fee for less-than-carton quantity orders.



Application & Specification Rules

> Always ships fully cartoned

> Chrome frame only



Model	Description	Seat Height	Units Per Ctn	Cubes Each	Lbs Each	List Price Each
AS4R14	Poly Shell	13"	1	7.1	19.2	\$266
AS4R16	Poly Shell	15.5"	1	11.3	21.0	\$267
AS4R18	Poly Shell	17.75"	1	11.3	21.5	\$267

Model Builder

Model	• 1st Option Glide	• 2nd Option Frame Color	• 3rd Option Shell Color
	Nylon (3) \$0	Chrome (5) \$0	See page 22
AS4R18	• 3	• 5	• M

Model Example: AS4R18.3.5.M

Please note standard quantities for all seating products. There is a \$5/unit net carton fee for less-than-carton quantity orders.



Application & Specification Rules

- > Always ships fully cartoned
- > Order in multiples of 4 (full carton quantity)
- > Chairs stack four (4) high.
- > Single pack cartons available; per unit \$5 NET charge.



Model	Description	Seat Height	Units Per Ctn	Cubes Each	Lbs Each	List Price Each
ASSL16	Poly Shell	16"	4	2.7	15.0	\$259
ASSL18	Poly Shell	18"	4	2.7	15.6	\$259

Model Builder

Model	• 1st Option Glide	• 2nd Option Frame Color	• 3rd Option Shell Color
	Nylon (3) \$0 Steel (1) \$0	Chrome (5) \$0 Titanium (4) Black (7)	See page 22
ASSL18	• 3	• 5	• M

Model Example: ASSL18.3.5.M

Please note standard quantities for all seating products. There is a \$5/unit net carton fee for less-than-carton quantity orders.

artcobell



Application & Specification Rules

> Always ships fully cartoned

> Order in multiples of 4 (full carton quantity)

> Chairs stack four (4) high

> Single pack cartons available; per unit \$5 NET charge



Model	Description	Seat Height	Units Per Ctn	Cubes Each	Lbs Each	List Price Each
ASCL12	Poly Shell	12"	4	2.9	13.9	\$191
ASCL14	Poly Shell	14"	4	2.9	13.9	\$191
ASCL16	Poly Shell	16"	4	3.8	16.0	\$194
ASCL18	Poly Shell	18"	4	3.8	16.6	\$194

Model Builder

Model	• 1st Option Glide	• 2nd Option Frame Color	• 3rd Option Shell Color
	Nylon (3) \$0 Steel (1) \$0 Felt (F) \$8 Non-Skid (2) \$8	Chrome (5) \$0 Titanium (4) \$0 Black (7) \$0	See page 22
ASCL18	• 3	• 5	• M

Model Example: ASCL18.3.5.M

Please note standard quantities for all seating products. There is a \$5/unit net carton fee for less-than-carton quantity orders.

artcobell



Application & Specification Rules

> Always ships fully cartoned

> Standard with nylon solo glide

> Standard with welded foot rest



Model	Description	Seat Height	Units Per Ctn	Cubes Each	Lbs Each	List Price Each
AS4ST24	Poly Shell	24"	1	9.0	20.0	\$248
AS4ST30	Poly Shell	30"	1	11.5	22.0	\$255

Model Builder

Model	• 1st Option Glide	• 2nd Option Frame Color	• 3rd Option Shell Color
	Solo Nylon (P) \$0	Chrome (5) \$0 Titanium (4) \$0 Black (7) \$0	See page 22
AS4ST24	• P	• 5	• M

Model Example: AS4ST24.P.5.M

Please note standard quantities for all seating products. There is a \$5/unit net carton fee for less-than-carton quantity orders.

artcobell



Application & Specification Rules

- > Always ship fully cartoned, one unit per carton
- > Black base only, no color specification required

> Standard with five-star base with swivel and pneumatic height adjustment

> Lab stool includes 18" diameter metal foot ring. 10" adjustment range. 8" to 18" from floor.



Model	Description	Seat Height	Units Per Ctn	Cubes Each	Lbs Each	List Price Each
Task Chair						
ASTA18	Poly Shell	16" - 21"	1	6.2	23.5	\$279
Swivel Stool						
ASST18	Poly Shell	22" - 32"	1	6.2	28.0	\$328

Model Builder

Model	• 1st Option Glide/Caster	• 2nd Option Shell Color
	Hard Wheel Caster (H) \$0 Bell Glide (B) \$0	See page 22
ASTA18	• H	• 9E

Model Example: ASTA18.H.9E

Please note standard quantities for all seating products. There is a \$5/unit net carton fee for less-than-carton quantity orders.



Application & Specification Rules

- > Four leg and caster chairs ship without cartons on truckloads
- > Bookrack chairs must be ordered in multiples of 2 (full carton quantities)
- > Four leg chairs stack to 10 high
Caster chairs stack 4 high
- > Only D16 models have casters.
- > Bookrack chairs always ship fully cartoned



Model	Description	Seat Height	Cubes Each Unctn	Lbs Each Unctn	List Price Each
D10D	Poly	12"	1.3	5.9	\$64
D10C	Poly	14"	1.3	6.2	\$64
D10B	Poly	16"	1.4	7.6	\$82
D10A	Poly	18"	1.5	8.9	\$82
D10X	Poly	18"	1.6	12.4	\$97



With Casters					
Model	Description	Seat Height	Cubes Each Unctn	Lbs Each Unctn	List Price Each
D16A	Poly	18"	1.5	12.2	\$139
D16X	Poly	18"	1.6	13.8	\$152



Music Chair - Band Pitch					
Model	Description	Seat Height	Cubes Each Unctn	Lbs Each Unctn	List Price Each
D109	Poly	18"	1.5	8.9	\$107



With Bookrack - Always Ships Fully Cartoned						
Model	Description	Seat Height	Chairs Per Ctn	Cubes Each Ctn	Lbs Each Ctn	List Price Each
D15A	Poly	18"	2	5.9	14.4	\$156

Model Builder

Model	• 1st Option Glide/Caster	• 2nd Option Frame Color	• 3rd Option Shell Color
	Nylon (3) \$0 Steel (1) \$0 Non-Skid (2) \$8 Felt (F) \$8 Boot Indigo (M) \$8 Onyx (D) \$8 Graphite (G) \$8 Ruby Red (V) \$8	Chrome (5) \$0 Titanium (4) \$0 Black (7) \$0	See page 22
D10A	• 3	• 4	• M

Model Example: D10A.3.4.M

Please note standard quantities for all seating products. There is a \$5/unit net carton fee for less-than-carton quantity orders.

Four Leg Stacking Chair
FULLY CARTONED



Application & Specification Rules

- > **NOTE MODELS ARE FOR CARTON QUANTITIES**
- > Chairs stack to 10 high, caster chairs stack 4 high
- > By ordering a quantity of one (1) you will receive 5 chairs
- > Carton pack models for LTL Shipments
- > Carton Pack models are priced and sold as 5-packs only.
- > Caster chairs are packed 4 per carton.



Model	Description	Seat Height	Chairs Per Ctn	Cubes Ctn	Lbs Ctn	List Price Ctn
D10DC	5-Chairs, Fully Cartoned	12"	5	6.9	33.0	\$333
D10CC	5-Chairs, Fully Cartoned	14"	5	6.9	37.5	\$333
D10BC	5-Chairs, Fully Cartoned	16"	5	9.9	45.0	\$428
D10AC	5-Chairs, Fully Cartoned	18"	5	13.2	55.5	\$428
D10XC	5-Chairs, Fully Cartoned	18"	5	19.0	69.5	\$515
With Casters						
D16AC	4-Chairs, Fully Cartoned	18"	4	13.2	54.3	\$574
D16XC	4-Chairs, Fully Cartoned	18"	4	19.0	62.7	\$638
Music Chair - Band Pitch						
D109C	5-Chairs, Fully Cartoned	18"	5	13.2	54.5	\$553

Model Builder

Model	• 1st Option Glide/Caster	• 2nd Option Frame Color	• 3rd Option Shell Color
	Nylon (3) \$0 Steel (1) \$0 Non-Skid (2) \$40 (\$8 per chair) Felt (F) \$40 (\$8 per chair) Boot Indigo (M) \$40 (\$8 per chair) Onyx (D) \$40 (\$8 per chair) Graphite (G) \$40 (\$8 per chair) Ruby Red (V) \$40 (\$8 per chair)	Chrome (5) \$0 Titanium (4) \$0 Black (7) \$0	See page 22
D10AC	• 3	• 4	• M

Model Example: D10AC.3.4.M

Please note standard quantities for all seating products. There is a \$5/unit net carton fee for less-than-carton quantity orders.



Application & Specification Rules

> Always ships fully cartoned

> Chrome frame only



Model	Description	Seat Height	Units Per Ctn	Cubes Each	Lbs Each	List Price Each
D1RC	Poly	13"	1	5.5	14.2	\$152
D1RB	Poly	15.5"	1	11.3	16.3	\$169
D1RA	Poly	17.75"	1	11.3	18.4	\$169

Model Builder

Model	• 1st Option Glide	• 2nd Option Frame Color	• 3rd Option Shell Color
	Nylon (3) \$0	Chrome (5) \$0	See page 22
D1RC	• 3	• 5	• M

Model Example: D1RC.3.5.M

Please note standard quantities for all seating products. There is a \$5/unit net carton fee for less-than-carton quantity orders.

artcobell



Application & Specification Rules

> Always ships fully cartoned

> Must order in multiples of 4 (full carton quantity)

> Chairs stack 4 high



Model	Description	Seat Height	Units Per Ctn	Cubes Each	Lbs Each	List Price Each
D30C	Poly	14"	4	2.7	10.7	\$153
D30B	Poly	16"	4	3.1	12.7	\$158
D30A	Poly	18"	4	3.9	15.4	\$158

Model Builder

Model	•	1st Option Glide	•	2nd Option Frame Color	•	3rd Option Shell Color
		Nylon (3) \$0 Steel (1) \$0 Non-Skid (2) \$8 Felt (F) \$8		Chrome (5) \$0 Titanium (4) \$0 Black (7) \$0		See page 22
D30B	•	3	•	4	•	Z

Model Example: D30B.3.4.Z

Please note standard quantities for all seating products. There is a \$5/unit net carton fee for less-than-carton quantity orders.

artcobell



Application & Specification Rules

- > Always ship fully cartoned, one unit per carton
- > Black base only, no color specification required

> Standard with five-star base with swivel and pneumatic height adjustment

> Lab stool includes 18" diameter metal foot ring. 10" adjustment range. 8" to 18" from floor.



Model	Description	Seat Height	Units Per Ctn	Cubes Each	Lbs Each	List Price Each
Task Chair						
DP9B	A shell size, Poly	15" - 20"	1	6.2	22.3	\$224
DP9A	A shell size, Poly	17" - 22"	1	6.2	22.3	\$224
DP9X	A+ shell size, Poly	17" - 22"	1	6.2	23.5	\$252
Swivel Stool						
DL9A	A shell size, Poly	24" - 34"	1	6.2	29.0	\$252
DL9X	A+ shell size, Poly	24" - 34"	1	6.2	30.2	\$280

Model Builder

Model	•	1st Option Glide/Caster	•	2nd Option Shell Color
		Hard Wheel Caster (H) \$0 Bell Glide (B) \$0		See page 22
DL9A	•	H	•	9E

Model Example: DL9A.H.9E

Please note standard quantities for all seating products. There is a \$5/unit net carton fee for less-than-carton quantity orders.



Application & Specification Rules

- > Always ship fully cartoned
 > Must order in multiples of 2 (full carton quantity)
- > Includes foot rest, non-adjustable
- > Seat swivels 360-degrees



Model	Description	Seat Height	Units Per Ctn	Cubes Each	Lbs Each	List Price Each
D99A	A Shell, Poly	25" - 33"	2	5.0	22.7	\$255
D99X	A+ Shell, Poly	25" - 33"	2	5.0	23.4	\$274

Model Builder

Model	• 1st Option Glide	• 2nd Option Frame Color	• 3rd Option Shell Color
	Nylon (3) \$0 Steel (1) \$0 Non-Skid (2) \$8 Felt (F) \$8 Boot Indigo (M) \$8 Onyx (D) \$8 Graphite (G) \$8 Ruby Red (V) \$8	Chrome (5) \$0 Titanium (4) \$0 Black (7) \$0	See page 22
D99A	• 3	• 4	• DT

Model Example: D99A.3.4.DT

Please note standard quantities for all seating products. There is a \$5/unit net carton fee for less-than-carton quantity orders.



Application & Specification Rules

- > Four leg and caster chairs ship without cartons on truckloads
- > 7167 ONLY available with 50mm Hard Casters, standard black only.
- > Four leg chairs stack to 10 high
Caster chairs stack 4 high
- > Bookrack chairs must be ordered in multiples of 2 (full carton quantities)
- > Bookrack chairs always ship fully cartoned



Model	Description	Seat Height	Cubes Each Unctn	Lbs Each Unctn	List Price Each
7103	Poly	13.5"	1.0	5.4	\$61
7105	Poly	15.5"	1.1	7.3	\$78
7107	Poly	17.5"	1.2	9.2	\$78
7108	Poly	18.5"	1.3	10.1	\$92



With Casters					
7167	Poly	17.5"	1.2	11.4	\$133

With Bookrack - Always Ships Fully Cartoned



Model	Description	Seat Height	Chairs Per Ctn	Cubes Each Ctn	Lbs Each Ctn	List Price Each
7157	Poly	17.5"	2	5.9	14.4	\$153

Model Builder

Model	1st Option Glide	2nd Option Frame Color	3rd Option Shell Color
	Nylon (3) \$0 Steel (1) \$0 Non-Skid (2) \$8 Felt (F) \$8 Boot Indigo (M) \$8 Onyx (D) \$8 Graphite (G) \$8 Ruby Red (V) \$8	Chrome (5) \$0 Titanium (4) \$0 Black (7) \$0	See page 22
7103	3	4	T

Model Example: 7103.3.4.T

Please note standard quantities for all seating products. There is a \$5/unit net carton fee for less-than-carton quantity orders.



Application & Specification Rules

> NOTE MODELS ARE FOR CARTON QUANTITIES

> All chairs stack to 10 high

> Carton pack models are priced and sold as 5 packs

> Carton pack models for LTL shipments

> 7167 ONLY available with 50mm Hard Casters, standard black only.

> By ordering a quantity of one (1) you will receive 5 chairs



Model	Description	Seat Height	Chairs Per Ctn	Cubes Each Ctn	Lbs Each Ctn	List Price Ctn
7103C	5-Chairs, Fully Cartoned	13.5"	5	6.9	30.5	\$318
7105C	5-Chairs, Fully Cartoned	15.5"	5	9.9	41.0	\$408
7107C	5-Chairs, Fully Cartoned	17.5"	5	13.2	51.5	\$408
7108C	5-Chairs, Fully Cartoned	18.5"	5	13.2	60.6	\$490



With Casters						
7167C	5-Chairs, Fully Cartoned	17.5"	5	13.2	70.0	\$683

Model Builder

Model	•	1st Option Glide	•	2nd Option Frame Color	•	3rd Option Shell Color
		Nylon (3) \$0 Steel (1) \$0 Non-Skid (2) \$40 (\$8 per chair) Felt (F) \$40 (\$8 per chair) Boot Indigo (M) \$40 (\$8 per chair) Onyx (D) \$40 (\$8 per chair) Graphite (G) \$40 (\$8 per chair) Ruby Red (V) \$40 (\$8 per chair)		Chrome (5) \$0 Titanium (4) \$0 Black (7) \$0		See page 22
7107C	•	3	•	4	•	T

Model Example: 7107C.3.4.T

Please note standard quantities for all seating products. There is a \$5/unit net carton fee for less-than-carton quantity orders.



Application & Specification Rules

> Always ship fully cartoned, one unit per carton

> Lab stool includes 18" diameter metal foot ring.
10" adjustment range, 8" to 18" from floor

> Five-star base, black only



Model	Description	Seat Height	Units Per Ctn	Cubes Each	Lbs Each	List Price Each
Task Chair						
7P90	Poly	16.25" - 20.75"	1	6.2	18.0	\$213
Swivel Stool						
7L90	Poly	23" - 33"	1	6.2	24.7	\$241

Model Builder

Model	• 1st Option Glide/Caster	• 2nd Option Shell Color
	Hard Wheel Caster (H) \$0 Bell Glide (B) \$0	See page 22
7L90	• B	• 9E

Model Example: 7L90.B.9E

Please note standard quantities for all seating products. There is a \$5/unit net carton fee for less-than-carton quantity orders.



Application & Specification Rules

- > Always ship fully cartoned
- > Must order in multiples of 4 (full carton quantity)
- > 13.5" diameter seat
- > Optional seat cover available (see below)

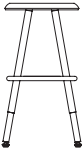

Model	Description	Seat Height	Units Per Ctn	Cubes Each	Lbs Each	List Price Each
0801	Standard Adjustable, Poly Seat	19" - 27.5"	4	2.0	13.0	\$161
0802	Standard Adjustable, Poly Seat	23.5" - 32"	4	2.0	14.0	\$178

Model Builder

Model	• 1st Option Glide	• 2nd Option Frame Color	• 3rd Option Seat Color
	Nylon (3) \$0 Steel (1) \$0 Non-Skid (2) \$8 Felt (F) \$8 Boot Indigo (M) \$8 Onyx (D) \$8 Graphite (G) \$8 Ruby Red (V) \$8	Chrome (5) \$0 Titanium (4) \$0 Black (7) \$0	See page 22
0801	• 3	• 4	• D

Model Example: 0801.3.4.D

Stool Seat Cover

Model	Description	Size	Units Per Ctn	Cubes Each	Lbs Each	List Price Standard	List Price Premium
08CVR	Stool Seat Cover	Fits 13-1/2" poly stool seat	1	1.7	2.5	\$121	\$137

Model Builder

Model	• 1st Option Fabric/EPU
	See page 21
08CVR	• S02

Model Example: 08CVR.S02

Please note standard quantities for all seating products. There is a \$5/unit net carton fee for less-than-carton quantity orders.



Application & Specification Rules

- > Always ship fully cartoned, one unit per carton
 > 13.5" seat constructed of poly
- > Standard with five-star swivel base and pneumatic height adjustment
 > Optional seat cover available (see below)
- > Black base only, no color specification required



Model	Description	Seat Height	Units Per Ctn	Cubes Each	Lbs Each	List Price Each
DP08	Mobile, swivel stool	Adjustable 16"-21"	1	2.0	14.0	\$224

Model Builder

Model	•	1st Option Glide/Caster	•	2nd Option Seat Color
		Hard Wheel Caster (H) \$0 Bell Glide (B) \$0		See page 22
DP08	.	H	.	9S

Model Example: DP08.H.9S

Stool Seat Cover

Model	Description	Size	Units Per Ctn	Cubes Each	Lbs Each	List Price Standard	List Price Premium
08CVR	Stool Seat Cover	Fits 13-1/2" poly stool seat	1	1.7	2.5	\$121	\$137

Model Builder

Model	•	1st Option Fabric/EPU
		See page 21
08CVR	.	S02

Model Example: 08CVR.S02

Please note standard quantities for all seating products. There is a \$5/unit net carton fee for less-than-carton quantity orders.



Application & Specification Rules

> Always ships fully cartoned

> All chairs stack to 4 high

> Must order in multiples of 4 (full carton quantities)



Model	Seat Height	Units Per Ctn	Cubes Each	Lbs Each	List Price Each
X105	15.5"	4	2.8	15.0	\$160
X107	17.5"	4	3.9	20.0	\$160

Model Builder

Base	• 1st Option Glide	• 2nd Option Frame Color	• 3rd Option Seat & Back Color
	Nylon (3) \$0 Steel (1) \$0 Non-Skid (2) \$8 Felt (F) \$8 Boot Indigo (M) \$8 Onyx (D) \$8 Graphite (G) \$8 Ruby Red (V) \$8	Black (7) \$0 Chrome (5) \$0 Titanium (4) \$0	Navy (N)
X105	• 3	• 7	• N

Model Example: X105.3.7.N

Please note standard quantities for all seating products. There is a \$5/unit net carton fee for less-than-carton quantity orders.

artcobell



Model	Description	Units Per Ctn	Cubes Each Ctn	Lbs Each Ctn	List Price Each
2-Wheel Universal					
016U	<ul style="list-style-type: none"> > Reference application guide below to determine compatible chair series. > Lifts under the seat 	1	11.3	31.0	\$455

CHAIR DOLLY APPLICATION GUIDE		2-Wheel Universal
Product Line	Product Series	016U
Uniflex	7100 Series Four Leg Stacking Chairs	10-Chairs
	7100 Series Four Leg Stacking Music Chairs	10-Chairs
Discover	D100 Series Four Leg Stacking Chairs	10-Chairs
	D300 Series Cantilever Chairs	4-Chairs
Alphabet	Four Leg Chairs	4-Chairs
	Cantilever Chairs	4-Chairs
Solid Plastic	X-Series Four Leg Chair	4-Chair

STUDENT DESKS

Whether you learn best in pairs, small groups, or individually, discover how any learning space can be customized. It's all about voice and choice. Reconfigure every week, day or even hour. Personalization has never been this flexible!

STATEMENT OF LINE – 35

SHAPE DESKS – 49

T-LEG SHAPE DESKS – 52

SIT-TO-STAND DESK – 53

STACKING DESK – 53

OPEN FRONT – 54

7SD SERIES – 55

FLIP TOP - 56

CANTILEVER – 56

STUDY CARREL – 57

ACCESSORIES – 58

FOUR LEG COMBO – 60

STATEMENT OF LINE

STUDENT DESKS

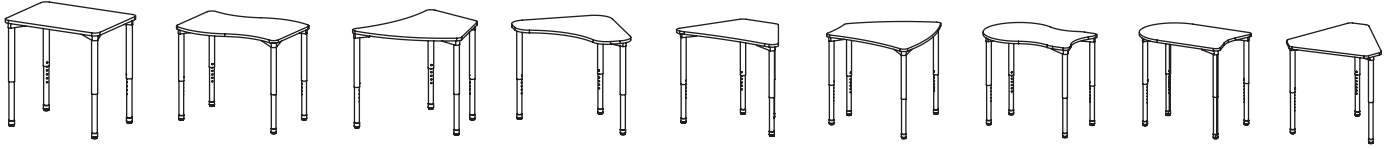

Rectangle Expanse Aperture Tri-Top Trapezoid 6 Kite Beta Linc Sail

Shape Desks

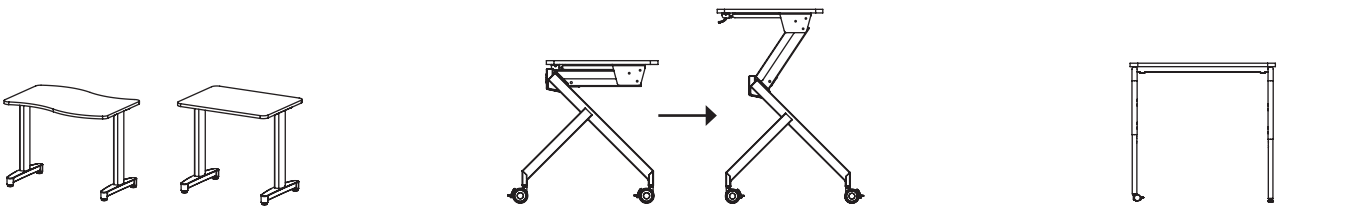

Expanse Rectangle STS-RC2228E SA2232E
T-Leg Shape Desks **Sit-to-Stand** **Stacking**



DA0D R90D D75 7457 H457S
Open Front | Poly & Metal Box **Four Leg Combo Desks**



7SD4A0 7SD4A6 7SD3A 7SD4AD 7SD4AT 20" x 26" Beta, Linc + Rectangle
7SD Series **Cantilever Desk** **Flip Top**

artcobell

Standard Laminates



Fusion Maple
7M



New Age Oak
3L



Pinnacle Walnut
F9



French Pear
H4



Crisp Linen
4E

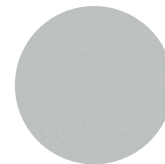

Nordic Linen
C9

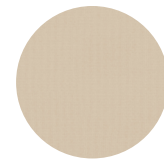

Flax Linen
5T

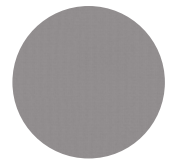

Pressed Linen
5S



Kingswood Walnut
N8



High Rise
3E

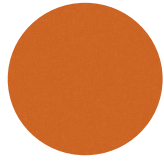

Marmalade
J1

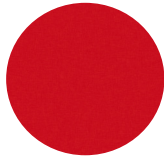

Berry
J8

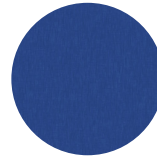

Blue Curacao
N3

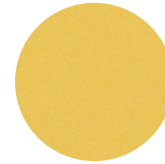

Quince
N1

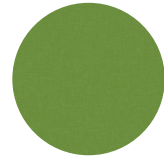

Dublin Crossweave
N5

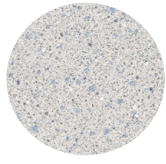

Grey Glace
18



Nepal Teak
72



Bannister Oak
08

Premium Markerboard Laminates



Folkstone
WF

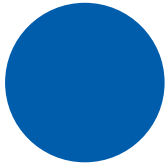

Spectrum Blue
WB



Vibrant Green
WG

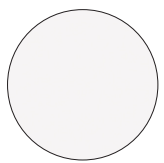

Markerboard White
W5

Edge Band

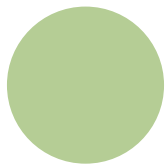

Apple Green
J

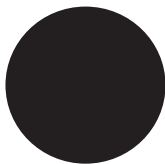

Black
0

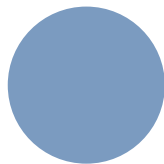

Blueberry
6

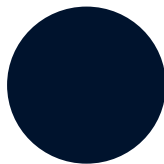

Indigo
C



Primary Red
H

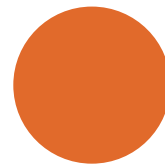

Orange
5

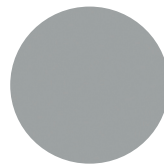

Titanium
4

Additional designs available: Most Wilsonart® Laminates are available as special orders. Minimum quantities and extended lead times will apply. Any laminate design that is **not** part of the Artcobell collection shown here will be priced as **premium**.

Due to pattern scale and color variations in computer monitors and printers, we strongly suggest you view actual samples before making surface material selections.

Poly Colors - DA0D | D75 | 7457

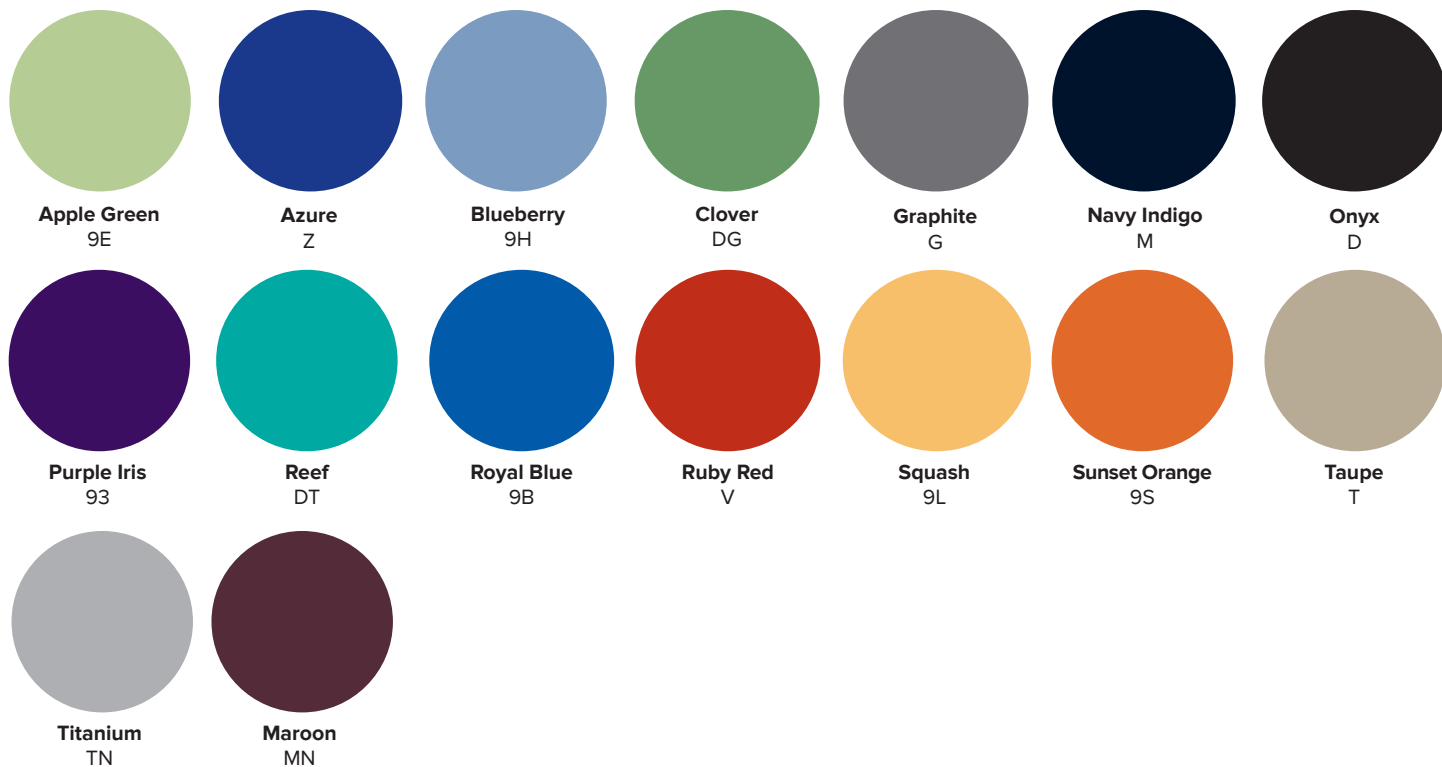

Solid Plastic *Subject to current lead times



Metal Frames

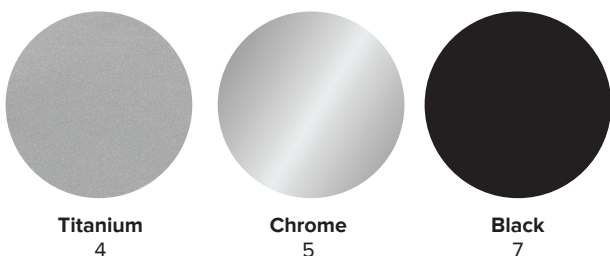

Due to pattern scale and color variations in computer monitors and printers, we strongly suggest you view actual samples before making surface material selections.









Application & Specification Rules

- > Tops and legs are specified and priced separately. See page 51 for leg kits
- > Always ships fully cartoned, one top per carton

- > Tops are NOT pre-drilled for accessories
- > DST models = 3/4" core; DHT models = 1-1/8" core.

- > Accessories are specified separately. See pages 58-59
- > DO NOT use DTLF leg sets with DST tops; use ONLY with DHT tops.

Model	Top Material Edge	Units Per Ctn	Cubes Each	Lbs Each	List Price Each Laminates	List Price Each Premium Markerboard	Number of legs required
Rectangle 20" x 26"							
 DST-RC2026E	Laminate 3/4" core Banded Flat Edge (E)	1	1.0	15.6	\$164	\$206	4
DHT-RC2026E	Laminate 1-1/8" core Banded Flat Edge (E)	1	1.0	23.4	\$192	\$234	4
Rectangle 20" x 36"							
 DST-RC2036E	Laminate 3/4" core Banded Flat Edge (E)	1	1.7	22.6	\$199	\$241	4
DHT-RC2036E	Laminate 1-1/8" core Banded Flat Edge (E)	1	1.7	33.9	\$226	\$268	4
Expanse 22" x 32"							
 DST-EX2232E	Laminate 3/4" core Banded Flat Edge (E)	1	1.1	18.4	\$199	\$241	4
DHT-EX2232E	Laminate 1-1/8" core Banded Flat Edge (E)	1	1.1	27.6	\$226	\$268	4
Aperture 18" x 30"							
 DST-AP1830E	Laminate 3/4" core Banded Flat Edge (E)	1	1.4	17.1	\$187	\$229	4
DHT-AP1830E	Laminate 1-1/8" core Banded Flat Edge (E)	1	1.4	25.7	\$215	\$257	4
Tri-Top 28" x 28"							
 DST-TT2828E	Laminate 3/4" core Banded Flat Edge (E)	1	1.3	21.4	\$192	\$234	3
DHT-TT2828E	Laminate 1-1/8" core Banded Flat Edge (E)	1	1.3	32.1	\$219	\$261	3
Trapezoid 6 20" x 32"							
 DST-T6E	Laminate 3/4" core Banded Flat Edge (E)	1	1.1	14.0	\$175	\$217	4
DHT-T6E	Laminate 1-1/8" core Banded Flat Edge (E)	1	1.1	21.0	\$202	\$244	4

Model Builder

Model	• 1st Option Top Laminate	• 2nd Option Edge Color
	See page 47	See page 47
DST-EX2232E	• 7M	• 4

Model Example: DST-EX2232E.7M.4



Application & Specification Rules

- > Tops and legs are specified and priced separately. See page 51 for leg kits
- > Always ships fully cartoned, one top per carton

- > Tops are NOT pre-drilled for accessories
- > DST models = 3/4" core; DHT models = 1-1/8" core.

- > Accessories are specified separately. See pages 58-59
- > DO NOT use DTLP leg sets with DST tops; use ONLY with DHT tops.



Model	Top Material Edge	Units Per Ctn	Cubes Each	Lbs Each	List Price Each Laminates	List Price Each Premium Markerboard	Number of legs required
Kite 30" x 32"							
DST-KT3032E	Laminate 3/4" core Banded Flat Edge (E)	1	1.5	18.0	\$233	\$275	4
DHT-KT3032E	Laminate 1-1/8" core Banded Flat Edge (E)	1	1.5	27.0	\$260	\$302	4



Beta 22" x 33"							
DST-BT2233E	Laminate 3/4" core Banded Flat Edge (E)	1	1.2	18.5	\$221	\$263	4
DHT-BT2233E	Laminate 1-1/8" core Banded Flat Edge (E)	1	1.2	27.8	\$248	\$290	4



Linc 22" x 32"							
DST-LC2232E	Laminate 3/4" core Banded Flat Edge (E)	1	1.2	18.5	\$221	\$263	4
DHT-LC2232E	Laminate 1-1/8" core Banded Flat Edge (E)	1	1.2	27.8	\$248	\$290	4



Sail 27" x 30"							
DST-SL2730E	Laminate 3/4" core Banded Flat Edge (E)	1	1.7	18.0	\$227	\$269	3
DHT-SL2730E	Laminate 1-1/8" core Banded Flat Edge (E)	1	1.7	27.0	\$255	\$297	3



Sail 30" x 34"							
DST-SL3034E	Laminate 3/4" core Banded Flat Edge (E)	1	2.2	20.0	\$233	\$275	3
DHT-SL3034E	Laminate 1-1/8" core Banded Flat Edge (E)	1	2.2	30.0	\$260	\$302	3

Model Builder

Model	• 1st Option Top Laminate	• 2nd Option Edge Color
	See page 47	See page 47
DST-EX2232E	• 7M	• 4

Model Example: DST-EX2232E.7M.4

artcobell







Application & Specification Rules

> Specify DSLP Post Legs for DST Desks (3/4" core)

> Specify DTLP Post Legs for DHT Desks (1-1/8" core)

> Specify TA-CPS37T4 for DSLP legs.
> Specify TP-CPS4 for DTLP legs.

Model	Description	Units Per Ctn	Cubes Each Ctn	Lbs Each Ctn	List Price Ctn
Seated Height Legs 1.5" Diameter (use with DST models)					
 DSLP-4AAP.3.4	22" - 34" Adjustable Legs, 4-Pack, Nylon glide, Titanium	4 pack	0.6	14.0	\$113
DSLP-4AAP.3.7	22" - 34" Adjustable Legs, 4-Pack, Nylon glide, Black	4 pack	0.6	14.0	\$113
Table Height Legs 2" Diameter (use with DHT models only)					
 DTLP-4ATP.3.4	19" - 29" Adjustable Legs, 4-Pack, Nylon glide, Titanium	4 pack	1.7	29.5	\$157
DTLP-4ATP.3.7	19" - 29" Adjustable Legs, 4-Pack, Nylon glide, Black	4 pack	1.7	29.5	\$157
Standing Height Legs 2" Diameter (use with DHT models only)					
 DTLP-4ASP.3.4	27" - 42" Adjustable Legs, 4-Pack, Nylon glide, Titanium	4 pack	1.7	29.5	\$179
DTLP-4ASP.3.7	27" - 42" Adjustable Legs, 4-Pack, Nylon glide, Black	4 pack	1.7	29.5	\$179
Casters					
 TA-CPS37T4	37mm Casters, 4-Pack, Black, for DSLP legs	4 Pack	0.1	0.9	\$32
TA-CPS4	50mm Casters, 4-Pack, Black, for DTLP legs	4 Pack	0.1	1.0	\$46

Felt Glide Pack

Application & Specification Rules

> Use with DTLP legs, field installed only

> 3/8" - 16 x 1" threaded stem

> No color specification, specify model only

> May also be used on Shape Student Desk legs (DSLPL)

> Not for use on T-Leg Student Desks

Model	Description	Units Per Ctn	Cubes Each	Lbs Each Unctn	List Price Ctn
 TA-GFK	100-Pack	100	0.1	5.0	\$388

Shape Desks | Legs



Choose the right legs for your student desks

Model	Description	RC2026E RC2036E		EX2232E		AP1830E		TT2828E		T6E		KT3032E		BT2233E		LC2233E		SL2730E SL3034E	
		DST	DHT	DST	DHT	DST	DHT	DST	DHT	DST	DHT	DST	DHT	DST	DHT	DST	DHT	DST	DHT
DSLP-4AAP	22"-34" adj. seated height legs, 1.5" dia	✓		✓		✓		✓		✓		✓		✓		✓		✓	
DTLP-4ATP	19"-29" adj. table height legs, 2" dia		✓		✓		✓		✓		✓		✓		✓		✓		✓
DTLP-4ASP	27"-42" adj. stand height legs, 2" dia		✓		✓		✓		✓		✓		✓		✓		✓		✓
DSLK-2F29G	29" fixed height t-legs, 2pk	✓		✓															
TA-CPS37T4	37mm casters, use with DSLP legs, 4pk	✓		✓		✓		✓		✓		✓		✓		✓		✓	
TA-CPS4	50mm casters, use with DTLP legs, 4pk		✓		✓		✓		✓		✓		✓		✓		✓		✓



Application & Specification Rules

- > Tops and legs are specified and priced separately. See below for leg kits
- > Tops are NOT pre-drilled for accessories
- > Accessories are specified separately. See pages 48-49
- > Always ships fully cartoned, one top per carton

Model	Top Material Edge	Units Per Ctn	Cubes Each	Lbs Each	List Price Each Laminates	List Price Each Premium Markerboard	Number of legs required
Rectangle 20" x 26"							
 DST-RC2026E	Laminate 3/4" core Banded Flat Edge (E)	1	1.0	15.6	\$164	\$206	4
DHT-RC2026E	Laminate 1-1/8" core Banded Flat Edge (E)	1	1.0	23.4	\$192	\$234	4
Rectangle 20" x 36"							
 DST-RC2036E	Laminate 3/4" core Banded Flat Edge (E)	1	1.7	22.6	\$199	\$241	4
DHT-RC2036E	Laminate 1-1/8" core Banded Flat Edge (E)	1	1.7	33.9	\$226	\$268	4
Expanse 22" x 32"							
 DST-EX2232E	Laminate 3/4" core Banded Flat Edge (E)	1	1.1	18.4	\$199	\$241	4
DHT-EX2232E	Laminate 1-1/8" core Banded Flat Edge (E)	1	1.1	27.6	\$226	\$268	4

Model Builder

Model	• 1st Option Top Laminate	• 2nd Option Edge Color
	See page 47	See page 47
DST-EX2232E	• 7M	• 4

Model Example: DST-EX2232E.7M.4

Leg Kit

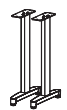

Model	Description	Units Per Ctn	Cubes Each Ctn	Lbs Each Ctn	List Price Ctn
T-Leg Kits for Shape Student Desk Tops					
DSLK-2F29G.4	29" Fixed Height, 2-Pack, Nylon glide, Titanium	2 pack	0.9	10.0	\$305
DSLK-2F29G.7	29" Fixed Height, 2-Pack, Nylon glide, Black	2 pack	0.9	10.0	\$305

artcobell



Sit-to-Stand Desk

Application & Specification Rules

- > Always ships fully cartoned, one unit per carton
- > Ships assembled. Casters are field installed.

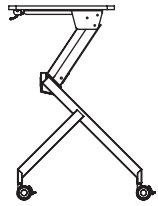
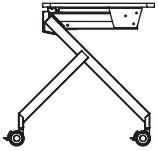

Model	Size	Top Material Edge	Height	Units Per Ctn	Cubes Each	Lbs Each	List Price Each Laminates	List Price Each Premium Markerboard
STS-RC2228E	22"x28"	Laminate 3/4" core Banded Flat Edge (E)	28"-41"	1.0	13.0	54.0	\$1,035	\$1,077

Model Builder

Model	1st Option Frame Color	2nd Option Top Color	3rd Option Edge Color
	Titanium (4) \$0	See page 47	See page 47
STS-RC2228E	4	4E	4

Model Example: STS-RC2228E.4.4E.4

Stacking Desk

Application & Specification Rules

- > Always ships fully cartoned, two units per carton
- > Must order in multiples of two (full carton quantity)
- > Ships assembled; leg inserts field installed

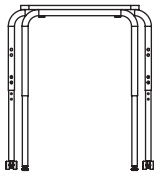

Model	Size	Top Material Edge	Height	Units Per Ctn	Cubes Each	Lbs Each	List Price Each Laminates	List Price Each Premium Markerboard
SA2232E	22"x32"	Laminate 3/4" core Banded Flat Edge (E)	22"-30"	2	4.9	29.5	\$364	\$406

Model Builder

Model	1st Option Glide	2nd Option Frame Color	3rd Option Top Color	4th Option Edge Color
	2 Nylon/2 Caster (3W)	Titanium (4) \$0	See page 47	See page 47
SA2232E	3W	4	4E	4

Model Example: SA2232E.3W.4.4E.4

artcobell

Open Front Desk | Poly Book Box

Application & Specification Rules

- > Always ships fully cartoned, two units per carton
- > Must order in multiples of 2 (full carton quantity)
- > Fully integrated polypropylene book box
- > Ships KD, field installation of legs required
- > 3/4" Core
- > When selecting a markerboard laminate, you must specify model with banded flat edge (E)



Model	Size	Top Material Edge	Height	Units Per Ctn	Cubes Each	Lbs Each	List Price Each Laminates	List Price Each Premium Markerboard
DA0D3	18" x 24"	Laminate Clear Edge (3)	22" - 30"	2	1.9	21.9	\$120	N/A
DA0DE	18" x 24"	Laminate Banded Flat Edge (E)	22" - 30"	2	1.9	21.9	\$152	\$191
DA0DS	18" x 24"	Solid Plastic (S)	22" - 30"	2	1.9	24.9	\$182	N/A
DA0E3	20" x 26"	Laminate Clear Edge (3)	22" - 30"	2	2.4	21.9	\$143	N/A
DA0EE	20" x 26"	Laminate Banded Flat Edge (E)	22" - 30"	2	2.4	21.9	\$177	\$218
DA0ES	20" x 26"	Solid Plastic (S)	22" - 30"	2	2.4	24.9	\$214	N/A

Model Builder

Model	1st Option Glide	2nd Option Frame Color	3rd Option Book Box Color	4th Option Top Color	5th Option Band Color
	Nylon (3)	Chrome (5) \$0 Black (7) \$0 Titanium (4) \$0	See page 48 \$0	See page 47	See page 47
DA0DE	3	4	M	7M	0

Model Example: DA0DE.3.4.M.7M.0

Open Front Desk | Metal Book Box

Application & Specification Rules

- > Always ships fully cartoned, two units per carton
- > Must order in multiples of 2 (full carton quantity)
- > Fully integrated metal book box, matches specified frame color
- > Desks require field installation of lower leg inserts
- > 3/4" Core
- > When selecting a markerboard laminate, you must specify model with banded flat edge (E)



Model	Size	Top Material Edge	Height	Units Per Ctn	Cubes Each	Lbs Each	List Price Each Laminates	List Price Each Premium Markerboard
R90D3	18" x 24"	Laminate Clear Edge (3)	22" - 30"	2	3.2	28.0	\$156	N/A
R90DE	18" x 24"	Laminate Banded Flat Edge (E)	22" - 30"	2	3.2	28.0	\$189	\$227
R90DS	18" x 24"	Solid Plastic (S)	22" - 30"	2	3.2	32.0	\$220	N/A
R90E3	20" x 26"	Laminate Clear Edge (3)	22" - 30"	2	3.9	29.4	\$188	N/A
R90EE	20" x 26"	Laminate Banded Flat Edge (E)	22" - 30"	2	3.9	29.4	\$223	\$264
R90ES	20" x 26"	Solid Plastic (S)	22" - 30"	2	3.9	34.2	\$259	N/A

Model Builder

Model	1st Option Glide	2nd Option Frame Color	3rd Option Top Color	4th Option Edge Color
	Nylon (3)	Black (7) \$0 Titanium (4) \$0	See page 47	See page 47
R90DE	3	4	7M	0

Model Example: R90DE.3.4.7M.0



Application & Specification Rules

- > Always ships fully cartoned, two units per carton
- > Desks require field installation of lower leg inserts
- > Must order in multiples of 2 (full carton quantity)
- > 3/4" Core
- > Accessories are specified separately. See pages 58-59
- > When selecting a markerboard laminate, you must specify model with banded flat edge (E)



Model	Top Material Edge	Height	Units Per Ctn	Cubes Each	Lbs Each	List Price Each Laminates	List Price Each Premium Markerboard
Four Leg Student Desk Rectangle 18" x 24"							
7SD4A03	Laminate Clear Edge (3)	Adjustable 22" - 30"	2	2.6	20.0	\$136	N/A
7SD4A0E	Laminate Banded Flat Edge (E)	Adjustable 22" - 30"	2	2.6	20.0	\$169	\$208
7SD4A0S	Solid Plastic (S)	Adjustable 22" - 30"	2	2.6	22.0	\$199	N/A
7SD4H03	Laminate Clear Edge (3)	Adjustable 34" - 42"	2	5.5	26.0	\$186	N/A
7SD4H0E	Laminate Banded Flat Edge (E)	Adjustable 34" - 42"	2	5.5	26.0	\$219	\$258
7SD4H0S	Solid Plastic (S)	Adjustable 34" - 42"	2	5.5	28.0	\$249	N/A



Four Leg Student Desk Rectangle 20" x 26"							
7SD4A63	Laminate Clear Edge (3)	Adjustable 22" - 30"	2	2.9	21.0	\$168	N/A
7SD4A6E	Laminate Banded Flat Edge (E)	Adjustable 22" - 30"	2	2.9	21.0	\$202	\$243
7SD4A6S	Solid Plastic (S)	Adjustable 22" - 30"	2	2.9	23.0	\$239	N/A
7SD4H63	Laminate Clear Edge (3)	Adjustable 34" - 42"	2	5.5	27.0	\$217	N/A
7SD4H6E	Laminate Banded Flat Edge (E)	Adjustable 34" - 42"	2	5.5	27.0	\$252	\$293
7SD4H6S	Solid Plastic (S)	Adjustable 34" - 42"	2	5.5	29.0	\$289	N/A



Four Leg Student Desk Rectangle 20" x 36" Wheelchair Accessible							
7SD4AD3	Laminate Clear Edge (3)	Adjustable 26" - 34"	2	5.50	29.0	\$240	N/A
7SD4ADE	Laminate Banded Flat Edge (E)	Adjustable 26" - 34"	2	5.50	29.0	\$289	\$338



Tri-Top 28" x 28"							
7SD3A3	Laminate Clear Edge (3)	Adjustable 22" - 30"	2	4.2	24.0	\$173	N/A
7SD3AE	Laminate Banded Flat Edge (E)	Adjustable 22" - 30"	2	4.2	24.0	\$211	\$255
7SD3AS	Solid Plastic (S)	Adjustable 22" - 30"	2	4.2	26.0	\$283	N/A
7SD3H3	Laminate Clear Edge (3)	Adjustable 34" - 42"	2	9.0	26.0	\$223	N/A
7SD3HE	Laminate Banded Flat Edge (E)	Adjustable 34" - 42"	2	9.0	26.0	\$260	\$304
7SD3HS	Solid Plastic (S)	Adjustable 34" - 42"	2	9.0	28.0	\$333	N/A



Trapezoid 20" x 32"							
7SD4AT3	Laminate Clear Edge (3)	Adjustable 22" - 30"	2	4.1	25.0	\$180	N/A
7SD4ATE	Laminate Banded Flat Edge (E)	Adjustable 22" - 30"	2	4.1	25.0	\$219	\$263

Model Builder

Model	1st Option Glide	2nd Option Frame Color	3rd Option Top Color	4th Option Edge Color
	Nylon (3)	Black (7) \$0 Titanium (4) \$0 Chrome (5) \$0	See page 47	See page 47
7SD4A03	3	4	7M	

Model Example: 7SD4A03.3.4.7M

4100 Series | Cantilever Desk

Application & Specification Rules

- > Always ships fully cartoned, two units per carton
- > Must order in multiples of 2 (full carton quantity)
- > Accessories are specified separately. See pages 58-59
- > 3/4" Core



Model	Size	Top Material Edge	Height	Units Per Ctn	Cubes Each	Lbs Each	List Price Each Laminates	List Price Each Premium Markerboard
4F276E	20" x 26"	Laminate Banded Flat Edge (E)	Fixed, 27"	2	6.4	31.0	\$254	\$296
4F276S	20" x 26"	Solid Plastic (S)	Fixed, 27"	2	6.4	32.0	\$325	N/A
4F296E	20" x 26"	Laminate Banded Flat Edge (E)	Fixed, 29"	2	6.4	34.0	\$254	\$296
4F296S	20" x 26"	Solid Plastic (S)	Fixed, 29"	2	6.4	35.0	\$325	N/A

Model Builder

Model	1st Option Glide	2nd Option Frame Color	3rd Option Top Color	4th Option Edge Color
	Nylon (3)	Black (7) Titanium (4)	\$0 \$0	See page 47
4F276E	3	4	7M	

Model Example: 4F276E.3.4.7M

Flip Top

Application & Specification Rules

- > Always ships fully cartoned, two units per carton
- > Must order in multiples of 2 (full carton quantity)
- > Ships fully assembled
- > 3/4" Core
- > Installed modesty panel is removable



Model	Top Material Edge	Height	Units Per Ctn	Cubes Each	Lbs Each	List Price Each Laminates	List Price Each Premium Markerboard
Beta 22" x 33"							
FTBT2233E	Laminate Banded Flat Edge (E)	29"	2	7.5	40.0	\$455	\$497
Linc 22" x 32"							
FTLC2232E	Laminate Banded Flat Edge (E)	29"	2	7.5	40.0	\$455	\$497
Rectangle 22" x 28"							
FTRC2228E	Laminate Banded Flat Edge (E)	29"	2	6.5	40.0	\$433	\$472

Model Builder

Model	1st Option Frame Color	2nd Option Top Color	3rd Option Edge Color
	Titanium (4)	See page 47	See page 47
FTRC2228E	4	7M	4

Model Example: FTRC2228E.4.7M.4



Application & Specification Rules

- > For use with the following Student Desks: DST-RC2036E
- > 1-piece opaque white acrylic study carrel screen
- > Price and specifications for screen only. Desk is priced and specified separately.
- > Dry erase marker compatible
- > Screen is 16" above work surface when installed
- > Brackets standard in Titanium finish only
- > Must order multiples of 2 (full carton quantity)

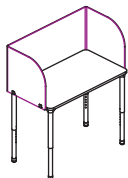

Model	Description	Units Per Ctn	Cubes Each	Lbs Each	List Price Each
TA-SCA1737.C.W	Opaque White Acrylic, 37"w x 18"d x 17"h	2	3.8	13.5	\$558



Application & Specification Rules

> NOTE CARTON QUANTITIES. All book box models are 4-packs. For example, ordering one (1) TA-BBW15 you will receive four (4) book boxes. Back pack hooks are sold individually and packed to order.

> All accessories require field installation. Student desk tops are NOT pre-drilled

> Includes mounting hardware

> No color specification is required.

Model	Description	Units Per Ctn	Cubes Each Ctn	Lbs Each Ctn	List Price Ctn
Rails/Totes (totes also work with Makerspace Cabinets)					
TA-TTR.2	Tote Tray Rails	2 PK	0.5	1.0	\$87
TA-TTR.6	Tote Tray Rails	6 PK	1.0	3.0	\$246
MSCA-TK1203.T	Tray Kit, 3”h x 12”w, Translucent, 6-Pack	6 PK	1.6	10.6	\$201
Poly Translucent Book Box, 4-Pack					
TA-BBP17	17.13”w x 13.25”d x 5.5”h	4-pack	3.1	12.0	\$212
Wire Book Box, 4-Pack					
TA-BBW15	15”w x 13.25”d x 5.25”h, Chrome	4-pack	1.9	10.0	\$153
Perforated Metal Book Box, 4-Pack					
TA-BBM16	16”w x 13.22”d x 5.13”h, Titanium	4-pack	1.6	14.0	\$287
TA-BBM22	21.75”w x 14.25”d x 5.13”h, Titanium	4-pack	3.8	17.0	\$287
Full Metal Book Box, 4-Pack					
TA-BBFM17	17”w x 14.0”d x 5”h, Titanium	4-pack	3.1	19.4	\$287
Backpack Hook, Single Pack					
TA-BPH1	2.25”w x 1.22”d x 2.35”h, Chrome	1	0.1	0.1	\$14

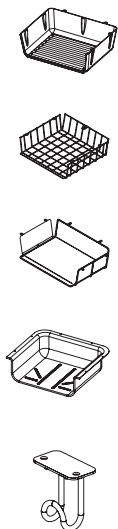

APPLICATION GUIDE						
	POLY	WIRE	PERFORATED METAL		FULL METAL	HOOK
	Universal	Small	Small	Large		
Model Number	TA-BBP17	TA-BBW15	TA-BBM16	TA-BBM22	TA-BBFM17	TA-BPH
Width	17.13”w	15”w	16”w	21.75”w	17.5” w	2.25”w
Depth	13.25”d	13.25”d	13.22”d	14.25”d	14.0” d	1.22”d
Height	5.5”h	5.25”h	5.13”h	5.13”h	5.0” h	2.35”h
18” x 24” (7SD4A0, 7SD4H0)	YES	YES	YES	NO	NO	YES
20” x 26” (7SD4A6, 7SD4H6)	YES	YES	YES	NO	YES	YES
Tri- Top (7SD3A, 7SD3H)	YES	YES	YES	NO	YES	YES
Trapezoid (7SD4AT)	YES	YES	YES	NO	YES	YES
Shape Student Desks ALL tops	YES	YES	YES	NO	YES	YES
Shape Student Desk 20” x 36” ONLY	YES	YES	YES	YES	YES	YES
4100 Series Cantilever Desk	YES	YES	YES	YES	YES	YES

artcobell

Barrier Screen

Application & Specification Rules

- > metal bracket can be attached underneath or on top of desks/tables
- > 21" x 24" clear acrylic panel creates a clean barrier between students
- > Priced and sold as four (4) packs only

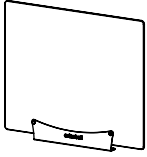

Model	Description	Units Per Ctn	Cubes Each Ctn	Lbs Each Ctn	List Price Ctn
TA-SG2124.C	21" h x 24" w acrylic panel, 4-pack	4-pack		18.2	\$480

Markerboard, Hand-Held

Application & Specification Rules

- > Markerboard is durable 1-piece opaque white acrylic
- > Priced and sold as six (6) packs only
- > Use with desk mounting brackets (specified and priced separately)

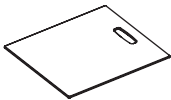

Model	Description	Units Per Ctn	Cubes Each Ctn	Lbs Each Ctn	List Price Ctn
MSCA-SK1216.W	Opaque white acrylic 12"w x 16"d	6 PK	0.4	13.0	\$428

Mounting Brackets, Desk/Table Hanging

Application & Specification Rules

- > Metal brackets are standard in Titanium finish only
- > Includes mounting hardware for field installation only
- > Priced and sold as four (4) packs only
- > Use with hand-held markerboards (specified and priced separately)
- > Easily mounts to the underside of most tables and student desks
- > Holds 1-2 markerboards per bracket



Model	Description	Units Per Ctn	Cubes Each Ctn	Lbs Each Ctn	List Price Ctn
MBH-DMB1.4	Bracket, Desk/Table Hanging, 4-Pack	4-pack	0.1	1.4	\$92

Tote Trays & Rails

Application & Specification Rules

- > Trays are 16.5"D
- > Trays are priced and specified as kits only
- > Trays are standard with integrated front handle

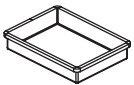

Model	Description	Units Per Ctn	Cubes Each Ctn	Lbs Each Ctn	List Price Ctn
TA-TTR.2	Tote Tray Rails	2 PK	0.5	1.0	\$87
TA-TTR.6	Tote Tray Rails	6 PK	1.0	3.0	\$246
MSCA-TK1203.T	Tray Kit, 3"h x 12"w, Translucent, 6-Pack	6 PK	1.6	10.6	\$201
MSCA-TK1206.T	Makerspace, Tray Kit, 6"h x 12"w, Translucent, 6-Pack	6 PK	2.8	14.4	\$312
MSCA-TK1212.T	Makerspace, Tray Kit, 12"h x 12"w, Translucent, 2-Pack	2 PK	2.8	14.4	\$126



D700 Series | Four Leg Combo Desk | RH Entry

Application & Specification Rules

- > Always ships fully cartoned, two units per carton
- > Standard with fixed wire book rack
- > Must order in multiples of 2 (full carton quantities)



Model	Top Size	Top Material Edge	Height	Units Per Ctn	Cubes Each	Lbs Each	List Price Each
D75A3	18" x 24"	Laminate Clear Edge (3)	18"	2	9.4	33.0	\$254
D75AS	18" x 24"	Solid Plastic (S)	18"	2	9.4	36.0	\$317
D75X3	18" x 24"	Laminate Clear Edge (3)	18"	2	10.4	34.2	\$275
D75XS	18" x 24"	Solid Plastic (S)	18"	2	10.4	38.2	\$337

Model Builder

Model	1st Option Glide	2nd Option Frame Color	3rd Option Shell Color	4th Option Top Color
	Nylon (3) \$0	Chrome (5) \$0 Black (7) \$0 Titanium (4) \$0	See page 48	See pages 47-48
D75AS	3	5	M	D

Model Example: D75AS.3.5.M.D

7400 Series | Four Leg Combo Desk | RH Entry

Application & Specification Rules

- > Always ships fully cartoned, two units per carton
- > Standard with fixed wire book rack
- > Must order in multiples of 2 (full carton quantities)



Model	Top Size	Top Material Edge	Height	Units Per Ctn	Cubes Each	Lbs Each	List Price Each
74573	18" x 24"	Laminate Clear Edge (3)	17.5"	2	9.3	33.0	\$222
7457S	18" x 24"	Solid Plastic (S)	17.5"	2	9.3	36.0	\$284

Model Builder

Model	1st Option Glide	2nd Option Frame Color	3rd Option Shell Color	4th Option Top Color
	Nylon (3) \$0	Chrome (5) \$0 Black (7) \$0 Titanium (4) \$0	See page 48	See pages 47-48
7457S	3	5	9H	D

Model Example: 7457S.3.5.9H.D

artcobell



H457 Four Leg Combo Desk | RH Entry

Application & Specification Rules

> Always ships fully cartoned, two units per carton

> Must order in multiples of 2 (full carton quantities)

> Standard with fixed wire book rack



Model	Top Size	Top Material	Height	Units Per Ctn	Cubes Each	Lbs Each	List Price Each
H457S	18" x 24"	Solid Plastic (S)	17.5"	2	9.3	41.0	\$344

Model Builder

Model	1st Option Glide	2nd Option Frame Color	3rd Option Shell Color	4th Option Top Color
	Nylon (3) \$0	Chrome (5) \$0 Black (7) \$0 Titanium (4) \$0	Navy (N)	Grey Spectrum (J) Sugar Maple (D) Walnut (W)
H457S	• 3	• 5	• N	• D

Model Example: H457S.3.5.N.D

artcobell

TABLES

The art of individuals coming together for a common goal, that's collaboration. Sit, stand, nest or rest, tables have never been so flexible. Pull up a seat, share an idea and let's get to work!

STATEMENT OF LINE – 63

SHAPE – 66

T-LEG – 70

MULTIPURPOSE (CATALYST) – 71

MAKERSPACE FRAME – 72

MAKERSPACE TOP – 73

MAKERSPACE COMPONENTS – 74

COMPUTER – 75

CAFÉ – 76

ACTIVITY – 78

CONVERTIBLE BENCH – 80

STATEMENT OF LINE

TABLES

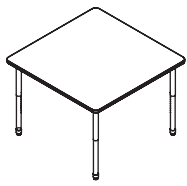

Square

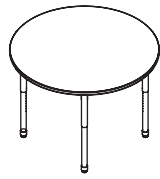

Round

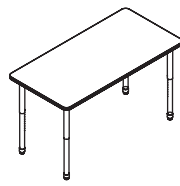

Rectangle



Aperture



3P-120

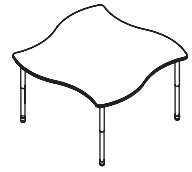

Nova

Shape Tables



Expanse

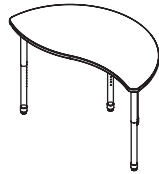

Nebula

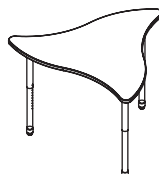

Gravity

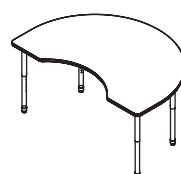

Kidney



Half-Round

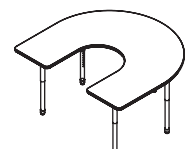

Horseshoe

Shape Tables



Star

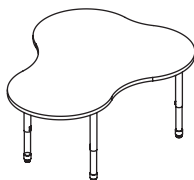

4P

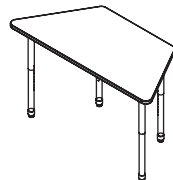

Trapezoid

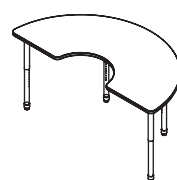

Half Moon

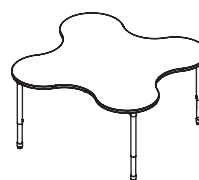

Puddle

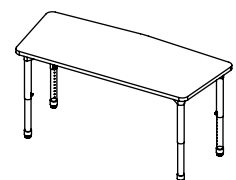

Chevron

Shape Tables



Crescent



Multi-Media



Rectangle



Expanse

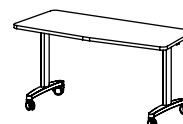

Chevron



Half-Round

Shape Tables

T-Leg Tables | Nesting

T-Leg Table | Fixed

STATEMENT OF LINE

TABLES



DTMA (25" - 34")
Multipurpose Table

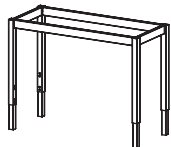

DTMF (25" - 42")
Frame

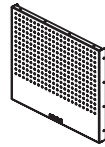

MSTA-EP
End Panel Kit



MSTA-SL
Lower Shelf Kit



DTMT
Table Tops

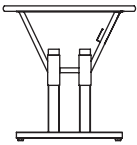

24"d (CY13-CY16)
CY Series

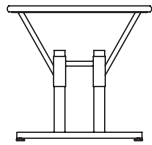

30"d (CY03-CY06)

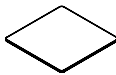

Square



Round



Racetrack

Café Tables | Tops



DCBR 30"

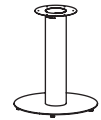

DCBR 42"

Cafe Tables | Bases



Rectangle



Round



Square



Half Round



Trapezoid



Horseshoe



Kidney

Activity Tables



Clover



Flower

Activity Tables

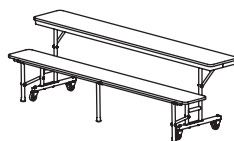

ABC | Convertible
Convertible Bench Table

Standard Laminates



Premium Markerboard Laminates

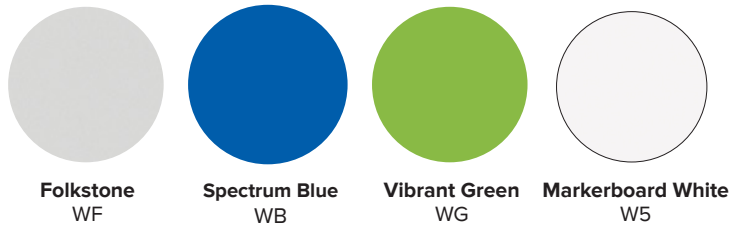

Edge Band

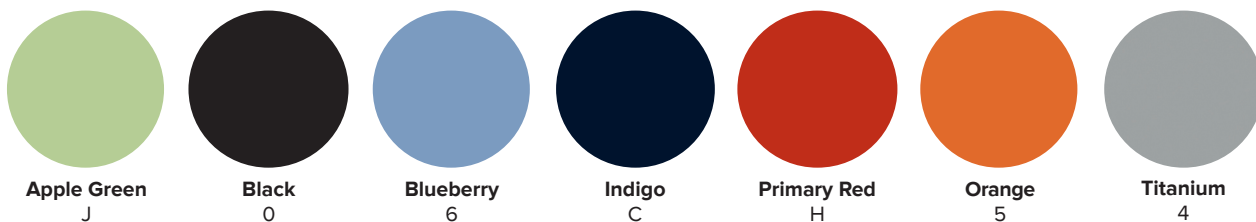







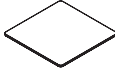

Additional designs available: Most Wilsonart® Laminates are available as special orders. Minimum quantities and extended lead times will apply. Any laminate design that is **not** part of the Artcobell collection shown here will be priced as **premium**.

Due to pattern scale and color variations in computer monitors and printers, we strongly suggest you view actual samples before making surface material selections.

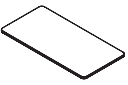

Application & Specification Rules

- > Tops and legs are specified and priced separately. Use DTLP (page 68) leg kits
- > Tops and legs ship in separate cartons
- > Always ships fully cartoned, one top per carton
- > 3" round grommets available for field installation. Specify separately. See page 87
- > 1 1/8" core standard

Model	Top Material Edge	Size	Units Per Ctn	Cubes Each Ctn	Lbs Each Ctn	List Price Each Laminates	List Price Each Premium Markerboard	Number of Legs Required
Square								
 DTT-SQ36E	Laminate 1-1/8" core Banded Flat Edge (E)	36" X 36"	1	4.1	58.0	\$224	\$358	4
DTT-SQ42E	Laminate 1-1/8" core Banded Flat Edge (E)	42" X 42"	1	5.5	71.7	\$337	\$472	4
DTT-SQ48E	Laminate 1-1/8" core Banded Flat Edge (E)	48" X 48"	1	7.0	101.3	\$346	\$484	4
Round								
 DTT-RD36E	Laminate 1-1/8" core Banded Flat Edge (E)	36"	1	4.1	37.9	\$224	\$358	4
DTT-RD42E	Laminate 1-1/8" core Banded Flat Edge (E)	42"	1	5.2	58.2	\$337	\$472	4
DTT-RD48E	Laminate 1-1/8" core Banded Flat Edge (E)	48"	1	6.7	75.0	\$346	\$484	4
DTT-RD60E	Laminate 1-1/8" core Banded Flat Edge (E)	60"	1	10.4	98.1	\$561	\$865	4
Rectangle								
 DTT-RC2436E	Laminate 1-1/8" core Banded Flat Edge (E)	24"x36"	1	2.3	30	\$234	\$336	4
DTT-RC2448E	Laminate 1-1/8" core Banded Flat Edge (E)	24" x 48"	1	3.7	44.4	\$263	\$366	4
DTT-RC2460E	Laminate 1-1/8" core Banded Flat Edge (E)	24" x 60"	1	4.5	58.9	\$318	\$444	4
DTT-RC2472E	Laminate 1-1/8" core Banded Flat Edge (E)	24" x 72"	1	5.3	69.7	\$355	\$498	4
DTT-RC3048E	Laminate 1-1/8" core Banded Flat Edge (E)	30" x 48"	1	4.5	54.3	\$285	\$400	4
DTT-RC3060E	Laminate 1-1/8" core Banded Flat Edge (E)	30" x 60"	1	5.5	72.6	\$338	\$473	4
DTT-RC3072E	Laminate 1-1/8" core Banded Flat Edge (E)	30" x 72"	1	6.5	90.6	\$377	\$527	4
DTT-RC3660E	Laminate 1-1/8" core Banded Flat Edge (E)	36" x 60"	1	6.5	88.8	\$402	\$563	4
DTT-RC3672E	Laminate 1-1/8" core Banded Flat Edge (E)	36" x 72"	1	7.7	108.2	\$425	\$592	4
Aperture								
 DTT-AP2440E	Laminate 1-1/8" core Banded Flat Edge (E)	24"x 40"	1	4.4	44.4	\$427	\$598	4
3P-120								
 DTT-3P3060E	Laminate 1-1/8" core Banded Flat Edge (E)	30" x 60"	1	9.5	86.1	\$617	\$865	6
Nova								
 DTT-NV60E	Laminate 1-1/8" core Banded Flat Edge (E)	60"	1	10.4	145.0	\$617	\$865	4
Expanse								
 DTT-EX3054E	Laminate 1-1/8" core Banded Flat Edge (E)	30" x 54"	1	6.1	69.0	\$402	\$563	4
Nebula								
 DTT-NB3054E	Laminate 1-1/8" core Banded Flat Edge (E)	30" x 54"	1	5.1	35.0	\$389	\$543	4

Model Builder

Model	• 1st Option Top Laminate	• 2nd Option Edge Color
	See page 65	See page 65
DTT-AP2440E	• 7M	• 4

Model Example: DTT-AP2440E.7M.4

artcobell



Application & Specification Rules

- > Tops and legs are specified and priced separately. Use DTLP (page 68) leg kits
- > Tops and legs ship in separate cartons
- > Always ships fully cartoned, one top per carton
- > 3" round grommets available for field installation. Specify separately. See page 87
- > 1 1/8" core standard

Model	Top Material Edge	Size	Units Per Ctn	Cubes Each Ctn	Lbs Each Ctn	List Price Each Laminates	List Price Each Premium Markerboard	Number of Legs Required
Gravity								
DTT-GV50E	Laminate 1-1/8" core Banded Flat Edge (E)	50"	1	7.1	45.0	\$510	\$714	3
Star								
DTT-ST60E	Laminate 1-1/8" core Banded Flat Edge (E)	60"	1	10.1	88.2	\$617	\$865	5
Kidney								
DTT-KD4872E	Laminate 1-1/8" core Banded Flat Edge (E)	48" x 72"	1	10.1	112.4	\$532	\$745	4
Half Round								
DTT-HR48E	Laminate 1-1/8" core Banded Flat Edge (E)	48"	1	3.7	51.0	\$304	\$429	4
Horseshoe								
DTT-HS6066E	Laminate 1-1/8" core Banded Flat Edge (E)	60" x 66"	1	11.4	116.2	\$617	\$865	4
4P								
DTT-4P4860E	Laminate 1-1/8" core Banded Flat Edge (E)	48" x 60"	1	9.5	86.1	\$545	\$765	4
Trapezoid								
DTT-TZ3060E	Laminate 1-1/8" core Banded Flat Edge (E)	30" x 60"	1	5.1	63.5	\$346	\$483	4
Half Moon								
DTT-HM3672E	Laminate 1-1/8" core Banded Flat Edge (E)	36" x 72"	1	7.7	79.8	\$425	\$592	4
Puddle								
DTT-PD60E	Laminate 1-1/8" core Banded Flat Edge (E)	60"	1	10.4	88.2	\$617	\$865	4
Crescent								
DTT-CR3042E	Laminate 1-1/8" core Banded Flat Edge (E)	30" x 42"	1	5.2	58.2	\$378	\$532	4
Multi-Media								
DTT-MM4872E	Laminate 1-1/8" core Banded Flat Edge (E)	48" x 72"	1	10.1	112.4	\$532	\$745	4
Chevron								
DTT-CV2460E	Laminate 1-1/8" core Banded Flat Edge (E)	24" x 60"	1	5.5	72.6	\$402	\$563	4

Model Builder

Model	• 1st Option Top Laminate	• 2nd Option Edge Color
	See page 65	See page 65
DTT-AP2440E	• 7M	• 4

Model Example: DTT-AP2440E.7M.4



Shape Table Leg Kit

Application & Specification Rules

- > Legs and tops are specified and priced separately. Use with DTT tops only, see pages 66-67
- > Legs are field installed
- > Casters and felt glides are available for field installation.
- > Tops and legs ship in separate cartons
- > Standard with nylon glides, 3/4" leveling range
- > Does not require quick-set brackets



Model	Description	Height	Units Per Ctn	Cubes Each Ctn	Lbs Each Ctn	List Price Ctn
Juvenile Height Legs 2" Diameter						
DTLP-4AJP	4-Legs	13" - 18"	4-Legs	1.3	26.0	\$146



Table Height Legs 2" Diameter						
DTLP-4ATP	4-Legs	19" - 29"	4-Legs	1.3	21.0	\$157



Standing Height Legs 2" Diameter						
DTLP-4ASP	4-Legs	27" - 42"	4-Legs	1.7	29.5	\$179

Model Builder

Model	• 1st Option Glide	• 2nd Option Leg Color
	Nylon (3)	Titanium (4) \$0 Black (7) \$0
DTLP-4ATP	• 3	• 4

Model Example: DTLP-4ATP.3.4

Caster Pack

Application & Specification Rules

- > For use on Shape Table Legs (DTLP)
- > All casters are standard locking 360 degree swivel
- > Casters are NOT approved for use on Nebula tops
- > 50mm Dual-Soft wheel casters, 3/8"-16 x 1" threaded stem, black only
- > Field installed only
- > Casters add 2" to the height range

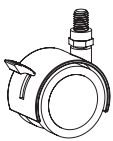

Model	Description	Units Per Ctn	Cubes Each	Lbs Each Unctn	List Price Ctn
TA-CPS4	4-Pack	4-pack	0.02	1.0	\$46

Felt Glide Pack

Application & Specification Rules

- > Use with DTLP legs, field installed only
- > 3/8" - 16 x 1" threaded stem
- > No color specification, specify model only
- > May also be used on Shape Student Desk legs (DSLPL)
- > Not for use on T-Leg Student Desks



Model	Description	Units Per Ctn	Cubes Each	Lbs Each Unctn	List Price Ctn
TA-GFK	100-Pack	100	0.1	5.0	\$388



Barrier Screen

Application & Specification Rules

- > metal bracket can be attached underneath or on top of desks/tables
- > 21" x 24" clear acrylic panel creates a clean barrier between students
- > Priced and sold as four (4) packs only

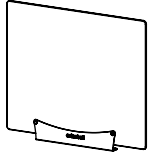

Model	Description	Units Per Ctn	Cubes Each Ctn	Lbs Each Ctn	List Price Ctn
TA-SG2124.C	21" h x 24" w acrylic panel, 4-pack	4-pack		18.2	\$480

Shape Table Screens

Application & Specification Rules

- > Use on rectangular tops for privacy above or below work surface
- > Field installed, tops are not pre-drilled
- > 12" screens may be installed in two positions. Above as a privacy screen (9" above worksurface) or below as a modesty panel (12" below worksurface)
- > Clear, frosted acrylic panels
- > Includes screen, brackets and hardware

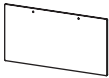

Model	Size	Units Per Ctn	Cubes Each Ctn	Lbs Each Ctn	List Price Each
TA-SA1224.F	12"h x 24"w	1	0.3	4.0	\$175
TA-SA1236.F	12"h x 36"w	1	0.5	5.8	\$261

Application Guide | Shape Table Tops

Table	Table Width			Table Depth		
	36"w	48"w	60"w	24"d	30"d	36"d
Use Screen Width	24"w	36"w	36"w	n/a	24"w	24"w

* 24"w screens may be used on the following shapes/sizes: 3P3060 (3), AP2440 (2), EX3054 (2)



Application & Specification Rules

- > 1 1/8" core standard
 > Ordered and sold as a COMPLETE table (top & legs)
 > Field installation of legs required
- > Standard with casters includes 2-locking and 2 non-locking dual wheel black casters
 > Two handle operation required to unlatch and pivot top
- > Depth of unit (except foot) when flipped up/storage position is 8-1/4"
 > Grommets available as a separately specified and field installed item. See page 87

Model	Description	Size	Leg Type Height	Units Per Ctn	Cubes Each Ctn	Lbs Each Ctn	List Price Each Laminates	List Price Each Premium Markerboard
-------	-------------	------	-------------------	---------------	----------------	--------------	---------------------------	-------------------------------------

Rectangle

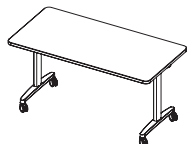

DTN-RC24F	Laminate Flat Edge (F)	24"d x 54"w	Nesting, 29" Fixed	1	6.4	71.9	\$856	\$959
DTN-RC25F	Laminate Flat Edge (F)	24"d x 60"w	Nesting, 29" Fixed	1	6.9	78.9	\$912	\$1,037
DTN-RC26F	Laminate Flat Edge (F)	24"d x 72"w	Nesting, 29" Fixed	1	8.0	89.7	\$949	\$1,091
DTN-RC34F	Laminate Flat Edge (F)	30"d x 54"w	Nesting, 29" Fixed	1	6.4	84.7	\$879	\$994
DTN-RC35F	Laminate Flat Edge (F)	30"d x 60"w	Nesting, 29" Fixed	1	6.9	92.6	\$932	\$1,066
DTN-RC36F	Laminate Flat Edge (F)	30"d x 72"w	Nesting, 29" Fixed	1	8.0	110.6	\$971	\$1,121

Expanse

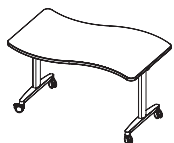

DTN-EX34F	Laminate Flat Edge (F)	30"d x 54"w	Nesting, 29" Fixed	1	6.4	89.0	\$996	\$1,157
-----------	--------------------------	-------------	--------------------	---	-----	------	-------	---------

Chevron

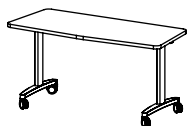

DTN-CV25F	Laminate Flat Edge (F)	24"d x 60"w	Nesting, 29" Fixed	1	6.9	85.0	\$996	\$1,157
-----------	--------------------------	-------------	--------------------	---	-----	------	-------	---------

Model Builder

Model	1st Option Frame Color	2nd Option Top Laminate	3rd Option Edge Color
	Titanium (4) Black (7)	See page 65	See page 65
DTN-RC25F	4	7M	4

Model Example: DTN-RC25F.4.7M.4

Half-Round (Fixed Leg | Non-Nesting)



DTF-HR48F	Laminate Flat Edge (F)	32"d x 48"w	29" Fixed	1	6.2	69.0	\$776	\$901
DTF-HR60F	Laminate Flat Edge (F)	30"d x 60"w	29" Fixed	1	6.9	73.0	\$805	\$941

Model Builder

Model	1st Option Glide	2nd Option Frame Color	3rd Option Top Laminate	4th Option Edge Color
	Caster (H) \$0	Titanium (4) Black (7) \$0	See page 65	See page 65
DTF-HR48F	H	4	7M	4

Model Example: DTF-HR48F.H.4.7M.4



Application & Specification Rules

- > Complete table, ships KD in single carton
- > Standard with nylon glide. Optional steel glide available
- > 1 1/8" core standard
- > 1.5" x 1.5" 14ga steel leg attaches to apron/frame with bolts
- > Tops ship attached to frame, legs ship unassembled, field assembly required
- > Optional caster packs available for field installation. See page 69
- > 1" x 2" 14ga steel fully welded apron/frame construction
- > Specify upper leg/frame paint color, lower leg insert is chrome only



Model	Description	Size	Leg Type Height	Units Per Ctn	Cubes Each Ctn	Lbs Each Ctn	List Price Each Laminates	List Price Each Premium Markerboard
DTMA2448F	Laminate Flat Edge (F)	24"d x 48"w	Adjustable 25" - 34"	1	2.6	61.6	\$574	\$675
DTMA2454F	Laminate Flat Edge (F)	24"d x 54"w	Adjustable 25" - 34"	1	3.2	75.0	\$606	\$710
DTMA2460F	Laminate Flat Edge (F)	24"d x 60"w	Adjustable 25" - 34"	1	3.2	87.9	\$608	\$735
DTMA2472F	Laminate Flat Edge (F)	24"d x 72"w	Adjustable 25" - 34"	1	3.7	91.9	\$653	\$796
DTMA3060F	Laminate Flat Edge (F)	30"d x 60"w	Adjustable 25" - 34"	1	3.9	95.8	\$630	\$766
DTMA3072F	Laminate Flat Edge (F)	30"d x 72"w	Adjustable 25" - 34"	1	4.6	114.8	\$674	\$825
DTMA3672F	Laminate Flat Edge (F)	36"d x 72"w	Adjustable 25" - 34"	1	5.5	129.6	\$727	\$896

Model Builder

Model	1st Option Glide	2nd Option Frame Color	3rd Option Top Laminate	4th Option Edge Color
	Nylon (3) \$0 Steel (1) \$0	Black (7) \$0 Titanium (4) \$0	See page 65	See page 65
DTMA2454F	1	4	3L	0

Model Example: DTMA2454F.1.4.3L.0

Application & Specification Rules

- > Frame ONLY
- > 2.0" x 2.0" 14-gauge legs with 1" x 3" 14-gauge fully welded unitized legs and frame. 30"d and 36"d frames include two (2) 13 gauge L-channel cross-supports.
- > Frames and tops are priced and specified separately
- > Frames and tops ship in separate cartons, field assembly of tops required
- > Standard with nylon glide. Optional steel glide available.
- > Specify frame paint color. Insert is painted to match frame
- > Optional caster packs available for field installation. See page 74
- > Includes attachment hardware for laminate tops

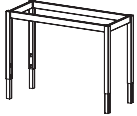

Model	Size	Description	Max Units Per Ctn	Cubes Each Ctn	Lbs Each Ctn	List Price Each
DTMF-RC2448S	24" x 48"	25" - 42" Tall Adjustable Leg (S)	2	12.3	54.8	\$528
DTMF-RC2454S	24" x 54"	25" - 42" Tall Adjustable Leg (S)	2	13.9	56.7	\$535
DTMF-RC2460S	24" x 60"	25" - 42" Tall Adjustable Leg (S)	2	15.4	58.6	\$530
DTMF-RC2472S	24" x 72"	25" - 42" Tall Adjustable Leg (S)	2	18.4	52.5	\$546
DTMF-RC3060S	30" x 60"	25" - 42" Tall Adjustable Leg (S)	2	18.9	60.5	\$540
DTMF-RC3072S	30" x 72"	25" - 42" Tall Adjustable Leg (S)	2	22.6	64.4	\$549
DTMF-RC3672S	36" x 72"	25" - 42" Tall Adjustable Leg (S)	2	26.9	66.3	\$557

Model Builder

Model	•	1st Option Glide	•	2nd Option Frame Color
		Nylon (3) \$0 Steel (1) \$0		Black (7) \$0 Titanium (4) \$0
DTMF-RC2448S	•	3	•	4

Model Example: DTMF-RC2448S.3.4

Application & Specification Rules

- > Top ONLY
- > Epoxy tops are 1" thick.
Laminate tops are 1-1/8" thick.
- > Tops and frames ship in separate cartons, field assembly of tops required
- > Use with Makerspace table frames only
- > Epoxy tops ship on pallets, black color only
- > Tops and frames are priced and specified separately
- > Adhesive is recommended for attachment of epoxy tops. Adhesive must be sourced locally

Model	Size	Units Per Ctn	Cubes Each Ctn	Lbs Each Ctn	List Price Each Laminates	List Price Each Premium Markerboard
1 1/8" Laminate Flat Edge (F)						
DTMT-RC2448F	24" x 48"	1	3.7	44.4	\$263	\$362
DTMT-RC2454F	24" x 54"	1	4.5	51.7	\$302	\$422
DTMT-RC2460F	24" x 60"	1	4.5	58.9	\$318	\$444
DTMT-RC2472F	24" x 72"	1	5.3	69.7	\$355	\$498
DTMT-RC3060F	30" x 60"	1	5.5	72.6	\$338	\$473
DTMT-RC3072F	30" x 72"	1	6.5	90.6	\$377	\$527
DTMT-RC3672F	36" x 72"	1	7.7	108.2	\$425	\$592



Epoxy (Y)						
DTMT-RC2448Y	24" x 48"	1	1	96	\$660	n/a
DTMT-RC2454Y	24" x 54"	1	1.1	108	\$750	n/a
DTMT-RC2460Y	24" x 60"	1	1.2	120	\$840	n/a
DTMT-RC2472Y	24" x 72"	1	1.3	144	\$991	n/a
DTMT-RC3060Y	30" x 60"	1	1.4	150	\$1,030	n/a
DTMT-RC3072Y	30" x 72"	1	1.6	180	\$1,235	n/a
DTMT-RC3672Y	36" x 72"	1	1.9	216	\$1,481	n/a



Model Builder

Model	•	1st Option Top Color	•	2nd Option Edge Color
		LAMINATES See page 65		See page 65
		EPOXY Black Black Edge (Q)		* Do not specify edge color on epoxy top
DTMT-RC2448Y	•	Q	•	

Model Example: DTMT-RC2448Y.Q

Caster Pack

Application & Specification Rules

- > Use with all medium or heavy duty table legs
- > Recommended weight capacity per caster = 125 lbs. (e.g., 2 casters = 250 lb. capacity)
- > Adjustable height table may be used with two (2) or four (4) casters
- > Adjustable height range with casters varies with caster selection

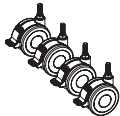

Model	Description	Units Per Ctn	Cubes Ctn	Lbs Ctn	List Price Ctn
TA-CPTD3	Locking 4-Pack 75mm	4	0.1	2	\$74

Table End Panel Kit

Application & Specification Rules

- > Use with Makerspace table frame only
- > Makerspace table frame is priced and specified separately
- > Kit includes two (2) end panels and mounting hardware
- > Standard metal peg-board design, 1/4" holes on 1" centers
- > Field installation required, frames are not pre-drilled
- > Available in markerboard white finish only

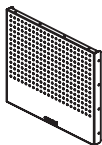

Model	Description	Units Per Ctn	Cubes Each Ctn	Lbs Each Ctn	List Price Ctn
MSTA-EP2420.W	Makerspace, Table, End Panel Kit, 24"w x 20"h	1-Pair	1	21	\$440
MSTA-EP3020.W	Makerspace, Table, End Panel Kit, 30"w x 20"h	1-Pair	1.22	26	\$473
MSTA-EP3620.W	Makerspace, Table, End Panel Kit, 36"w x 20"h	1-Pair	1.47	32	\$506

Lower Shelf Kit

Application & Specification Rules

- > Must be used in conjunction with makerspace end panel kit
- > 16"d shelves used with 24"d tables
12"d shelves used with 30"d tables
14"d shelves used with 36"d tables
- > 16"d shelf standard without back stop
- > Steel construction with full width square steel tube support on front and back sides
- > 12"d and 14"d shelf is standard with a 1.0"h full width back stop
- > Shelves may be installed at the same or different heights with backstop facing in or out
- > Shelves mount directly to Makerspace end panels. End panels allow mounting in 1.0" increments



Model	Description	Units Per Ctn	Cubes Each Ctn	Lbs Each Ctn	List Price Each
MSTA-SL4816.4	Makerspace, Table, Lower Shelf Kit, 48"w x 16"d, Titanium	1 each	0.76	24	\$276
MSTA-SL4816.7	Makerspace, Table, Lower Shelf Kit, 48"w x 16"d, Black	1 each	0.76	24	\$276
MSTA-SL5416.4	Makerspace, Table, Lower Shelf Kit, 54"w x 16"d, Titanium	1 each	0.85	27	\$297
MSTA-SL5416.7	Makerspace, Table, Lower Shelf Kit, 54"w x 16"d, Black	1 each	0.85	27	\$297
MSTA-SL6016.4	Makerspace, Table, Lower Shelf Kit, 60"w x 16"d, Titanium	1 each	0.94	30	\$319
MSTA-SL6016.7	Makerspace, Table, Lower Shelf Kit, 60"w x 16"d, Black	1 each	0.94	30	\$319
MSTA-SL7216.4	Makerspace, Table, Lower Shelf Kit, 72"w x 16"d, Titanium	1 each	1.13	36	\$342
MSTA-SL7216.7	Makerspace, Table, Lower Shelf Kit, 72"w x 16"d, Black	1 each	1.13	36	\$342
MSTA-SL6012.4	Makerspace, Table, Lower Shelf Kit, 60"w x 12"d, Titanium	1-Pair	1.25	40	\$428
MSTA-SL6012.7	Makerspace, Table, Lower Shelf Kit, 60"w x 12"d, Black	1-Pair	1.25	40	\$428
MSTA-SL7212.4	Makerspace, Table, Lower Shelf Kit, 72"w x 12"d, Titanium	1-Pair	1.5	48	\$450
MSTA-SL7212.7	Makerspace, Table, Lower Shelf Kit, 72"w x 12"d, Black	1-Pair	1.5	48	\$450
MSTA-SL7214.4	Makerspace, Table, Lower Shelf Kit, 72"w x 14"d, Titanium	1-Pair	1.9	60	\$472
MSTA-SL7214.7	Makerspace, Table, Lower Shelf Kit, 72"w x 14"d, Black	1-Pair	1.9	60	\$472



Application & Specification Rules

- > Always ships fully cartoned. 1-per carton
- > Height adjustable 25" – 32", 1" increments
- > 1 1/8" core standard
- > 60" and 72" tables standard with 2 grommets. 36" and 48" tables standard with one grommet
- > Double post leg, includes wire management panel field installed

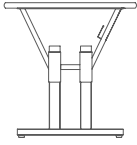

Model	Description	Size	Units Per Ctn	Cubes Each Ctn	Lbs Each Ctn	List Price Each Laminates	List Price Each Premium Markerboard
CY13F	Laminate Flat Edge (F)	24" x 36"	1	4.5	73.0	\$572	\$672
CY14F	Laminate Flat Edge (F)	24" x 48"	1	6.0	88.5	\$619	\$722
CY15F	Laminate Flat Edge (F)	24" x 60"	1	7.4	104.0	\$665	\$791
CY16F	Laminate Flat Edge (F)	24" x 72"	1	8.9	119.7	\$739	\$881
CY03F	Laminate Flat Edge (F)	30" x 36"	1	4.5	90.2	\$582	\$693
CY04F	Laminate Flat Edge (F)	30" x 48"	1	6.0	109.0	\$635	\$749
CY05F	Laminate Flat Edge (F)	30" x 60"	1	7.4	138.0	\$684	\$818
CY06F	Laminate Flat Edge (F)	30" x 72"	1	8.9	155.0	\$761	\$910

Model Builder



Model	1st Option Glide/Caster	2nd Option Frame Color	3rd Option Top Laminate	4th Option Edge Color
	Nylon (3) \$0 Casters (8) \$74	Black (7) \$0 Titanium (4) \$0	See page 65	See page 65
CY14F	3	4	3L	0

Model Example: CY14F.3.7.08.0

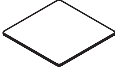

Application & Specification Rules

- > Tops and bases are priced and specified separately
- > Separately specified 3" round grommets available for field installation. See page 87
- > Use two (2) 18" diameter bases for racetrack tops
- > Tops and bases ship in separate cartons, field assembly of tops required
- > 1 1/8" core standard
- > Use a single 24" diameter base for 36" and 42" square or round tops

Model	Description	Size	Units Per Ctn	Cubes Each Ctn	Lbs Each Ctn	List Price Each Laminates	List Price Each Premium Markerboard	
Square								
	DCT-SQ30F	Laminate Flat Edge (F)	30"	1	1.4	31.9	\$221	\$355
	DCT-SQ36F	Laminate Flat Edge (F)	36"	1	3.5	45.5	\$224	\$358
Round								
	DCT-RD30F	Laminate Flat Edge (F)	30"	1	1.8	18.0	\$221	\$355
	DCT-RD36F	Laminate Flat Edge (F)	36"	1	3.3	37.9	\$224	\$358
	DCT-RD42F	Laminate Flat Edge (F)	42"	1	4.5	49.2	\$337	\$471
Racetrack								
	DCT-RT3372F	Laminate Flat Edge (F)	33" x 72"	1	6.0	76.0	\$403	\$570

Model Builder

Model	• 1st Option Top Laminate	• 2nd Option Edge Color
	See page 65	See page 65
DCT-RD30F	• 7M	• 4

Model Example: DCT-RD30F.7M.4



Application & Specification Rules

- > Price is for complete base
- > Bases ship KD with 1- disc base and 1- column in separate boxes, field assembly required
- > Bases and tops are priced, specified and shipped separately
- > Available in 30" table or 42" café heights
- > Disc base includes nylon leveling glides
- > Available in titanium paint finish only
- > Specify one (1) base per round and square tops and two (2) bases for racetrack tops



Model	Size	Disc Base Ctn Cubes Each	Disc Base Ctn Lbs Each	Column Ctn Cubes Each	Column Ctn Lbs Each	List Price Each
Base Assembly 30" Table Height						
DCBR-1830.4	18" dia x 30"h	0.5	14.2	2.8	30.2	\$257
DCBR-2430.4	24" dia x 30"h	0.8	24.5	2.8	30.2	\$315

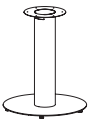

Base Assembly 42" Table Height						
DCBR-1842.4	18" dia x 42"h	0.5	14.2	4.0	41.4	\$304
DCBR-2442.4	24" dia x 42"h	0.8	24.5	4.0	41.4	\$362







Application Guide

	Square Top		Round Top			Racetrack Top
	30"	36"	30"	36"	42"	33" x 72"
30" Table Height	DCBR-1830.4	DCBR-2430.4	DCBR-1830.4	DCBR-2430.4	DCBR-2430.4	DCBR-1830.4
42" Table Height	DCBR-1842.4	DCBR-2442.4	DCBR-1842.4	DCBR-2442.4	DCBR-2442.4	DCBR-1842.4



Application & Specification Rules

- > Always ships fully cartoned; legs included in box
- > 1 1/8" core standard
- > Tops and legs ship in separate cartons
- > Adult 21"-29" legs
- > Specified and priced as a complete table (top & legs)

Model	Top Material Edge	Size	Units Per Ctn	Cubes Each Ctn	Lbs Each Ctn	List Price Each Laminates	List Price Each Premium Markerboard	
Rectangle								
	1206F	Laminate Flat Edge (F)	24" x 36"	1	3.6	42.8	\$208	\$296
	1210F	Laminate Flat Edge (F)	24" x 48"	1	4.4	58.6	\$227	\$334
	1235F	Laminate Flat Edge (F)	24" x 60"	1	5.2	69.5	\$278	\$409
	1246F	Laminate Flat Edge (F)	24" x 72"	1	6.0	79.0	\$305	\$453
	1220F	Laminate Flat Edge (F)	30" x 48"	1	5.2	61.5	\$239	\$358
	1230F	Laminate Flat Edge (F)	30" x 60"	1	6.2	79.4	\$291	\$430
	1250F	Laminate Flat Edge (F)	30" x 72"	1	7.2	98.4	\$326	\$481
	1240F	Laminate Flat Edge (F)	36" x 60"	1	7.2	98.4	\$324	\$492
	1260F	Laminate Flat Edge (F)	36" x 72"	1	8.4	109.4	\$350	\$524
Round								
	1281F	Laminate Flat Edge (F)	42"	1	5.9	65.9	\$280	\$420
	1280F	Laminate Flat Edge (F)	48"	1	7.4	84.3	\$300	\$443
Square								
	1205F	Laminate Flat Edge (F)	36" x 36"	1	4.8	61.3	\$266	\$405
	1215F	Laminate Flat Edge (F)	42" x 42"	1	6.2	78.7	\$276	\$415
	1225F	Laminate Flat Edge (F)	48" x 48"	1	7.7	92.3	\$300	\$443
Half Round								
	1285F	Laminate Flat Edge (F)	48"	1	4.4	51.0	\$225	\$355
Trapezoid								
	1290F	Laminate Flat Edge (F)	30" x 60"	1	5.8	58.1	\$291	\$442
Horseshoe								
	1277F	Laminate Flat Edge (F)	60" x 66"	1	12.1	125.0	\$610	\$867
Kidney								
	1275F	Laminate Flat Edge (F)	48" x 72"	1	10.8	107.0	\$502	\$723

Model Builder



Model	1st Option Glide/Caster	2nd Option Frame Color	3rd Option Top Laminate	4th Option Edge Color
	Nylon (3) \$0	Black (7) \$0 Titanium (4) \$0	See page 65	See page 65
1275F	3	4	8	4

Model Example: 1275F.3.4.8.4



Application & Specification Rules

- > Always ships fully cartoned; legs included in box
- > 11/8" core standard
- > Tops and legs ship in separate cartons
- > Adult 21"-29" legs
- > Specified and priced as a complete table (top & legs)

Model	Top Material Edge	Size	Units Per Ctn	Cubes Each Ctn	Lbs Each Ctn	List Price Each Laminates	List Price Each Premium Markerboard
Clover							
 128CF	Laminate Flat Edge (F)	48"	1	3.2	64.9	\$337	\$481
Flower							
 128FF	Laminate Flat Edge (F)	60"	1	9.1	119.0	\$510	\$790

Model Builder

Model	1st Option Glide/Caster	2nd Option Frame Color	3rd Option Top Laminate	4th Option Edge Color
	Nylon (3) \$0	Black (7) \$0 Titanium (4) \$0	See page 65	See page 65
1275F	3	4	8	4

Model Example: 1275F.3.4.8.4

artcobell



Application & Specification Rules

- > Standard 3/4" MDF with HPL surface and Permatuff Edge (N)
- > UL Listed UL2040 Folding Rollaway Tables
- > Standard with couplings for ganging
- > Markerboard laminates not available

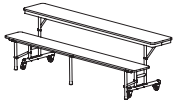

Model	Top Material Edge	Size	Bench Height	Units Per Ctn	Cubes Each Ctn	Lbs Each Ctn	List Price Each Laminates
ABC89PN	Laminate Permatuff Edge (N)	8'w x 29"h	17"	1	30.0	136.0	\$1,654

Model Builder

Model	•	1st Option Frame Color	•	2nd Option Top Laminate	•	3rd Option Bench Laminate
		Titanium (4) Black (7)	\$0 \$0	See page 65		See page 65
ABC89PN	•	4	•	7M	•	7M

Model Example: ABC89PN.4.7M.7M

artcobell

TEACHER STATIONS

Every teacher has her own preference whether it be height-adjustable, traditional sit-down or mobile! We have solutions for every instructor and teaching style.

STATEMENT OF LINE – 82

ARISE – 84

SIT TO STAND – 85

DISCOVER TEACHER DESK – 86

D400/D500 TEACHER DESK – 88

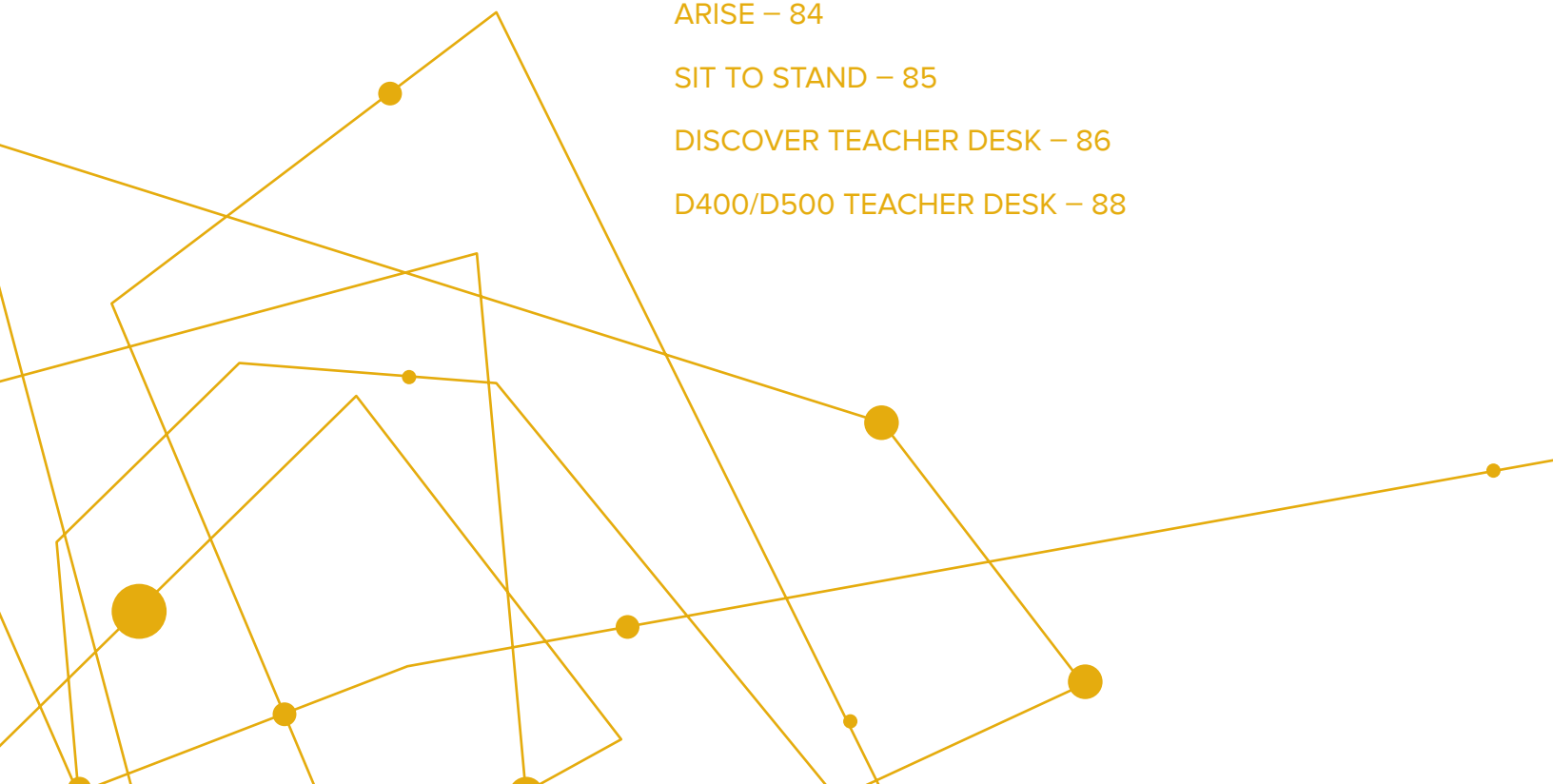

STATEMENT OF LINE

TEACHER WORKSTATIONS



ATPA1

ARISE Podium

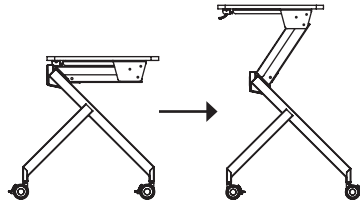

STS-RC2228E

Sit-to-Stand



Rectangular | T-Leg



D-Shape | T-Leg

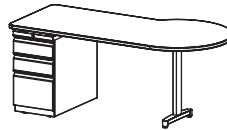

P-Shape | T-Leg

Discover Teacher Desks

(Specified as individual components)

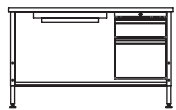

D4R0

D400 Series

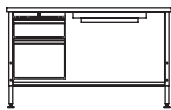

D4L0

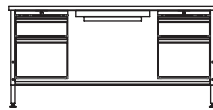

D500HF

D500 Series

Standard Laminates



Premium Markerboard Laminates

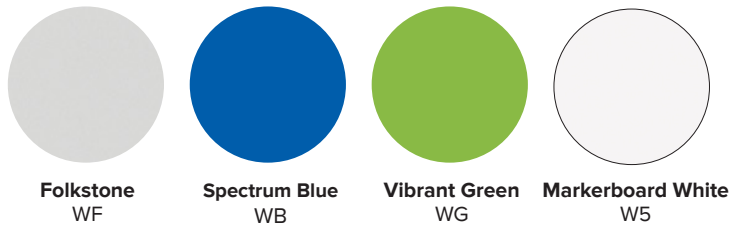

Edge Band

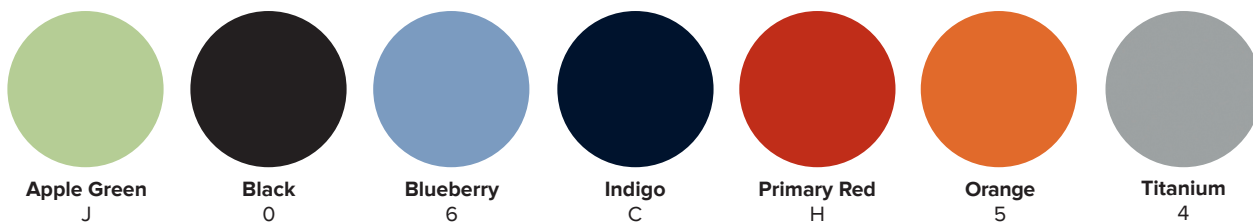

Additional designs available: Most Wilsonart® Laminates are available as special orders. Minimum quantities and extended lead times will apply. Any laminate design that is **not** part of the Artcobell collection shown here will be priced as **premium**.

Due to pattern scale and color variations in computer monitors and printers, we strongly suggest you view actual samples before making surface material selections.



Application & Specification Rules

- > Fully welded base standard with 50mm hard wheel locking casters
 > Unit ships KD, field assembly required
- > Smooth and efficient pneumatic cylinder, one-hand operation
 > Standard in titanium finish
- > Recommended accessories are specified separately and field installed. Tops are not pre-drilled.



Model	Description	Units Per Ctn	Cubes Each Ctn	Lbs Each Ctn	List Price Each Laminates	List Price Each Premium Markerboard
ATPA1F	24" x 36" Top, Banded Flat Edge, Height Adjustable 30.5" - 50.0"	1	7.3	88.0	\$1,559	\$1,659

Model Builder

Model	1st Option Frame Color	2nd Option Top Laminate	3rd Option Edge Color
	Titanium (4) \$0	See page 83 \$0	See page 83
ATPA1F	4	7M	4

Model Example: ATPA1F.4.7M.4

Model	Description	Units Per Ctn	Cubes Each Ctn	Lbs Each Ctn	List Price Each
-------	-------------	---------------	----------------	--------------	-----------------

Wire Book Box, Single Pack



TA-1BBW15	15"w x 13.25"d x 5.25"h, Chrome	1	1.4	4.0	\$73
-----------	---------------------------------	---	-----	-----	------

Perforated Metal Book Box, Single Pack



TA-1BBM16	16"w x 13.22"d x 5.13"h, Titanium	1	1.4	4.8	\$92
TA-1BBM22	21.75"w x 14.25"d x 5.13"h, Titanium	1	1.7	5.9	\$92

Backpack Hook



TA-BPH1	2.25"w x 1.22"d x 2.35"h, Chrome, 1-Pack	1	0.1	0.1	\$14
---------	--	---	-----	-----	------

Grommet



TA-GR3	3" Round Grommet (Black)	1	0.2	<1	\$17
--------	--------------------------	---	-----	----	------

Mobile Pedestal



DPM-BFR.L.4	Box/File, Locking (Titanium)	1	6.0	92.0	\$524
-------------	------------------------------	---	-----	------	-------

artcobell



Sit-to-Stand Desk

Application & Specification Rules

> Always ships fully cartoned, one unit per carton > Ships assembled. Casters are field installed.

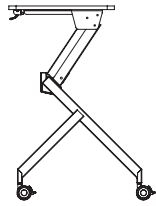
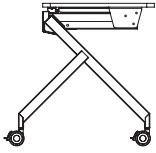

Model	Size	Top Material Edge	Height	Units Per Ctn	Cubes Each	Lbs Each	List Price Each Laminates	List Price Each Premium Markerboard
STS-RC2228E	22"x28"	Laminate 3/4" core Banded Flat Edge (E)	28"-41"	1.0	13.0	54.0	\$1,035	\$1,077

Model Builder

Model	1st Option Frame Color	2nd Option Top Color	3rd Option Edge Color
	Titanium (4) \$0	See page 47	See page 47
STS-RC2228E	4	4E	4

Model Example: STS-RC2228E.4.4E.4

Model	Description	Units Per Ctn	Cubes Each Ctn	Lbs Each Ctn	List Price Each
-------	-------------	---------------	----------------	--------------	-----------------

Wire Book Box, Single Pack

TA-1BBW15	15"w x 13.25"d x 5.25"h, Chrome	1	1.4	4.0	\$73
-----------	---------------------------------	---	-----	-----	------

Perforated Metal Book Box, Single Pack

TA-1BBM16	16"w x 13.22"d x 5.13"h, Titanium	1	1.4	4.8	\$92
TA-1BBM22	21.75"w x 14.25"d x 5.13"h, Titanium	1	1.7	5.9	\$92

Backpack Hook

TA-BPH1	2.25"w x 1.22"d x 2.35"h, Chrome, 1-Pack	1	0.1	0.1	\$14
---------	--	---	-----	-----	------

Grommet

TA-GR3	3" Round Grommet (Black)	1	0.2	<1	\$17
--------	--------------------------	---	-----	----	------

Mobile Pedestal

DPM-BFR.L.4	Box/File, Locking (Titanium)	1	6.0	92.0	\$524
-------------	------------------------------	---	-----	------	-------





Application & Specification Rules

> Specify Top, Pedestal, Leg Kit and Accessories.
All components specified, priced and shipped separately

> Requires field installation of top, pedestal and legs

> To determine left or right, the user needs to be on the short straight edge opposite the bubble. The side the bubble is on from that view will determine left or right.

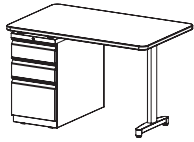

RECTANGLE T-LEG

- (1) DTD-RC3060F Rectangle Top
- (1) DTLK-1TF29 T-Leg Support
- (1) DPF-BBFR Pedestal

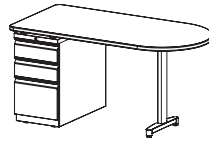

D-SHAPE T-LEG

- (1) DTD-D3060F D-Shape Top
- (1) DTLK-1TF29 T-Leg Support
- (1) DPF-BBFR Pedestal

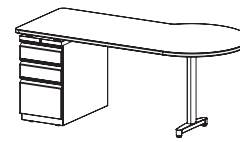

P-SHAPE T-LEG

- (1) DTD-PR3072F Right P-Shape Top
- (1) DTLK-1TF29 T-Leg Support
- (1) DPF-BBFR Pedestal

* Right top displayed

Tops

Model	Size	Units Per Ctn	Cubes Each Ctn	Lbs Each Ctn	List Price Each Laminates	List Price Each Premium Markerboard
Rectangular Top						
DTDT-RC2448F	24"d x 48"w	1	3.7	44.4	\$263	\$366
DTDT-RC2460F	24"d x 60"w	1	4.5	58.9	\$318	\$444
DTDT-RC2472F	24"d x 72"w	1	5.3	69.7	\$355	\$498
DTDT-RC3048F	30"d x 48"w	1	4.5	54.3	\$285	\$400
DTDT-RC3060F	30"d x 60"w	1	5.5	72.6	\$338	\$473
DTDT-RC3072F	30"d x 72"w	1	6.5	90.6	\$377	\$527
D-Shape Top						
DTDT-D3060F	30"d x 60"w	1	5.5	72.6	\$416	\$551
DTDT-D3072F	30"d x 72"w	1	6.5	90.6	\$471	\$621
P-Shape Top						
DTDT-PR3072F	30"d x 72"w, Right	1	7.7	108.2	\$588	\$738
DTDT-PL3072F	30"d x 72"w, Left	1	7.7	108.2	\$588	\$738

Model Builder

Model	Option 1 Top Laminate	Option 2 Edge Color
	See page 83	See page 83
DTDT-RC3072F	7M	4

Model Example: DTDT-RC3072F.7M.4

Leg Supports

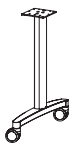

Model	Description	Units Per Ctn	Cubes Each	Lbs Each Unctn	List Price Each
DTLK-1TF29C.4	T-Leg, 1Pk, Casters, Titanium	1	0.9	6.0	\$236

Pedestals

- > File drawer has high sides for front to back filing
- > File drawer includes follower block
- > Box drawer includes pencil tray and drawer divider
- > Standard with lock / keyed alike
- > Drawers feature steel ball-bearing drawer slides
- > Standard with full radius drawer pull

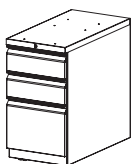

Model	Drawers	Description	Units Per Ctn	Cubes Each Ctn	Lbs Each Ctn	List Price Each
DPF-BBFR.L.4	Box/Box/File	27"h x 15"w x 23"d, Titanium, Casters	1	9.8	90.0	\$776



Barrier Screen

Application & Specification Rules

- > metal bracket can be attached underneath or on top of desks/tables
- > 21" x 24" clear acrylic panel creates a clean barrier between students
- > Priced and sold as four (4) packs only

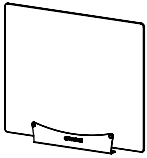

Model	Description	Units Per Ctn	Cubes Each Ctn	Lbs Each Ctn	List Price Ctn
TA-SG2124.C	21" h x 24" w acrylic panel, 4-pack	4-pack		18.2	\$480

Center Drawer

> Field installed only

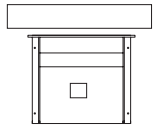

Model	Description	Units Per Ctn	Cubes Each Ctn	Lbs Each Ctn	List Price Each
TA-CD.4	Titanium, 17.26"h x 21.25"w x 3"d	1	1.0	12.0	\$77

Screens

- > 12" h screens may be installed in two positions. Up as a privacy screen (9" h above work surface) or down as a modesty panel (12" below work surface)
- > Clear-frosted acrylic screens, includes brackets and hardware for field installation

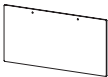

Model	Size	Units Per Ctn	Cubes Each Ctn	Lbs Each Ctn	List Price Each
TA-SA1224.F	12"h x 24"w	1	0.3	4.0	\$175
TA-SA1236.F	12"h x 36"w	1	0.5	5.8	\$261

Grommet

Application & Specification Rules

- > Fits in 3" round hole, field installed
- > Black only, no color specification



Model	Description	Units Per Ctn	Cubes Each Ctn	Lbs Each Ctn	List Price Each
TA-GR3	3" Round Black Only	1	0.2	< 1	\$17

Application Guide | Teacher Desk

Top Shape	Pedestal Configuration	Desk Width	Use Screen Width
Rectangular	Single	48"w	24"w Screen
		60"w	36"w Screen
		72"W	36"w Screen
D-Shape	Single	60"W	24"w Screen
		72"W	36"w Screen
P-Shape	Single	72"W	24"w Screen

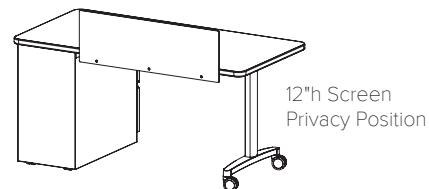
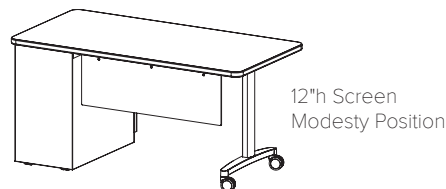



Application & Specification Rules

- > All desks are height adjustable 27" – 36" in 1" increments
- > Fully welded frame and modesty panel
- > Special pallet required for LTL shipping. See note at bottom of page
- > 3" casters must be purchased separately for field installation. Casters extend height range to 38"
- > Specify 3" round grommet separately for field installation. See page 87 (TA-GR3)
- > All pedestals are box/file configuration. Pedestals are standard locking with common key
- > All models standard with non-locking center drawer

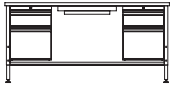

D500HF shown

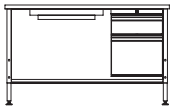

D4R0HF shown

Model	Description	Size	Units Per Ctn	Cubes Each Ctn	Lbs Each Ctn	List Price Each Laminates	List Price Each Premium Markerboard
D500 Series							
D500HF	Double Pedestal, Center Drawer, Flat Edge (F)	30" x 60"	1	29.2	178.0	\$1,407	\$1,543
D400 Series							
D4R0HF	Single Pedestal, RH, Center Drawer, Flat Edge (F)	30" x 48"	1	23.6	147.2	\$1,033	\$1,148
D4L0HF	Single Pedestal, LH, Center Drawer, Flat Edge (F)	30" x 48"	1	23.6	147.2	\$1,033	\$1,148

Model Builder

Model	1st Option Glide/Caster	2nd Option Frame Color	3rd Option Top Laminate	4th Option Edge Color
	Nylon (3) \$0	Black (7) \$0	See page 83	See page 83
D500HF	3	7	3L	0

Model Example: D500HF.3.7.4L.0

Caster Pack

Application & Specification Rules

- > Use with all medium or heavy duty table legs
- > Recommended weight capacity per caster = 125 lbs. (e.g., 2 casters = 250 lb. capacity)
- > Adjustable height table may be used with two (2) or four (4) casters
- > Adjustable height range with casters varies with caster selection



Model	Description	Units Per Ctn	Cubes Ctn	Lbs Ctn	List Price Ctn
TA-CPTD3	Locking 4-Pack 75mm	4	0.1	2	\$74

LTL Carton Information

- > Specify for all LTL shipments
- > One LTL pack required per desk
- > Use for D400 and D500 Series only

Model	Description	List Price Each
SPD4	Use with D4 pre fix models	\$46
SPD5	Use with D5 pre fix models	\$46

STORAGE

Built for heavy duty use. Beautiful and stable, these versatile cabinets work for a wide variety of storage needs.

STATEMENT OF LINE – 90

CABINETS – 92

BOOK SHELVES – 93

MAKERSPACE CABINETS – 94

MAKERSPACE TRAY – 95

MAKERSPACE SHELF/DOOR KITS – 95

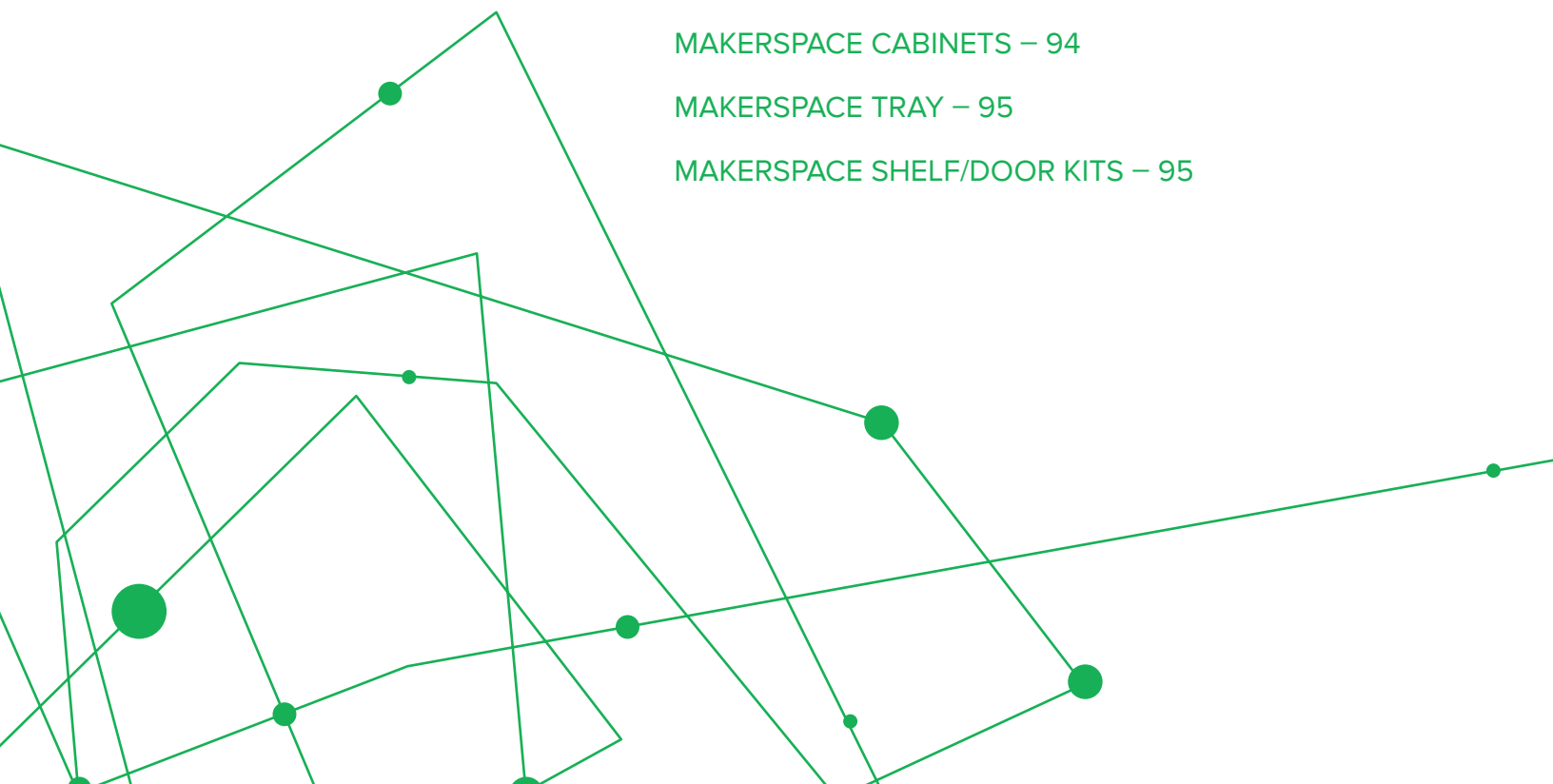

STATEMENT OF LINE

STORAGE

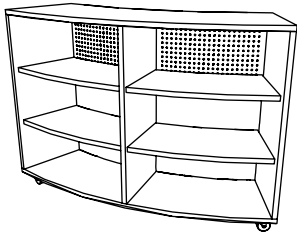

ASFVSC-1742

**Single
Radius Cabinet**



ADFVSC-2042

**Double Face
Radius Cabinet**



ASFVS-1742

**Single
Linear Cabinet**



ADFVS-2042

**Double Face
Linear Cabinet**

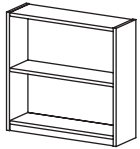

A1236MBC

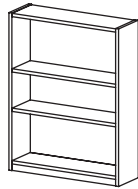

A1248MBC

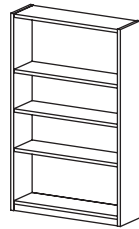

A1260MBC

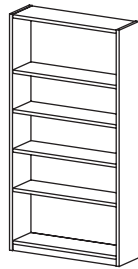

A1272MBC

Book Shelf



MSC-230PX
30"h

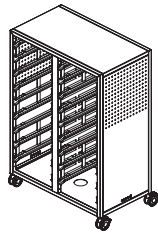

MSC-242PX
42"h

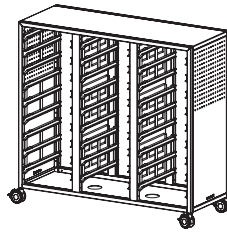

MSC-342PX
42"h

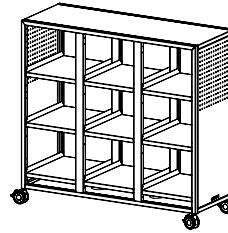

MSC-342PC
42"h

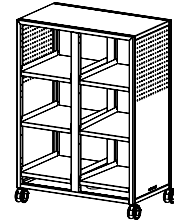

MSC-242PC
42"h

Cabinets

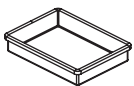

MSCA-TK1203

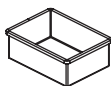

MSCA-TK1206

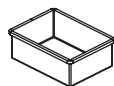

MSCA-TK1212

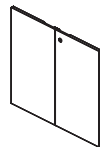

MSCA-DK2303



MSCA-DK2423

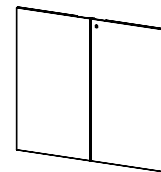

MSCA-DK3423

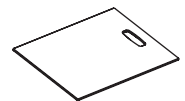

MSCA-SK1216

Tray Kits

Door Kit

Shelf Kit

Standard Laminates (Mobile Cabinets, Bookshelves)



Standard Laminates (Makerspace Door Kit)



Premium Markerboard Laminates

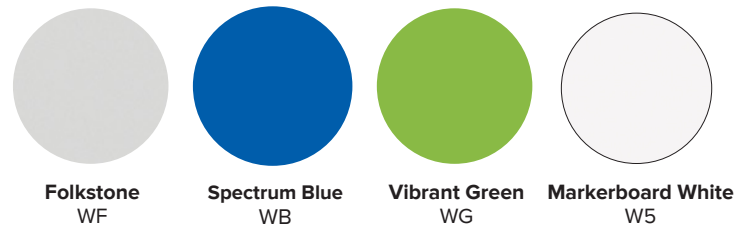





Additional designs available: Most Wilsonart® Laminates are available as special orders. Minimum quantities and extended lead times will apply. Any laminate design that is **not** part of the Artcobell collection shown here will be priced as **premium**.

Due to pattern scale and color variations in computer monitors and printers, we strongly suggest you view actual samples before making surface material selections.

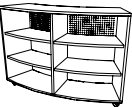

Application & Specification Rules

- > Ships fully cartoned
- > 1" core standard
- > Standard with 75mm casters, 2 of which are locking
- > Due to risk of damage in shipping, mobile cabinets and bookshelves must be shipped as part of a truck-load. They cannot be shipped prepaid LTL.
- > Standard with magnets on the outer side for docking
- > Edge band matches laminate selection
- > Optional perforated back panels available (see models below)
- > Back panels are standard markerboard white paint finish
- > Works with Soft Seating SS-BC18 Curved Bench and SS-RC1842 Rectangle Bench

Base Model	Description	Size	Cubes Each Unctn	Lbs Each Unctn	List Price Each Standard Laminates
Single Face Radius Shelves					
 ASFVSC-1742F	Flat Panel	42"h x 60"w x 17"d	36.5	228.0	\$2,640
ASFVSC-1742P	Perforated Panel	42"h x 60"w x 17"d	36.5	228.0	\$2,667
Double Face Radius Shelves					
 ADFVSC-2042F	Flat Panel	42"h x 60"w x 20"d	42.7	267.0	\$2,913
ADFVSC-2042P	Perforated Panel	42"h x 60"w x 20"d	42.7	267.0	\$2,940
Single Face Linear Shelves					
 ASFVS-1742F	Flat Panel	42"h x 42"w x 17"d	21.3	142.0	\$1,844
ASFVS-1742P	Perforated Panel	42"h x 42"w x 17"d	21.3	142.0	\$1,872
Double Face Linear Shelves					
 ADFVS-2042F	Flat Panel	42"h x 42"w x 20"d	25.8	162	\$2,190
ADFVS-2042P	Perforated Panel	42"h x 42"w x 20"d	25.8	162	\$2,217

Model Builder

Base Model	• 1st Option Laminate
	See page 91
ASFVS-1742F	. 7M

Model Example: ASFVS-1742F.7M

artcobell



Application & Specification Rules

- > Ships fully cartoned
 - > Book shelves are 12”d
 - > Edge band matches laminate selection
- > Due to risk of damage in shipping, mobile cabinets and bookshelves must be shipped as part of a truck-load. They cannot be shipped prepaid LTL.



Base Model	Description	Cubes Each Unctn	Lbs Each Unctn	List Price Each Standard Laminates
------------	-------------	------------------	----------------	------------------------------------

36”h				
A1236MBC	36”h x 37 1/4”w x 12”d	12.1	87.0	\$507

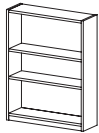

48”h				
A1248MBC	48”h x 37 1/4”w x 12”d	15.9	102.0	\$591

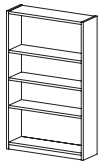

60”h				
A1260MBC	60”h x 37 1/4”w x 12”d	19.8	117.0	\$744



72”h				
A1272MBC	72”h x 37 1/4”w x 12”d	23.6	140.0	\$897

Model Builder





Base Model	•	1st Option Laminate
A1236MBC	•	7M

Model Example: A1236MBC.7M

artcobell

Application & Specification Rules

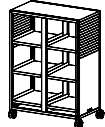
- > Cabinets are available in 30" or 42" heights.
- > Standard with 75mm casters. Casters ship unattached in carton for field installation
- > Side panels are standard with pegboard holes
- > Top and back panels are not perforated
- > All panels are standard markerboard white paint finish
- > Frame is standard in titanium paint finish
- > Bottom panel is standard with a 3" round grommet for power or cord management
- > Cabinets are specified and priced WITHOUT trays or shelves
- > Trays, shelves and other accessories must be specified separately

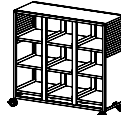
	Model	Description	Units Per Ctn	Cubes Each Ctn	Lbs Each Ctn	List Price Each
	2-Column With Rails, 30" h					
	MSC-230PX.4.W	Pegboard End Panel, w/Rails	1	9.4	92.0	\$1,215
	2-Column with Rails, 42" h					
	MSC-242PX.4.W	Pegboard End Panel, w/Rails	1	13.3	112.0	\$1,350
	2-Column With Cubbies, 42" h					
	MSC-242PC.4.W	Pegboard End Panel, w/Cubbies	1	13.3	147.0	\$1,811
	3-Column With Rails, 42" h					
	MSC-342PX.4.W	Pegboard End Panel, w/Rails	1	21.0	168.0	\$2,027
	3-Column With Cubbies, 42" h					
	MSC-342PC.4.W	Pegboard End Panel, w/Cubbies	1	21.0	220.0	\$2,392

Application & Specification Rules

- > Below are recommendations
- > Shelf can be substituted for 3" tray
- > 1 rail opening for 3" tray or shelf
- > 2 rail openings for 6" tray

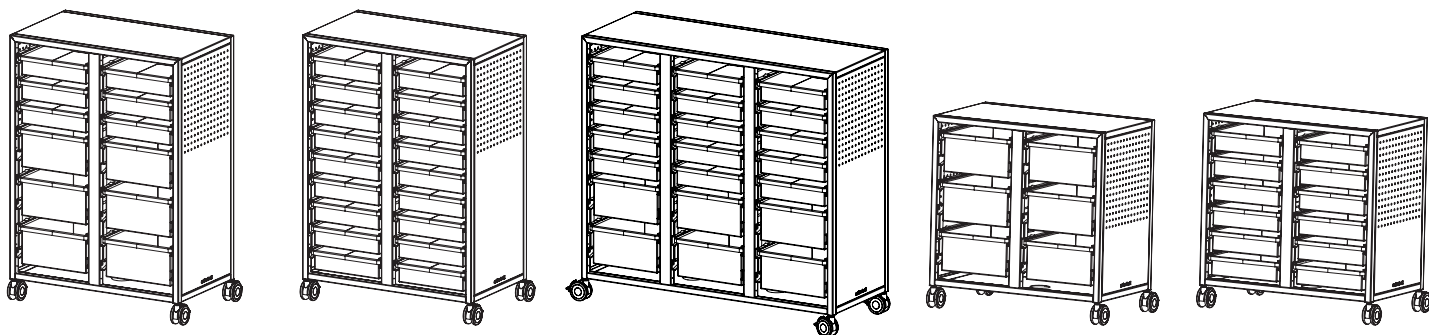

42" Cabinet with Split Trays
Order
QTY 1 – MSC-242PX.4.W
QTY 1 – MSCA-TK1203
QTY 1 – MSCA-TK1206

42" Cabinet with 3" Trays
Order
QTY 1 – MSC-242PX.4.W
QTY 3 – MSCA-TK1203

42" Cabinet with Split Trays
Order
QTY 1 – MSC-342PX.4.W
QTY 3 – MSCA-TK1203
QTY 1 – MSCA-TK1206

30" Cabinet with 6" Trays
Order
QTY 1 – MSC-230PX.4.W
QTY 1 – MSCA-TK1206

30" Cabinet with 3" Trays
Order
QTY 1 – MSC-230PX.4.W
QTY 2 – MSCA-TK1203

Tray Kits

Application & Specification Rules

- > Trays are 16.5"D
- > Trays are priced and specified as kits only. Six (6) trays per kit
- > Trays are standard with integrated front handle

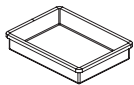

Model	Description	Units Per Ctn	Cubes Each Ctn	Lbs Each Ctn	List Price Each Ctn
MSCA-TK1203.T	Makerspace, Tray Kit, 3"h x 12"w, Translucent, 6-Pack	6 PK	1.6	10.6	\$201
MSCA-TK1206.T	Makerspace, Tray Kit, 6"h x 12"w, Translucent, 6-Pack	6 PK	2.8	14.4	\$312
MSCA-TK1212.T	Makerspace, Tray Kit, 12"h x 12"w, Translucent, 2-Pack	2 PK	2.8	14.4	\$126

Shelf Kit

Application & Specification Rules

- > White Acrylic shelves
 - > Six (6) shelves per kit
 - > Removable. Must lift to remove.
- > Shelf kits are priced and specified as kits only

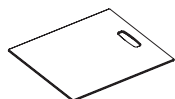

Model	Description	Units Per Ctn	Cubes Each Ctn	Lbs Each Ctn	List Price Ctn
MSCA-SK1216.W	Makerspace, Cabinet, Shelf Kit, 12"w x 16"d, 6-Pack	6 PK	0.43	13	\$428

Door Kit

Application & Specification Rules

- > Laminate surfaces
 - > Specify for 30" or 42" height cabinet
 - > Field installation required
- > Standard locking
- > Titanium painted edge

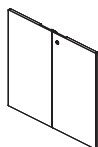

Model	Description	Units Per Ctn	Cubes Each Ctn	Lbs Each Ctn	List Price Each Laminates	List Price Each Premium Markerboard
MSCA-DK230T	Makerspace, Cabinet, RH & LH Door Kit, 2-Column, 30"h	1 pair	0.78	28.0	\$323	\$493
MSCA-DK242T	Makerspace, Cabinet, RH & LH Door Kit, 2-Column, 42"h	1 pair	1.11	36.0	\$374	\$544
MSCA-DK342T	Makerspace, Cabinet, RH & LH Door Kit, 3-Column, 42"h	1 pair	1.70	54.0	\$561	\$768

Model Builder

Model	•	1st Option Door Color
		See page 91
MSCA-DK230T	•	7M

Model Example: MSCA-DK230T.7M

artcobell

PROJECT

Large projects often include products that are not a part of the normal Artcobell production schedule. However, these products may still be needed to complete a project or fill a unique customer requirement. Many of those products are found in the Project Section of the price list. While Artcobell has the ability to manufacture the products in the Project Section, those products may require minimum quantities and/or longer lead times. Please contact Artcobell Sales or Customer Service before specifying, bidding, quoting or selling any product in the Project Section.

STATEMENT OF LINE – 97

UNIFLEX SEATING – 110

ALPHABET SEATING – 102

STUDENT DESKS – 114

DISCOVER SEATING – 106

T-LEG TABLES – 117

STATEMENT OF LINE

PROJECT

ALPHABET SEATING

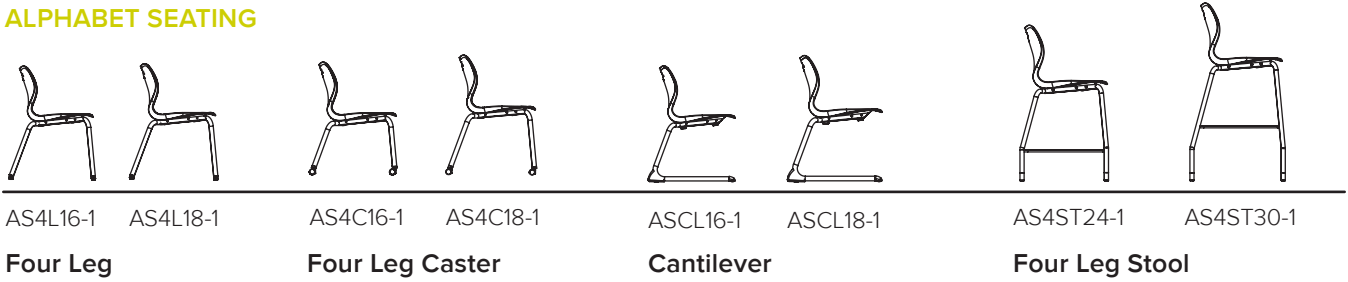

AS4L16-1 AS4L18-1 AS4C16-1 AS4C18-1 ASCL16-1 ASCL18-1 AS4ST24-1 AS4ST30-1

Four Leg **Four Leg Caster** **Cantilever** **Four Leg Stool**

DISCOVER SEATING



ASTA18 -1 ASST18-1 D10A-1 D10X-1 D16A-1 D16X-1 D109-1 D15A-1

Task Chair **Swivel Stool** **Four Leg Stacking Chair**



D30A-1 DP9A-1 DP9X-1 DL9A-1 DL9X-1 D99A-1 D99X-1

Cantilever Chair **Task Chair** **Swivel Stool** **Four Leg Swivel Stool**

UNIFLEX SEATING



7107-1 7108-1 7167 7168 7168-1 7157-1 7P90-1 7P98 | 7P98-1 7L90-1 7L98 | 7L98-1

Four Leg Stacking Chair **Task Chair** **Swivel Stool**

STATEMENT OF LINE

PROJECT



7990 | 7990-1

Four Leg Swivel Stool



DAJ6

Open Front Poly Box



7SD4F300



7SD4F306



7SD3F30



7SD4F30T

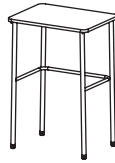

7SD4F420

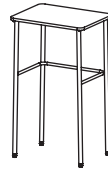

7SD4F426

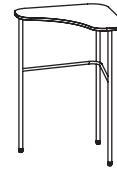

7SD3F42

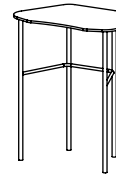

7SD4F42T

7SD Series



D85A | D85X

Sled Combo Desks



Rectangle



Expanse

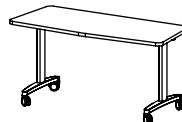

Chevron



Half-Round

T-Leg Tables | Nesting

T-Leg Table | Fixed

Standard Laminates



Fusion Maple
7M



New Age Oak
3L



Pinnacle Walnut
F9



French Pear
H4



Crisp Linen
4E

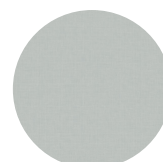

Nordic Linen
C9

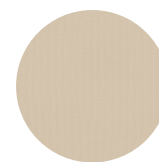

Flax Linen
5T

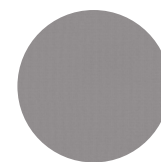

Pressed Linen
5S



Kingswood Walnut
NB



High Rise
3E

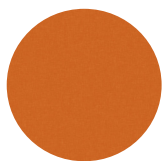

Marmalade
J1

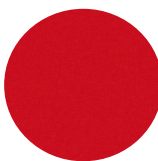

Berry
J8

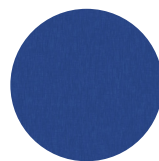

Blue Curacao
N3

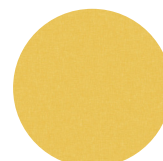

Quince
N1

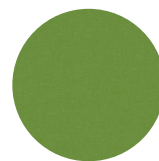

Dublin Crossweave
N5

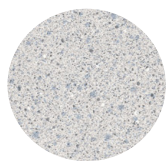

Grey Glace
18



Nepal Teak
72



Bannister Oak
08

Premium Markerboard Laminates



Folkstone
WF

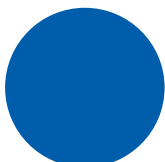

Spectrum Blue
WB



Vibrant Green
WG

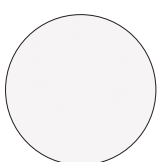

Markerboard White
W5

Edge Band

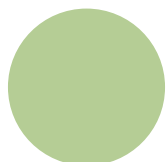

Apple Green
J

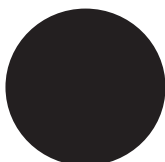

Black
0

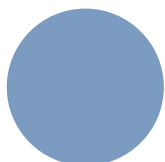

Blueberry
6

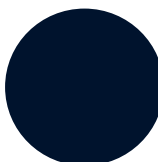

Indigo
C

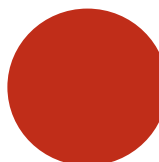

Primary Red
H

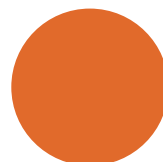

Orange
5

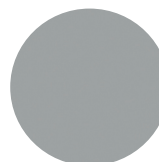

Titanium
4

Additional designs available: Most Wilsonart® Laminates are available as special orders. Minimum quantities and extended lead times will apply. Any laminate design that is **not** part of the Artcobell collection shown here will be priced as **premium**.

Due to pattern scale and color variations in computer monitors and printers, we strongly suggest you view actual samples before making surface material selections.

Uncoated (Standard) - Seat Pads Alphabet, Discover, Uniflex

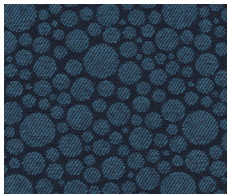

Aquarius
A

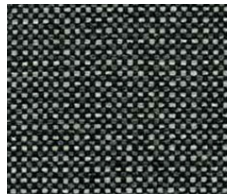

Black Marble
M

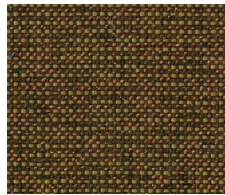

Bonsai
H

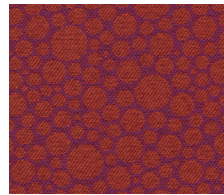

Clown
N

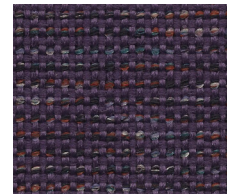

Concord
J

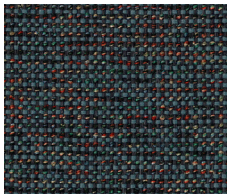

Federal Blue
E

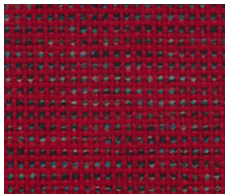

Scarlet
S

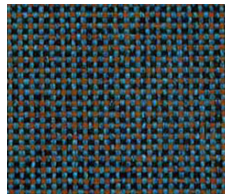

Titan Blue
T

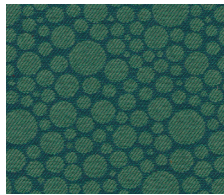

Whirlpool
P

Coated (Premium) - Silvertex (R) Vinyl

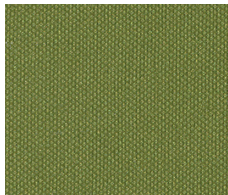

Basil
S02

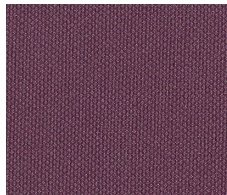

Blackberry
S04

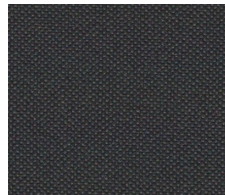

Carbon
S08

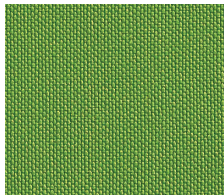

Crème De Menthe
S13



Imperial
S15



Limoncello
S18

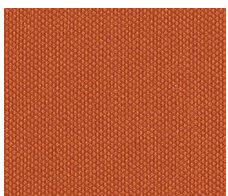

Mandarin
S20

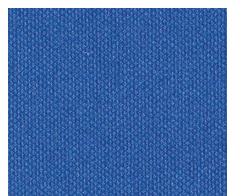

Marine
S21

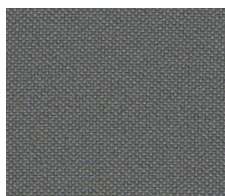

Sterling
S32



Taupe
S34

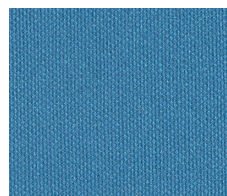

Turquoise
S35

Additional fabrics available through the Momentum 5-Click program. To view options and order samples go to www.momtexas.com/mfg/315

- Absecon Mills fabric = Standard Pricing
- Silvertex Standards = \$30 upcharge per seat pad
- Momentum Grade 1 and 2 = \$50 upcharge per seat pad

Due to pattern scale and color variations in computer monitors and printers, we strongly suggest you view actual samples before making surface material selections.

Poly

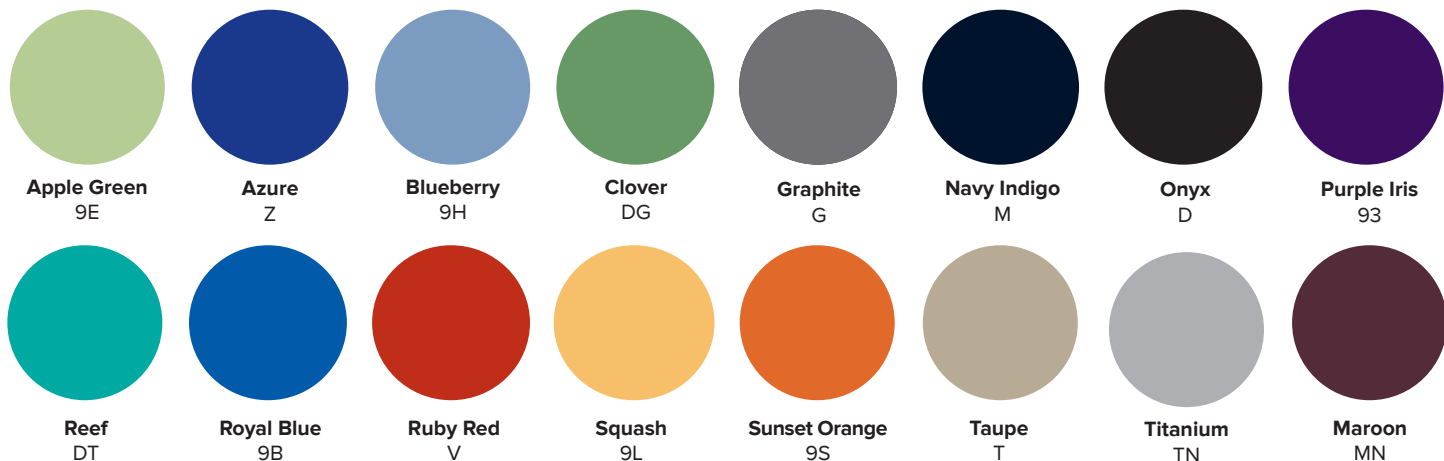

Solid Plastic



Metal Frames

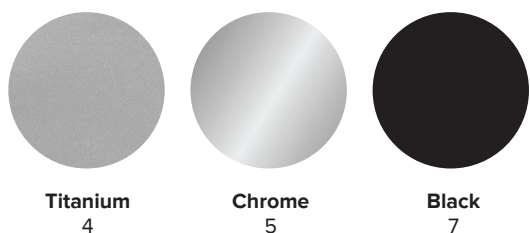

Due to pattern scale and color variations in computer monitors and printers, we strongly suggest you view actual samples before making surface material selections.



Four Leg Chair with Seat Pad

Application & Specification Rules

> Always ships fully cartoned.

> Must order in multiples of 4 (full carton quantity)

> Chairs stack four (4) high.



Model	Description	Seat Height	Units Per Ctn	Cubes Each	Lbs Each	List Price Each
AS4L16-1	Seat Pad	16"	4	3.8	13.1	\$237
AS4L18-1	Seat Pad	18"	4	3.8	13.6	\$237

Model Builder

Model	1st Option Glide	2nd Option Frame Color	3rd Option Shell Color	4th Option Fabric Color
	Nylon (3) \$0 Steel (1) \$0 Non-Skid (2) \$8 Felt (F) \$8 Boot Indigo (M) \$8 Onyx (D) \$8 Graphite (G) \$8 Ruby Red (V) \$8	Chrome (5) \$0 Titanium (4) \$0 Black (7) \$0	See page 101	See page 100 Standard \$0 Silvertex standards \$30 Momentum Grade 1 and 2 \$50
AS4L16-1	3	4	M	T

Model Example: AS4L16-1.3.4.M.T



Four Leg Caster Chair

Application & Specification Rules

> Always ships fully cartoned

> Must order poly shells in multiples of 4 (full carton quantities)



Model	Description	Seat Height	Units Per Ctn	Cubes Each	Lbs Each	List Price Each
AS4C16-1	Seat Pad	16"	4	3.8	14.3	\$271
AS4C18-1	Seat Pad	18"	4	3.8	14.8	\$271

Model Builder

Model	1st Option Glide	2nd Option Frame Color	3rd Option Shell Color	4th Option Fabric Color
	Hardwheel (H) \$0	Chrome (5) \$0 Titanium (4) \$0 Black (7) \$0	See page 101	See page 100 Standard \$0 Silververtex standards \$30 Momentum Grade 1 and 2 \$50
AS4C16-1	H	4	93	J

Model Example: AS4C16-1.H.4.93.J

Cantilever Chair

Application & Specification Rules

> Always ships fully cartoned.

> Must order poly shells in multiples of 4 (full carton quantities)



Model	Description	Seat Height	Units Per Ctn	Cubes Each	Lbs Each	List Price Each
ASCL16-1	Seat Pad	16"	4	3.8	16.6	\$269
ASCL18-1	Seat Pad	18"	4	3.8	17.2	\$269

Model Builder

Model	1st Option Glide	2nd Option Frame Color	3rd Option Shell Color	4th Option Fabric Color
	Nylon (3) \$0 Steel (1) \$0 Felt (F) \$8 Non-Skid (2) \$8	Chrome (5) \$0 Titanium (4) \$0 Black (7) \$0	See page 101	See page 100 Standard \$0 Silververtex standards \$30 Momentum Grade 1 and 2 \$50 Specify ONLY with -1 Models.
ASCL16-1	3	4	93	J

Model Example: ASCL16-1.3.4.93.J

artcobell



Application & Specification Rules

> Always ships fully cartoned.

> Standard with nylon solo glide.

> Standard with welded foot rest



Model	Description	Seat Height	Units Per Ctn	Cubes Each	Lbs Each	List Price Each
AS4ST24-1	Seat Pad	24"	1	9.0	32.6	\$324
AS4ST30-1	Seat Pad	30"	1	11.5	34.6	\$331

Model Builder

Model	1st Option Glide	2nd Option Frame Color	3rd Option Shell Color	4th Option Fabric Color
	Solo Nylon (P) \$0	Chrome (5) \$0 Titanium (4) \$0 Black (7) \$0	See page 101	See page 100 Standard Silvertex standards \$0 Momentum Grade 1 and 2 \$30 \$50
AS4ST24-1	P	4	93	J

Model Example: AS4ST24-1.P.4.93.J

artcobell



Application & Specification Rules

- > Always ship fully cartoned, one unit per carton
- > Standard with five-star base with swivel and
- > Lab stool includes 18" diameter metal foot ring. 10" adjustment range. 8" to 18" from floor.
- > Stool includes height adjustable 18" diameter foot ring
- > Black base only, no color specification required



Model	Description	Seat Height	Units Per Ctn	Cubes Each Ctn	Lbs Each Ctn	List Price Each
Task Chair						
ASTA18-1	Poly Shell with Seat Pad	16" - 21"	1	6.2	23.5	\$354



Swivel Stool						
ASST18-1	Poly Shell with Seat Pad	22" - 32"	1	6.2	28.0	\$405

Model Builder

Model	1st Option Caster/Glide	2nd Option Shell Color	3rd Option Fabric Color
	Hard wheel Caster (H) \$0 Bell Glide (B) \$0	See page 101	See page 100 Standard \$0 Silververtex standards \$30 Momentum Grade 1 and 2 \$50
ASTA18-1	H	M	S

Model Example with Pad: ASTA18-1.H.M.S

artcobell



Application & Specification Rules

- > Four leg and caster chairs ship without cartons on truckloads
- > Four leg chairs stack to 10 high. Caster chairs stack 4 high
- > Bookrack chairs always ship fully cartoned
- > Bookrack chairs must be ordered in multiples of 2 (full carton quantities)



Model	Description	Seat Height	Cubes Each Unctn	Lbs Each Unctn	List Price Each
D10A-1	Seat Pad	18"	1.5	9.5	\$158
D10X-1	Seat Pad	18"	1.6	13.0	\$173



With Casters					
D16A-1	Seat Pad	18"	1.5	12.8	\$214
D16X-1	Seat Pad	18"	1.6	14.4	\$228



Music Chair - Band Pitch					
D109-1	Seat Pad	18"	1.5	9.5	\$182

With Book Rack - Always Ships Fully Cartoned



Model	Description	Seat Height	Chairs Per Ctn	Cubes Each Ctn	Lbs Each Ctn	List Price Each
D15A-1	Seat Pad	18"	2	5.9	15.0	\$232

Model Builder

Model	1st Option Glide	2nd Option Frame Color	3rd Option Shell Color	4th Option Fabric Color
	Nylon (3) \$0 Steel (1) \$0 Non-Skid (2) \$8 Felt (F) \$8 Boot Indigo (M) \$8 Onyx (D) \$8 Graphite (G) \$8 Ruby Red (V) \$8	Chrome (5) \$0 Titanium (4) \$0 Black (7) \$0	See page 101	See page 100 Standard \$0 Silvertex standards \$30 Momentum Grade 1 and 2 \$50
D10A-1	3	4	M	T

Model Example with Pad: D10A-1.3.4.M.T

artcobell



Application & Specification Rules

- > NOTE MODELS ARE FOR CARTON QUANTITIES
- > Chairs stack to 10 high, caster chairs stack 4 high
- > By ordering a quantity of one (1) you will receive 5 chairs
- > Carton pack models for LTL Shipments
- > Carton Pack models are priced and sold as 5-packs only



Model	Description	Seat Height	Chairs Per Ctn	Cubes Ctn	Lbs Ctn	List Price Ctn
D10AC-1	Seat Pad, 5-Chairs, Fully Cartoned	18"	5	13.2	58.5	\$808
D10XC-1	Seat Pad, 5-Chairs, Fully Cartoned	18"	5	19.0	72.5	\$895



With Casters						
D16AC-1	Seat Pad, 4-Chairs, Fully Cartoned	18"	4	13.2	57.3	\$874
D16XC-1	Seat Pad, 4-Chairs, Fully Cartoned	18"	4	19.0	65.7	\$942



Music Chair						
D109C-1	Seat Pad, 5-Chairs, Fully Cartoned	18"	5	13.2	57.5	\$928

Model Builder

Model	1st Option Glide	2nd Option Frame Color	3rd Option Shell Color	4th Option Fabric Color
	Nylon (3) \$0 Steel (1) \$0 Non-Skid (2) \$40 (\$8 per chair) Felt (F) \$40 (\$8 per chair) Boot Indigo (M) \$40 (\$8 per chair) Onyx (D) \$40 (\$8 per chair) Graphite (G) \$40 (\$8 per chair) Ruby Red (V) \$40 (\$8 per chair)	Chrome (5) \$0 Titanium (4) \$0 Black (7) \$0	See page 101	See page 100 Standard \$0 Silvertex standards \$30 Momentum Grade 1 and 2 \$50
D10AC-1	3	4	M	T

Model Example With Pad: D10AC-1.3.4.M.T

artcobell



Application & Specification Rules

> Always ships fully cartoned

> Must order in multiples of 4 (full carton quantity)

> Chairs stack 4 high



Model	Description	Seat Height	Units Per Ctn	Cubes Each	Lbs Each	List Price Each
D30A-1	Seat Pad	18"	4	3.9	16.1	\$233

Model Builder

Model	1st Option Glide	2nd Option Frame Color	3rd Option Shell Color	4th Option Fabric Color
	Nylon (3) \$0 Steel (1) \$0 Non-Skid (2) \$8 Felt (F) \$8	Chrome (5) \$0	See page 101	See page 100 Standard \$0 Silvertex standards \$30 Momentum Grade 1 and 2 \$50
D30A-1	3	5	9H	M

Model Example: D30A-1.3.5.9H.M

artcobell



Task Chair & Swivel Stool

Application & Specification Rules

- > Always ship fully cartoned, one unit per carton
- > Available with hard-wheel caster or bell glides
- > Five-star base, black only
- > Pneumatic height adjustment.
- > Lab stool includes 18" diameter metal foot ring. 10" adjustment range, 8" to 18" from floor



Model	Description	Seat Height	Units Per Ctn	Cubes Each	Lbs Each	List Price Each
Task Chair						
DP9A-1	Seat Pad, A shell size	17" - 22"	1	6.2	22.9	\$300
DP9X-1	Seat Pad, A+ shell size	17" - 22"	1	6.2	24.1	\$328
Swivel Stool						
DL9A-1	Seat Pad, A shell size	24" - 34"	1	6.2	29.6	\$328
DL9X-1	Seat Pad, A+ shell size	24" - 34"	1	6.2	30.8	\$356

Model Builder

Base	1st Option Caster/Glide	2nd Option Shell Color	3rd Option Fabric Color
	Hard wheel Caster (H) \$0 Bell Glide (B) \$0	See page 101	See page 100 Standard \$0 Silververtex standards \$30 Momentum Grade 1 and 2 \$50
DP9A-1	H	M	S

Model Example: DP9A-1.H.M.S

Four Leg Swivel Stool

Application & Specification Rules

- > Always ships fully cartoned
- > Must order in multiples of 2 (full carton quantity)
- > Include foot rest, non-adjustable
- > Seat swivels 360-degrees



Model	Description	Seat Height	Units Per Ctn	Cubes Each	Lbs Each	List Price Each
D99A-1	Seat Pad, A shell size	25" - 33"	2	5.0	23.3	\$331
D99X-1	Seat Pad, A+ shell size	25" - 33"	2	5.0	24.0	\$349

Model Builder

Model	1st Option Caster/Glide	2nd Option Frame Color	3rd Option Shell Color	4th Option Fabric Color
	Nylon (3) \$0 Steel (1) \$0 Non-Skid (2) \$8 Felt (F) \$8 Boot Indigo (M) \$8 Onyx (D) \$8 Graphite (G) \$8 Ruby Red (V) \$8	Chrome (5) \$0 Black (7) \$0 Titanium (4) \$0	See page 101	See page 100 Standard \$0 Silververtex standards \$30 Momentum Grade 1 and 2 \$50
D99A-1	1	5	M	S

Model Example: D99A-11.5.M.S



Application & Specification Rules

- > Four leg and caster chairs ship without cartons on truckloads
- > ONLY 7176 models available with 50mm dual wheel casters.
- > Four leg chairs stack to 10 high. Caster chairs stack 4 high
- > Bookrack chairs must be ordered in multiples of 2 (full carton quantities)
- > Bookrack chairs always ship fully cartoned



Model	Description	Seat Height	Cubes Each Unctn	Lbs Each Unctn	List Price Each
7107-1	Seat Pad	17.5"	1.3	9.8	\$154
7108-1	Seat Pad	18.5"	1.3	11.7	\$165



With Casters					
Model	Description	Seat Height	Cubes Each Unctn	Lbs Each Unctn	List Price Each
7167-1	Seat Pad	17.5"	1.2	12.0	\$208
7168		18.5"	1.3	12.9	\$145
7168-1	Seat Pad	18.5"	1.3	13.5	\$221

With Bookrack - Always Ships Fully Cartoned



Model	Description	Seat Height	Chairs Per Ctn	Cubes Each Chair	Lbs Each Chair	List Price Each
7157-1	Seat Pad	17.5"	2	4.8	12.0	\$222

Model Builder

Model	1st Option Glide	2nd Option Frame Color	3rd Option Shell Color	4th Option Fabric Color
	Nylon (3) \$0 Steel (1) \$0 Non-Skid (2) \$8 Felt (F) \$8 Boot Indigo (M) \$8 Onyx (D) \$8 Graphite (G) \$8 Ruby Red (V) \$8	Chrome (5) \$0 Titanium (4) \$0 Black (7) \$0	See page 101	See page 100 Standard \$0 Silvertex standards \$30 Momentum Grade 1 and 2 \$50 Specify ONLY with -1 Models.
7168	H	4	M	T

Model Example without Pad: 7168.H.4.M
 Model Example with Pad: 7168-1.H.4.M.T



Application & Specification Rules

- > NOTE MODELS ARE FOR CARTON QUANTITIES
- > All chairs stack to 10 high
- > Carton pack models are priced and sold as 5 packs or 6 packs only (model dependent)
- > Carton pack models for LTL shipments
- > ONLY 7176 models available with 50mm dual wheel casters.
- > By ordering a quantity of one (1) you will receive 5-6 chairs (model dependent)



Model	Description	Seat Height	Chairs Per Ctn	Cubes Each Ctn	Lbs Each Ctn	List Price Ctn
7107C-1	Seat Pad, 5-Chairs, Fully Cartoned	17.5"	5	13.2	54.5	\$788
7108C-1	Seat Pad, 5-Chairs, Fully Cartoned	18.5"	5	13.2	63.6	\$855



With Casters						
Model	Description	Seat Height	Chairs Per Ctn	Cubes Each Ctn	Lbs Each Ctn	List Price Ctn
7167C-1	Seat Pad, 5-Chairs, Fully Cartoned	17.5"	5	13.2	64.5	\$1,058
7168C	5-Chairs, Fully Cartoned	18.5"	5	13.2	70.6	\$755
7168C-1	Seat Pad, 5-Chairs, Fully Cartoned	18.5"	5	13.2	73.6	\$1,135

Model Builder

Model	1st Option Glide	2nd Option Frame Color	3rd Option Shell Color	4th Option Fabric Color
	Nylon (3) \$0 Steel (1) \$0 Non-Skid (2) \$40 (\$8 per chair) Felt (F) \$40 (\$8 per chair) Boot Indigo (M) \$40 (\$8 per chair) Onyx (D) \$40 (\$8 per chair) Graphite (G) \$40 (\$8 per chair) Ruby Red (V) \$40 (\$8 per chair)	Chrome (5) \$0 Titanium (4) \$0 Black (7) \$0	See page 101	See page 100 Standard \$0 Silvertex standards \$30 Momentum Grade 1 and 2 \$50 Specify ONLY with -1 Models.
7167C-1	3	4	M	T

Model Example without Pad: 7168C.3.4.M
 Model Example with Pad: 7167C-1.3.4.M.T



Application & Specification Rules

> Always ships fully cartoned, one unit per carton

> Lab stool includes 18" diameter metal foot ring. 10" adjustment range, 8" to 18" from floor

> Five-star base, black only



Model	Description	Seat Height	Units Per Ctn	Cubes Each	Lbs Each	List Price Each
Task Chair						
7P90-1	Seat Pad, A Shell	16.25" - 20.75"	1	6.2	18.6	\$289
7P98	A+ Shell	16.25" - 20.75"	1	6.2	19.0	\$236
7P98-1	Seat Pad	16.25" - 20.75"	1	6.2	19.6	\$311
Swivel Stool						
7L90-1	Seat Pad, A Shell	23" - 33"	1	6.2	25.3	\$317
7L98	A+ Shell	23" - 33"	1	6.2	25.7	\$265
7L98-1	Seat Pad, A+ Shell	23" - 33"	1	6.2	26.3	\$341

Model Builder

Model	1st Option Caster/Glide	2nd Option Shell Color	3rd Option Fabric Color
	Hard wheel Caster (H) \$0 Bell Glide (B) \$0	See page 101	See page 100 Standard \$0 Silvertex standards \$30 Momentum Grade 1 and 2 \$50 Specify ONLY with -1 Models.
7L98	H	M	

Model Example without Pad: 7L98.H.M

Model Example with Pad: 7L90-1.B.M.T



Application & Specification Rules

- > Always ships fully cartoned, one unit per carton
- > Must order in multiples of 2 (full carton quantity)
- > Include foot rest, non-adjustable
- > Seat swivels 360-degrees



Model	Description	Seat Height	Units Per Ctn	Cubes Each	Lbs Each	List Price Each
7990		23" - 31"	2	5.0	19.0	\$228
7990-1	Seat Pad	23" - 31"	2	5.0	19.6	\$304

Model Builder

Model	• 1st Option Caster/Glide	• 2nd Option Frame Color	• 3rd Option Shell Color	• 4th Option Fabric Color
	Nylon (3) \$0	Chrome (5) \$0 Black (7) \$0 Titanium (4) \$0	See page 101	See page 100 Standard \$0 Silververtex standards \$30 Momentum Grade 1 and 2 \$50 Specify ONLY with -1 Models.
7990	• 3	• 5	• D	•

Model Example without Pad: 7990.3.5.D
 Model Example with Pad: 7990-1.3.5.D.M



Application & Specification Rules

- > Always ships fully cartoned, two units per carton
 - > Must order in multiples of 2 (full carton quantity)
- > 3/4" core standard
 - > Ships KD, field installation of legs required
- > Jumbo-sized fully integrated polypropylene book box
 - > When selecting a markerboard laminate, you must specify Model with banded flat edge (E)



Model	Top Size	Top Material Edge	Height	Units Per Ctn	Cubes Each	Lbs Each	List Price Each Laminates	List Price Each Premium Markerboard
DAJ63	20" x 26"	Laminate Clear Edge (3)	22"-30"	2	2.7	24.5	\$145	N/A
DAJ6E	20" x 26"	Laminate Banded Flat Edge (E)	22"-30"	2	2.7	24.5	\$179	\$220

Model Builder

Model	•	1st Option Glide	•	2nd Option Frame Color	•	3rd Option Book Box Color	•	4th Option Top Color	•	5th Option Edge Color
		Nylon (3)		Black (7) \$0 Titanium (4) \$0 Chrome (5) \$0		See page 101		See page 101		See page 99
DAJ6E	•	3	•	4	•	V	•	7M	•	H

Model Example: DAJ6E.3.5.V.7M.H



Application & Specification Rules

- > Always ships fully cartoned, two units per carton
- > Accommodates a variety of book box and back-pack hook accessories. See page 58
- > When selecting a markerboard laminate, you must specify Model with banded flat edge (E)
- > Must order in multiples of 2 (full carton quantity)
- > Accessories are specified and priced separately. All accessories are field installed



Four Leg Student Desk | Rectangle 18" x 24"

Model	Top Material Edge	Height	Units Per Ctn	Cubes Each	Lbs Each	List Price Each Laminates	List Price Each Premium Markerboard
7SD4F3003	Laminate Clear Edge (3)	Fixed, 30"	2	4.9	20.0	\$136	N/A
7SD4F300E	Laminate Banded Flat Edge (E)	Fixed, 30"	2	4.9	20.0	\$169	\$208
7SD4F300S	Solid Plastic (S)	Fixed, 30"	2	4.9	22.0	\$199	N/A
7SD4F4203	Laminate Clear Edge (3)	Fixed, 42"	2	6.8	26.0	\$186	N/A
7SD4F420E	Laminate Banded Flat Edge (E)	Fixed, 42"	2	6.8	26.0	\$219	\$258
7SD4F420S	Solid Plastic (S)	Fixed, 42"	2	6.8	28.0	\$249	N/A



Four Leg Student Desk | Rectangle 20" x 26"

7SD4F3063	Laminate Clear Edge (3)	Fixed, 30"	2	5.5	21.0	\$168	N/A
7SD4F306E	Laminate Banded Flat Edge (E)	Fixed, 30"	2	5.5	21.0	\$202	\$243
7SD4F306S	Solid Plastic (S)	Fixed, 30"	2	5.5	23.0	\$239	N/A
7SD4F4263	Laminate Clear Edge (3)	Fixed, 42"	2	6.8	27.0	\$217	N/A
7SD4F426E	Laminate Banded Flat Edge (E)	Fixed, 42"	2	6.8	27.0	\$252	\$293
7SD4F426S	Solid Plastic (S)	Fixed, 42"	2	6.8	29.0	\$289	N/A



Tri-Top | 28" x 28"

7SD3F303	Laminate Clear Edge (3)	Fixed, 30"	2	7.4	24.0	\$173	N/A
7SD3F30E	Laminate Banded Flat Edge (E)	Fixed, 30"	2	7.4	24.0	\$211	\$255
7SD3F30S	Solid Plastic (S)	Fixed, 30"	2	7.4	26.0	\$283	N/A
7SD3F423	Laminate Clear Edge (3)	Fixed, 42"	2	10.6	26.0	\$223	N/A
7SD3F42E	Laminate Banded Flat Edge (E)	Fixed, 42"	2	10.6	26.0	\$260	\$304
7SD3F42S	Solid Plastic (S)	Fixed, 42"	2	10.6	28.0	\$333	N/A



Trapezoid | 20" x 32"

7SD4F30T3	Laminate Clear Edge (3)	Fixed, 30"	2	7.3	25.0	\$180	N/A
7SD4F30TE	Laminate Banded Flat Edge (E)	Fixed, 30"	2	7.3	25.0	\$219	\$263
7SD4F42T3	Laminate Clear Edge (3)	Fixed, 42"	2	10.5	27.0	\$230	N/A
7SD4F42TE	Laminate Banded Flat Edge (E)	Fixed, 42"	2	10.5	27.0	\$268	\$312

Model Builder

Model	1st Option Glide	2nd Option Frame Color	3rd Option Top Color	4th Option Edge Color
	Nylon (3)	Black (7) \$0 Titanium (4) \$0 Chrome (5) \$0	See pages 99 + 101	See page 99
7SD4F3003	3	4	7M	

Model Example with Solid Plastic Top: 7SD4A03.3.4.7M

Model Example with Premium Markerboard: 7SD4F30TE.3.4.W5.4



Application & Specification Rules

- > Always ships fully cartoned, two units per carton
- > Standard with fixed wire book rack
- > Standard without glides
- > Must order in multiples of 2 (full carton quantities)



Model	Top Size	Top Material Edge	Height	Units Per Ctn	Cubes Each	Lbs Each	List Price Laminates Each
D85A3	18" x 24"	Laminate Clear Edge (3)	18"	2	9.8	43.9	\$366
D85AS	18" x 24"	Solid Plastic (S)	18"	2	9.8	47.9	\$429
D85X3	18" x 24"	Laminate Clear Edge (3)	18"	2	11.5	44.8	\$404
D85XS	18" x 24"	Solid Plastic (S)	18"	2	11.5	48.8	\$467

Model Builder

Model	•	1st Option Glide	•	2nd Option Frame Color	•	3rd Option Shell Color	•	4th Option Top Color
		None (X) \$0		Chrome (5) \$0		See page 101		See pages 99 + 101
D85A3	•	X	•	5	•	9H	•	3E

Model Example: D85A3.X.5.9H.3E

artcobell



Application & Specification Rules

- > 1 1/8" core standard

 > Ordered and sold as a COMPLETE table (top & legs)

 > Field installation of legs required
- > Standard with casters includes 2-locking and 2 non-locking dual wheel black casters

 > Two handle operation required to unlatch and pivot top
- > Depth of unit (except foot) when flipped up/storage position is 8-1/4"

 > Grommets available as a separately specified and field installed item. See page 87

Model	Description	Size	Leg Type Height	Units Per Ctn	Cubes Each Ctn	Lbs Each Ctn	List Price Each Laminates	List Price Each Premium Markerboard
-------	-------------	------	-------------------	---------------	----------------	--------------	---------------------------	-------------------------------------

Rectangle

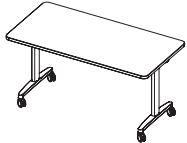

DTN5RC24F	Laminate Flat Edge (F)	24"d x 54"w	Nesting, 25" Fixed	1	6.4	71.9	\$856	\$959
DTN5RC25F	Laminate Flat Edge (F)	24"d x 60"w	Nesting, 25" Fixed	1	6.9	78.9	\$912	\$1,037
DTN5RC26F	Laminate Flat Edge (F)	24"d x 72"w	Nesting, 25" Fixed	1	8.0	89.7	\$949	\$1,091
DTN5RC34F	Laminate Flat Edge (F)	30"d x 54"w	Nesting, 25" Fixed	1	6.4	84.7	\$879	\$994
DTN5RC35F	Laminate Flat Edge (F)	30"d x 60"w	Nesting, 25" Fixed	1	6.9	92.6	\$932	\$1,066
DTN5RC36F	Laminate Flat Edge (F)	30"d x 72"w	Nesting, 25" Fixed	1	8.0	110.6	\$971	\$1,121

Expanse

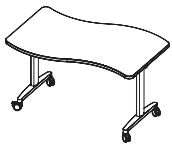

DTN5EX34F	Laminate Flat Edge (F)	30"d x 54"w	Nesting, 25" Fixed	1	6.4	89.0	\$996	\$1,157
-----------	--------------------------	-------------	--------------------	---	-----	------	-------	---------

Chevron

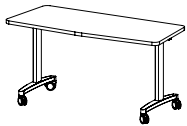

DTN5CV25	Laminate Flat Edge (F)	24"d x 60"w	Nesting, 25" Fixed	1	6.9	85.0	\$996	\$1,157
----------	--------------------------	-------------	--------------------	---	-----	------	-------	---------

Model Builder

Model	1st Option Frame Color	2nd Option Top Laminate	3rd Option Edge Color
	Titanium (4) Black (7)	See page 65	See page 65
DTN5RC24F	4	7M	4

Model Example: DTN5RC24F.4.7M.4

Half-Round (Fixed Leg | Non-Nesting)



DTF5HR48F	Laminate Flat Edge (F)	32"d x 48"w	25" Fixed	1	6.2	69.0	\$776	\$901
DTF5HR60F	Laminate Flat Edge (F)	30"d x 60"w	25" Fixed	1	6.9	73.0	\$805	\$941

Model Builder

Model	1st Option Glide	2nd Option Frame Color	3rd Option Top Laminate	4th Option Edge Color
	Caster (H) \$0	Titanium (4) Black (7) \$0	See page 65	See page 65
DTF5HR60F	H	4	7M	4

Model Example: DTF5HR60F.H.4.7M.4



Application & Specification Rules

- > 1 1/8" core standard
- > Standard with casters includes 2-locking and 2 non-locking dual wheel black casters
- > Depth of unit (except foot) when flipped up/storage position is 8-1/4"
- > Ordered and sold as a COMPLETE table (top & legs)
- > Two handle operation required to unlatch and pivot top
- > Grommets available as a separately specified and field installed item. See page 87
- > Field installation of legs required

Model	Description	Size	Leg Type Height	Units Per Ctn	Cubes Each Ctn	Lbs Each Ctn	List Price Each Laminates	List Price Each Premium Markerboard
-------	-------------	------	-------------------	---------------	----------------	--------------	---------------------------	-------------------------------------

Rectangle

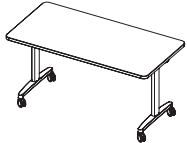

DTN7RC24F	Laminate Flat Edge (F)	24"d x 54"w	Nesting, 27" Fixed	1	6.4	71.9	\$856	\$959
DTN7RC25F	Laminate Flat Edge (F)	24"d x 60"w	Nesting, 27" Fixed	1	6.9	78.9	\$912	\$1,037
DTN7RC26F	Laminate Flat Edge (F)	24"d x 72"w	Nesting, 27" Fixed	1	8.0	89.7	\$949	\$1,091
DTN7RC34F	Laminate Flat Edge (F)	30"d x 54"w	Nesting, 27" Fixed	1	6.4	84.7	\$879	\$994
DTN7RC35F	Laminate Flat Edge (F)	30"d x 60"w	Nesting, 27" Fixed	1	6.9	92.6	\$932	\$1,066
DTN7RC36F	Laminate Flat Edge (F)	30"d x 72"w	Nesting, 27" Fixed	1	8.0	110.6	\$971	\$1,121

Expanse

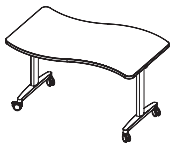

DTN7EX34F	Laminate Flat Edge (F)	30"d x 54"w	Nesting, 27" Fixed	1	6.4	89.0	\$996	\$1,157
-----------	--------------------------	-------------	--------------------	---	-----	------	-------	---------

Chevron

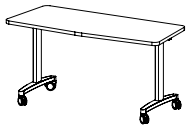

DTN7CV25F	Laminate Flat Edge (F)	24"d x 60"w	Nesting, 27" Fixed	1	6.9	85.0	\$996	\$1,157
-----------	--------------------------	-------------	--------------------	---	-----	------	-------	---------

Model Builder

Model	1st Option Frame Color	2nd Option Top Laminate	3rd Option Edge Color
	Titanium (4) Black (7)	See page 65	See page 65
DTN7CV25F	4	7M	4

Model Example: DTN7CV25.4.7M.4

Half-Round (Fixed Leg | Non-Nesting)



DTF7HR48F	Laminate Flat Edge (F)	32"d x 48"w	27" Fixed	1	6.2	69.0	\$776	\$901
DTF7HR60F	Laminate Flat Edge (F)	30"d x 60"w	27" Fixed	1	6.9	73.0	\$805	\$941

Model Builder

Model	1st Option Glide	2nd Option Frame Color	3rd Option Top Laminate	4th Option Edge Color
	Caster (H) \$0	Titanium (4) Black (7) \$0	See page 65	See page 65
DTF7HR48F	H	4	7M	4

Model Example: DTF7HR48F.H.4.7M.4

The warranty information below is effective on all Artcobell products for orders manufactured after January 1, 2017. For warranty information concerning orders placed prior to January 1, 2017, please refer to the warranty information contained in the published price list of the corresponding year. For additional information relating to warranty, please contact your Customer Service Representative.

Effective July 1, 2020

Artcobell warrants to the original purchaser that its products are free from defects in material and workmanship under normal classroom or commercial use for as long as the life of the product, except as set forth below.

During the warranty period, Artcobell will replace, or at its option, repair locally, repair at its factory, or return the purchase price of any Artcobell brand product manufactured after January 1, 2016 that, upon inspection by Artcobell, is determined to be defective in material or workmanship.

This warranty is subject to the following provisions:

Some natural variations occurring in polypropylene material or other natural materials are inherent to their character and are not considered defects. Artcobell does not warrant the colorfastness or matching of colors, grains, or textures of these materials. Customer's Own Material (COM) selected by and used at the request of an original purchaser is not warranted.

Our products are intended for interior use — exterior use of them will void the warranty.

The materials and components listed below are covered from the date of sale according to the following:

- Seating controls, glides, pneumatic cylinders, casters, chroming and polymer-based components and foam – 3 years
- User-adjustable worksurface mechanisms, tablet arm mechanisms, lounge products, occasional tables, seating upholstery fabrics and vinyls and other covering materials – 3 years

Soft seating products manufactured by artcobell are warranted to be free of defects in material and workmanship under normal use for the lifetime of the product. Product must be properly cared for, maintained and in use by its original owner. Under the warranty, the obligation of artcobell is limited to the repair or replacement of such furniture. Damage in transit or by negligence, abuse, abnormal usage, misuse, accidents or alterations nullifies the warranty.

As Buyer's sole remedy under this warranty, artcobell, at its option, will repair or replace damaged parts at no charge to the original owner of record provided the replacement or return has previously been authorized by artcobell under

terms of this warranty. Normal aging and wear of fabrics, filling materials, and finishes are excepted from this warranty. It is expressly agreed that this remedy of repair, replacement or credit, at artcobell's option, is Buyer's exclusive remedy under this warranty. In no event shall Seller be liable for consequential damages.

This warranty does not apply to:

- Normal wear and tear
- Damage from environmental factors
- Damage from sharp objects (e.g., writing utensils, heeled shoes, scissors, jewelry, and keys)
- Damage from accident, alteration, misuse, or improper installation or maintenance
- Modifications or attachments to the product not approved by Artcobell
- Products used for rental purposes
- Damage caused by the carrier in-transit, which is handled under separate terms
- Third-party products – Artcobell, to the extent possible, will pass through to the original purchaser (and process claims under) any warranty provided by third-party products supplied to Artcobell.
- All warranty claims are to be made in writing by the original purchaser. The original purchaser may be required to produce the invoice or other evidence to establish that a claim is within the warranty period.

Damage to flooring (dimpling, indentation or similar) is not covered. Warranty as to the suitability of flooring used with school furniture glides and caster rests solely with the flooring manufacturer.

To the extent allowed by law, Artcobell makes no other warranty, either express or implied, including any warranty or merchantability or fitness for a particular purpose. Artcobell is not liable for any indirect consequential or incidental damages. This warranty contains the original purchaser's exclusive remedy.

Your Artcobell Dealer is our resource in supporting your warranty requests. To obtain service under this warranty, please contact your Artcobell Dealer.