

SECTION THREE: PART A – VENDOR CONTRACT AND GENERAL TERMS AND CONDITIONS

VENDOR CONTRACT AND SIGNATURE FORM

*This Vendor Contract and Signature Form (“Contract”) is made as of May 1, 2023, by and between _____
RWC Group (“Vendor”) and Region 10 Education Service Center (“Region 10 ESC”) for the purchase of (enter category here) (“the products and services”).*

RECITALS

WHEREAS, both parties agree and understand that the following pages will constitute the contract between the successful vendor(s) and Region 10 ESC, having its principal place of business at **Education Service Center, Region 10, 400 E Spring Valley Rd, Richardson, TX 75081**

WHEREAS, Vendor agrees to include, in writing, any required exceptions or deviations from these terms, conditions, and specifications; and it is further understood that if agreed to by Region 10 ESC, said exceptions or deviations will be incorporated into the final contract “Vendor Contract.”

WHEREAS, this contract consists of the provisions set forth below, including provisions of all attachments referenced herein. In the event of a conflict between the provisions set forth below and those contained in any attachment, the provisions set forth below shall control.

WHEREAS, the Vendor Contract will provide that any state, county, special district, local government, school district, private K-12 school, technical or vocational school, higher education institution (including community colleges, colleges and universities, both public and private), other government agencies or non-profit organization may purchase products and services at prices indicated in the Vendor Contract upon registering and becoming a Member with Region 10 ESC; and it being further understood that Region 10 ESC shall act as the Lead Public Agency with respect to all such purchase agreements.

WHEREAS, Equalis Group has the administrative and legal capacity to administer purchases on behalf of Region 10 ESC under the Vendor Contract with participating public agencies and entities, as permitted by applicable law.

1. ARTICLE 1 – GENERAL TERMS AND CONDITIONS

- 1.1 Equalis Group shall be afforded all of the rights, privileges and indemnifications afforded to Region 10 ESC under the Vendor Contract, and such rights, privileges and indemnifications shall accrue and apply with equal effect to Equalis Group, including, without limitation, Vendor’s obligation to provide insurance and other indemnifications to Lead Public Agency.
- 1.2 Awarded vendor shall perform all duties, responsibilities and obligations, set forth in this agreement, and required under the Vendor Contract.
- 1.3 Equalis Group shall perform its duties, responsibilities and obligations as administrator of purchases, set forth in this agreement, and required under the Vendor Contract.

- 1.4 **Customer Support:** The vendor shall provide timely and accurate technical advice and sales support to Region 10 ESC staff, Equalis Group staff and participating agencies. The vendor shall respond to such requests within one (1) working day after receipt of the request.

2. ARTICLE 2 – ANTICIPATED TERM OF AGREEMENT

- 2.1 **Term:** The term of the Contract shall commence upon award and shall remain in effect for a period of three (3) years, unless terminated, canceled or extended as otherwise provided herein. The Contractor agrees that Region 10 ESC shall have the right, at its sole option, to renew the Contract for two (2) additional one-year periods or portions thereof. In the event that Region 10 ESC exercises such rights, all terms, conditions and provisions of the original Contract shall remain the same and apply during the renewal period with the possible exception of price and minor scope additions and/or deletions.
- 2.2 **Automatic Renewal:** Renewal will take place automatically for one (1) year unless Region 10 ESC gives written notice to the awarded supplier at least ninety (90) days prior to the expiration.

3. ARTICLE 3 – REPRESENTATIONS AND COVENANTS

- 3.1 **Scope:** This contract is based on the need to provide the economic benefits of volume purchasing and reduction in administrative costs through cooperative purchasing to schools and other Members.
- 3.2 **Compliance:** Cooperative Purchasing Agreements between Equalis Group and its Members have been established under state procurement law.
- 3.3 **Respondent's promise:** Respondent agrees all prices, terms, warranties, and benefits granted by Respondent to Members through this contract are comparable to or better than the equivalent terms offered by Respondent to any present customer meeting the same qualifications or requirements.

4. ARTICLE 4 – FORMATION OF CONTRACT

- 4.1 **Respondent contract documents:** Region 10 ESC will review proposed Respondent contract documents. Vendor's contract document shall not become part of Region 10 ESC's contract with vendor unless and until an authorized representative of Region 10 ESC reviews and approves it.
- 4.2 **Form of contract:** The form of contract for this solicitation shall be the Request for Proposal, the awarded proposal(s) to the lowest responsible Respondent(s), and properly issued and reviewed purchase orders referencing the requirements of the Request for Proposal. If a firm submitting a proposal requires Region 10 ESC and/or Member to sign an additional agreement, a copy of the proposed agreement must be included with the proposal.
- 4.3 **Entire Agreement (Parol evidence):** The contract, as specified above, represents the final written expression of agreement. All agreements are contained herein and no other agreements or representations that materially alter it are acceptable.
- 4.4 **Assignment of Contract:** No assignment of contract may be made without the prior written approval of Region 10 ESC. Purchase orders and payment can only be made to awarded vendor unless otherwise approved by Region 10 ESC. Awarded vendor is required to notify Region 10 ESC when any material change in operations is made that may adversely affect Members (i.e. awarded vendor bankruptcy, change of ownership, merger, etc.).
- 4.5 **Contract Alterations:** No alterations to the terms of this contract shall be valid or binding unless authorized and signed with a "wet signature" by a Region 10 ESC staff member.
- 4.6 **Order of precedence:** In the event of a conflict in the provisions of the contract as accepted by Region 10 ESC, the following order of precedence shall prevail:

- General terms and conditions
- Specifications and scope of work
- Attachments and exhibits
- Documents referenced or included in the solicitation

4.7 **Supplemental Agreements:** The entity participating in the Region 10 ESC contract and awarded vendor may enter into a separate supplemental agreement to further define the level of service requirements over and above the minimum defined in this contract i.e. invoice requirements, ordering requirements, specialized delivery, etc. Any supplemental agreement developed as a result of this contract is exclusively between the participating entity and awarded vendor. Neither Region 10 ESC, Equalis Group, its agents, Members and employees shall be made party to any claim for breach of such agreement.

5. ARTICLE 5 – TERMINATION OF CONTRACT

5.1 **Cancellation for non-performance or contractor deficiency:** Region 10 ESC may terminate any contract if Members have not used the contract, or if purchase volume is determined to be low volume in any 12-month period. Region 10 ESC reserves the right to cancel the whole or any part of this contract due to failure by contractor to carry out any obligation, term or condition of the contract. Region 10 ESC may issue a written deficiency notice to contractor for acting or failing to act in any of the following:

- i. Providing material that does not meet the specifications of the contract;
- ii. Providing work and/or material that was not awarded under the contract;
- iii. Failing to adequately perform the services set forth in the scope of work and specifications;
- iv. Failing to complete required work or furnish required materials within a reasonable amount of time;
- v. Failing to make progress in performance of the contract and/or giving Region 10 ESC reason to believe that contractor will not or cannot perform the requirements of the contract; and/or
- vi. Performing work or providing services under the contract prior to receiving a Region 10 ESC reviewed purchase order for such work.

Upon receipt of a written deficiency notice, contractor shall have ten (10) days to provide a satisfactory response to Region 10 ESC. Failure to adequately address all issues of concern may result in contract cancellation. Upon cancellation under this paragraph, all goods, materials, work, documents, data and reports prepared by contractor under the contract shall become the property of the Member on demand.

5.2 **Termination for cause:** If, for any reason, the Vendor fails to fulfill its obligation in a timely manner, or if the vendor violates any of the covenants, agreements, or stipulations of this contract, Region 10 ESC reserves the right to terminate the contract immediately and pursue all other applicable remedies afforded by law. Such termination shall be effective by delivery of notice, to the vendor, specifying the effective date of termination. In such event, all documents, data, studies, surveys, drawings, maps, models and reports prepared by vendor for this solicitation may become the property of the participating agency or entity. If such event does occur then vendor will be entitled to receive just and equitable compensation for the satisfactory work completed on such documents.

5.3 **Delivery/Service failures:** Failure to deliver goods or services within the time specified or within a reasonable time period as interpreted by the purchasing agent, or failure to make replacements or

corrections of rejected articles/services when so requested shall constitute grounds for the contract to be terminated. In the event that the participating agency or entity must purchase in an open market, contractor agrees to reimburse the participating agency or entity, within a reasonable time period, for all expenses incurred.

- 5.4 **Force Majeure**: If by reason of Force Majeure, either party hereto shall be rendered unable wholly or in part to carry out its obligations under this Agreement then such party shall give notice and full particulars of Force Majeure in writing to the other party within a reasonable time after occurrence of the event or cause relied upon, and the obligation of the party giving such notice, so far as it is affected by such Force Majeure, shall be suspended during the continuance of the inability then claimed, except as hereinafter provided, but for no longer period, and such party shall endeavor to remove or overcome such inability with all reasonable dispatch.

The term Force Majeure as employed herein, shall mean acts of God, strikes, lockouts, or other industrial disturbances, act of public enemy, orders of any kind of government of the United States or the State of Texas or any civil or military authority; insurrections; riots; epidemics; landslides; lighting; earthquake; fires; hurricanes; storms; floods; washouts; droughts; arrests; restraint of government and people; civil disturbances; explosions, breakage or accidents to machinery, pipelines or canals, or other causes not reasonably within the control of the party claiming such inability. It is understood and agreed that the settlement of strikes and lockouts shall be entirely within the discretion of the party having the difficulty, and that the above requirement that any Force Majeure shall be remedied with all reasonable dispatch shall not require the settlement of strikes and lockouts by acceding to the demands of the opposing party or parties when such settlement is unfavorable in the judgment of the party having the difficulty

- 5.5 **Standard Cancellation**: Either party may cancel this contract in whole or in part by providing written notice. The cancellation will take effect 90 business days after the other party receives the notice of cancellation. After the 90th business day all work will cease following completion of final purchase order. Region 10 ESC reserves the right to request additional items not already on contract at any time.

6. ARTICLE 6 – LICENSES

- 6.1 **Duty to keep current license**: Vendor shall maintain in current status all federal, state and local licenses, bonds and permits required for the operation of the business conducted by vendor. Vendor shall remain fully informed of and in compliance with all ordinances and regulations pertaining to the lawful provision of services under the contract. Region 10 ESC reserves the right to stop work and/or cancel the contract of any vendor whose license(s) expire, lapse, are suspended or terminated.
- 6.2 **Suspension or Debarment**: Respondent shall provide a letter in the proposal notifying Region 10 ESC of any debarment, suspension or other lawful action taken against them by any federal, state, or local government within the last five (5) years that precludes Respondent or its employees from participating in any public procurement activity. The letter shall state the duration of the suspension or action taken, the relevant circumstances and the name of the agency imposing the suspension. Failure to supply or disclose this information may be grounds for cancellation of contract.
- 6.3 **Survival Clause**: All applicable software license agreements, warranties or service agreements that were entered into between Vendor and Customer/participating Member under the terms and conditions of the Contract shall survive the expiration or termination of the Contract. All Purchase Orders issued and accepted by Order Fulfiller shall survive expiration or termination of the Contract.

7. ARTICLE 7 – DELIVERY PROVISIONS

- 7.1 **Delivery:** Vendor shall deliver said materials purchased on this contract to the participating Member issuing a Purchase Order. Conforming product shall be shipped within 7 days of receipt of Purchase Order. If delivery is not or cannot be made within the time specified by the Purchase Order the vendor must receive authorization from the purchasing agency for the delayed delivery. At this point the participating entity may cancel the order if estimated shipping time is not acceptable.
- 7.2 **Inspection & Acceptance:** If defective or incorrect material is delivered, purchasing agency may make the determination to return the material to the vendor at no cost to the purchasing agency. The vendor agrees to pay all shipping costs for the return shipment. Vendor shall be responsible for arranging the return of the defective or incorrect material.
- 7.3 **Responsibility for supplies tendered:** Vendor shall be responsible for the materials or supplies covered by this contract until they are delivered to the designated delivery point.
- 7.4 **Shipping Instructions:** Unless otherwise specified, each case, crate, barrel, package, etc, delivered under this contract must be plainly labeled, securely tagged, stating Vendor’s name, purchase order number, quantity contained therein, and delivery address as indicated in the order. Deliveries must be made within the hours of 8:00 am – 4:00 pm. Deliveries at any other time (including Saturdays, Sundays and holidays) will not be accepted unless arrangements have been made in advance with the receiver at the delivery point. Vendor understands that it is their responsibility to ensure compliance with the delivery instructions outlined in this agreement.
- 7.5 **Additional charges:** Unless bought on F.O.B. “shipping point” and Vendor prepays transportation, no delivery charges shall be added to invoices except when express delivery is authorized and substituted on orders for the method specified in the contract. In such cases, the difference between freight or mail and express charges may be added to the invoice.
- 7.6 **Buyer’s delays:** Region 10 ESC will not be responsible for any late fees due the prime contractor by the participating Member. The prime contractor will negotiate with the participating agency for the recovery of damages related to expenses incurred by the vendor for a delay for which the Member is responsible, which is unreasonable, and which was not within the contemplation of the parties to the contract between the two parties.

8. ARTICLE 8 – BILLING AND REPORTING

- 8.1 **Payments:** The participating entity using the contract will make payments directly to the awarded vendor. Payment shall be made after satisfactory performance, in accordance with all provisions thereof, and upon receipt of a properly completed invoice.
- 8.2 **Tax Exempt Status:** Since this is a national contract, knowing the tax laws in each state is the sole responsibility of the Vendor.

9. ARTICLE 9 – PRICING

- 9.1 **Market competitive guarantee:** Vendor agrees to provide market competitive pricing, based on the value offered upon award, to Region 10 ESC and its participating public agencies throughout the duration of the contract.
- 9.2 **Price increase:** Should it become necessary or proper during the term of this contract to make any change in design or any alterations that will increase expense, Region 10 ESC must be notified immediately. Price increases must be approved by Lead Agency and no payment for additional materials or services, beyond the amount stipulated in the contract, shall be paid without prior approval. All price increases must be supported by manufacture documentation, or a formal cost justification letter.

Vendor must honor previous prices for thirty (30) days after approval and written notification from Region 10 ESC if requested.

It is Vendor's responsibility to keep all pricing up to date and on file with Region 10 ESC. All price changes must be provided to Region 10 ESC, using the same format as was accepted in the original contract.

- 9.3 **Additional Charges:** All deliveries shall be freight prepaid, F.O.B. destination and shall be included in all pricing offered unless otherwise clearly stated in writing.
- 9.4 **Price reduction and adjustment:** Price reduction may be offered at any time during contract and shall become effective upon notice of acceptance from Region 10 ESC. Special, time-limited reductions are permissible under the following conditions: 1) reduction is available to all Members equally; 2) reduction is for a specific time period, normally not less than thirty (30) days; 3) original price is not exceeded after the time-limit; and 4) Region 10 ESC has approved the new prices prior to any offer of the prices to a Member. Vendor shall offer Region 10 ESC any published price reduction during the contract period.
- 9.5 **Prevailing Wage:** It shall be the responsibility of the Vendor to comply, when applicable, with the prevailing wage legislation in effect in the jurisdiction of the purchaser (Region 10 ESC or its Participating Members). It shall further be the responsibility of the Vendor to monitor the prevailing wage rates as established by the appropriate Department of Labor for any increase in rates during the term of this contract and adjust wage rates accordingly.
- 9.6 **Administrative Fees:** The Vendor agrees to pay administrative fees to Equalis Group based on the terms set in the Equalis Group Administration Agreement. All pricing submitted to Region 10 shall include the administrative fee to be remitted to Equalis Group by the awarded vendor.
- 9.7 **Price Calculation:** Cost plus a percentage as a primary mechanism to calculate pricing is not allowed. Pricing may either be in the form of line item pricing, defined as a specific individual price on a product or service, or a percentage discount from a verifiable catalog or price list. Other discounts or incentives may be offered.

10. ARTICLE 10 – PRICING AUDIT

- 10.1 **Audit rights:** Vendor shall, at Vendor's sole expense, maintain appropriate due diligence of all purchases made by Region 10 ESC and any participating entity that accesses this Agreement. Equalis Group and Region 10 ESC each reserve the right to audit the accounting for a period of three (3) years from the time such purchases are made. This audit right shall survive termination of this Agreement for a period of one (1) year from the effective date of termination. In the State of New Jersey, this audit right shall survive termination of this Agreement for a period of five (5) years from the date of final payment. Such records shall be made available to the New Jersey Office of the State Comptroller upon request. Region 10 ESC shall have the authority to conduct random audits of Vendor's pricing that is offered to eligible entities at Region 10 ESC's sole cost and expense. Notwithstanding the foregoing, in the event that Region 10 ESC is made aware of any pricing being offered to eligible agencies that is materially inconsistent with the pricing under this agreement, Region 10 ESC shall have the ability to conduct an extensive audit of Vendor's pricing at Vendor's sole cost and expense. Region 10 ESC may conduct the audit internally or may engage a third-party auditing firm. In the event of an audit, the requested materials shall be provided in the format and at the location designated by Region 10 ESC or Equalis Group.

11. ARTICLE 11 – PROPOSER PRODUCT LINE REQUIREMENTS

- 11.1 **Current products:** Proposals shall be for materials and equipment in current production and marketed to the general public and education/government agencies at the time the proposal is submitted.
- 11.2 **Discontinued products:** If a product or model is discontinued by the manufacturer, Vendor may substitute a new product or model if the replacement product meets or exceeds the specifications and performance of the discontinued model and if the discount is the same or greater than the discontinued model.
- 11.3 **New products/Services:** New products and/or services that meet the scope of work may be added to the contract. Pricing shall be equivalent to the percentage discount for other products. Vendor may replace or add product lines to an existing contract if the line is replacing or supplementing products on contract, is equal or superior to the original products offered, is discounted in a similar or to a greater degree, and if the products meet the requirements of the solicitation. No products and/or services may be added to avoid competitive procurement requirements. Region 10 ESC may require additions to be submitted with documentation from Participating Members demonstrating an interest in, or a potential requirement for, the new product or service. Region 10 ESC may reject any additions without cause.
- 11.4 **Options:** Optional equipment for products under contract may be added to the contract at the time they become available under the following conditions: 1) the option is priced at a discount similar to other options; 2) the option is an enhancement to the unit that improves performance or reliability.
- 11.5 **Product line:** Vendors with a published catalog may submit the entire catalog. Region 10 ESC reserves the right to select products within the catalog for award without having to award all contents. Region 10 ESC may reject any addition of equipment options without cause.
- 11.6 **Warranty conditions:** All supplies, equipment and services shall include manufacturer's minimum standard warranty and one (1) year labor warranty unless otherwise agreed to in writing.
- 11.7 **Buy American requirement:** Vendors may only use unmanufactured construction material mined or produced in the United States, as required by the Buy American Act. Where trade agreements apply, to the extent permitted by applicable law, then unmanufactured construction material mined or produced in a designated country may also be used. Vendors are required to check state specific requirements to ensure compliance with this requirement.

12. ARTICLE 12 – SITE REQUIREMENTS

- 12.1 **Cleanup:** Vendor shall clean up and remove all debris and rubbish resulting from their work as required or directed by Member. Upon completion of the work, the premises shall be left in good repair and an orderly, neat, clean and unobstructed condition conducive to the Member's business purpose.
- 12.2 **Site Preparation:** Vendor shall not begin a project for which Participating Member has not prepared the site, unless Vendor does the preparation work at no cost, or until Participating Member includes the cost of site preparation in a purchase order to the contractor. Site preparation includes, but is not limited to moving furniture, moving equipment or obstructions to the work area, installation of wiring for networks or any other necessary pre-installation requirements.
- 12.3 **Registered sex offender restrictions:** For work to be performed at schools, Vendor agrees that no employee or employee of a subcontractor who has been adjudicated to be a registered sex offender will perform work at any time when students are or are reasonably expected to be present. Vendor agrees that a violation of this condition shall be considered a material breach and may result in the cancellation of the purchase order at the Participating Member's discretion. Vendor must identify

any additional costs associated with compliance of this term. If no costs are specified, compliance with this term will be provided at no additional charge. Vendor is also responsible for ensuring that their employees or contractors who have direct contact with students are properly fingerprinted and background checked in accordance with local state law, if applicable.

- 12.4 **Safety measures:** Vendor shall take all reasonable precautions for the safety of employees on the worksite and shall erect and properly maintain all necessary safeguards for protection of workers and the public. Vendor shall post warning signs against all hazards created by its operation and work in progress. Proper precautions shall be taken pursuant to state law and standard practices to protect workers, general public and existing structures from injury or damage.
- 12.5 **Smoking/Tobacco:** Persons working under the contract shall adhere to local tobacco and smoking (including e-cigarettes/vaping) policies. Smoking will only be permitted in posted areas or off premises.
- 12.6 **Stored materials:** Upon prior written agreement between the vendor and Member, payment may be made for materials not incorporated in the work but delivered and suitably stored at the site or some other location, for installation at a later date. An inventory of the stored materials must be provided to Participating Member with the application for payment seeking compensation for stored materials. Such materials must be stored and protected in a secure location and be insured for their full value by the vendor against loss and damage. Vendor agrees to provide proof of coverage and/or addition of Participating Member as an additional insured upon Participating Member's request. Additionally, if stored offsite, the materials must also be clearly identified as property of buying Participating Member and be separated from other materials. Participating Member must be allowed reasonable opportunity to inspect and take inventory of stored materials, on or offsite, as necessary.
- Until final acceptance by the Participating Member, it shall be the Vendor's responsibility to protect all materials and equipment. Vendor warrants and guarantees that title for all work, materials and equipment shall pass to the Member upon final acceptance.
- 12.7 **Maintenance Facilities and Support:** It is preferred that each contractor should have maintenance facilities and a support system available for servicing and repair of product and/or equipment. If a third party is to be used to provide maintenance and support to the participating Member, Respondent must notify Region 10 ESC of that third party information. All technicians, applicators, installers shall be fully certified, trained and licensed to perform said duties.

13. ARTICLE 13 – MISCELLANEOUS

- 13.1 **Funding Out Clause:** Any/all contracts exceeding one (1) year shall include a standard "funding out" clause. A contract for the acquisition, including lease, of real or personal property is a commitment of the entity's current revenue only, provided the contract contains either or both of the following provisions:
- "Retains to the entity the continuing right to terminate the contract at the expiration of each budget period during the term of the contract and is conditioned on a best efforts attempt by the entity to obtain appropriate funds for payment of the contract in the subsequent fiscal year."
- 13.2 **Disclosures:** Vendor affirms that he/she has not given, offered to give, nor intends to give at any time hereafter any economic opportunity, future employment, gift, loan, gratuity, special discount, trip, favor or service to a public servant in connection with this contract.
- 13.2.1 Vendor has a continuing duty to disclose a complete description of any and all relationships that might be considered a conflict of interest in doing business with Members in Equalis Group.

- 13.2.2 Vendor affirms that, to the best of his/her knowledge, the offer was arrived at independently, and was submitted without collusion with anyone to obtain information or gain any favoritism that would in any way limit competition or give an unfair advantage over other vendors in the award of this contract.
- 13.3 **Indemnity:** Vendor shall protect, indemnify, and hold harmless both Region 10 ESC and Equalis Group and its Members, administrators, employees and agents against all claims, damages, losses and expenses arising out of or resulting from the actions of Vendor, Vendor employees or Vendor subcontractors in the preparation of the solicitation and the later execution of the contract, including any supplemental agreements with Members. Any litigation involving either Region 10 ESC or Equalis Group, its administrators and employees and agents shall be in a court of competent jurisdiction in Dallas County, Texas. Texas law shall apply to any such suit, without giving effect to its choice of laws provisions. Any litigation involving Equalis Group participating Members shall be in the jurisdiction of the participating agency.
- 13.4 **Franchise Tax:** Vendor hereby certifies that he/she is not currently delinquent in the payment of any required franchise taxes, and shall remain current on any such franchise taxes throughout the term of this contract.
- 13.5 **Marketing:** Vendor agrees to allow Region 10 ESC and Equalis Group to use their name and logo within website, marketing materials and advertisement. Any use of the Region 10 ESC or Equalis Group name and logo or any form of publicity, inclusive of press releases, regarding this contract by Vendor must have prior approval from Region 10 ESC.
- 13.6 **Insurance:** Unless otherwise modified elsewhere in this document, prior to commencing services under this contract for a participating Member, contractor shall procure, provide and maintain during the life of this agreement comprehensive public liability insurance to include course of construction insurance and automobile liability, providing limits of not less than \$1,000,000.00 per occurrence. The insurance form will be an "all risk" type of policy with standard exclusions. Coverage will include temporary structures, scaffolding, temporary office trailers, materials, and equipment. Contractor shall pay for the deductibles required by the insurance provided under this agreement.
- 13.6.1 Certificates of insurance shall be delivered to the Member prior to commencement of work. The insurance company shall be licensed to do business and write the appropriate lines of insurance in the applicable state in which work is being conducted. Vendor shall give the participating entity a minimum of ten (10) days' notice prior to any modifications or cancellation of policies. Vendor shall require all subcontractors performing any work to maintain coverage as specified.
- 13.6.2 Prior to commencing any work under this contract, any subcontractor shall also procure, provide, and maintain, at its own expense until final acceptance of the work performed, insurance coverage in a form acceptable to the prime contractor. All subcontractors shall provide worker's compensation insurance which waives all subrogation rights against the prime contractor and Member.
- 13.7 **Subcontracts/Sub Contractors:** If Vendor serves as prime contractor, it shall not enter into any subcontract subject to this solicitation without prior approval from Region 10 ESC. Any/all subcontractors shall abide by the terms and conditions of this contract and the solicitation.
- 13.7.1 No subcontract relationships shall be entered into with a party not licensed to do business in the jurisdiction in which the work will be performed. Contractor must use subcontractors openly, include such arrangements in the proposal, and certify upon request that such use

complies with the rules associated with the procurement codes and statutes in the state in which the contractor is conducting business.

13.7.2 Contractor agrees to pay subcontractors in a timely manner. Failure to pay subcontractors for work faithfully performed and properly invoiced may result in suspension or termination of this contract. Prior to participating Member's release of final retained amounts, Contractor shall produce verified statements from all subcontractors and material suppliers that those entities have been paid in full amounts due and owing to them.

13.8 **Legal Obligations:** It is the Respondent's responsibility to be aware of and comply with all local, state, and federal laws governing the sale of products/services identified in this RFP and any awarded contract and shall comply with all while fulfilling the RFP. Applicable laws and regulation must be followed even if not specifically identified herein.

13.9 **Boycott Certification:** Respondents hereby certify that during the term of any Agreement, it does not boycott Israel and will not boycott Israel. "Boycott" means refusing to deal with, terminating business activities with, or otherwise taking any action that is intended to penalize, inflict economic harm on, or limit commercial relations specifically with Israel, or with a person or entity doing business in Israel or in an Israeli-controlled territory, but does not include an action made for ordinary business purposes.

[Signatures follow on Signature Form]

PROPOSAL FORM 19: GENERAL TERMS AND CONDITIONS ACCEPTANCE FORM

Signature on the Vendor Contract Signature form certifies complete acceptance of the General Terms and Conditions in this solicitation, except as noted below (additional pages may be attached, if necessary).

Check one of the following responses to the General Terms and Conditions:

We take no exceptions/deviations to the general terms and conditions

(Note: If none are listed below, it is understood that no exceptions/deviations are taken.)

We take the following exceptions/deviations to the general terms and conditions. All exceptions/deviations must be clearly explained. Reference the corresponding general terms and conditions that you are taking exceptions/deviations to. Clearly state if you are adding additions terms and conditions to the general terms and conditions. Provide details on your exceptions/deviations below:

(Note: Unacceptable exceptions shall remove your proposal from consideration for award. Region 10 ESC shall be the sole judge on the acceptance of exceptions/deviations and the decision shall be final.)

PROPOSAL FORM 22: VENDOR CONTRACT AND SIGNATURE FORM

The undersigned hereby proposes and agrees to furnish goods and/or services in strict compliance with the terms, specifications and conditions at the prices proposed within response unless noted in writing. The undersigned further certifies that he/she is an officer of the company and has authority to negotiate and bind the company named below and has not prepared this proposal in collusion with any other Respondent and that the contents of this proposal as to prices, terms or conditions of said proposal have not been communicated by the undersigned nor by any employee or agent to any person engaged in this type of business prior to the official opening of this proposal.

VENDORS MUST SUBMIT THIS FORM COMPLETED AND SIGNED WITH THEIR RESPONSE TO BE CONSIDERED

Company name DWC Group
Address 600 N. 75th Avenue
City/State/Zip Phoenix AZ 85043
Telephone No. 602-377-4401
Fax No. _____
Email address thartman@dwcgroup.com
Printed name Thomas Hartman
Position with company General Manager
Authorized signature 

Term of contract May 1, 2023 to April 30, 2026

Unless otherwise stated, all contracts are for a period of three (3) years with an option to renew annually for an additional two (2) years if agreed to by Region 10 ESC. Vendor shall honor all administrative fees for any sales made based on the contract whether renewed or not.



Region 10 ESC Authorized Agent

4/19/23

Date

Dr. Rickey Williams

Print Name

Equalis Group Contract Number R10-1148B

**REQUEST FOR PROPOSAL #R10-1148 FOR:
SCHOOL BUSES & SHUTTLES**

February 10, 2023

Section Two:
Proposal Submission, Questionnaire and
Required Forms

Proposal Form Checklist	3
PROPOSAL FORM 1: ATTACHMENT B – PRICING	4
PROPOSAL FORM 2: QUESTIONNAIRE & EVALUATION CRITERIA	5
PROPOSAL FORM 3: CERTIFICATIONS AND LICENSES	13
PROPOSAL FORM 4: CLEAN AIR WATER ACT	14
PROPOSAL FORM 5: DEBARMENT NOTICE.....	15
PROPOSAL FORM 6: LOBBYING CERTIFICATION	16
PROPOSAL FORM 7: CONTRACTOR CERTIFICATION REQUIREMENTS.....	17
PROPOSAL FORM 8: ANTITRUST CERTIFICATION STATEMENTS.....	18
PROPOSAL FORM 9: IMPLEMENTATION OF HOUSE BILL 1295.....	19
PROPOSAL FORM 10: BOYCOTT CERTIFICATION AND TERRORIST STATE CERTIFICATION.....	20
PROPOSAL FORM 11: RESIDENT CERTIFICATION.....	21
PROPOSAL FORM 12: FEDERAL FUNDS CERIFICATION FORM.....	22
PROPOSAL FORM 13: ADDITIONAL ARIZONA CONTRACTOR REQUIREMENTS.....	28
PROPOSAL FORM 14: OWNERSHIP DISCLOSURE FORM (N.J.S. 52:25-24.2).....	30
PROPOSAL FORM 15: NON-COLLUSION AFFIDAVIT	31
PROPOSAL FORM 16: AFFIRMATIVE ACTION AFFIDAVIT (P.L. 1975, C.127).....	32
PROPOSAL FORM 17: C. 271 POLITICAL CONTRIBUTION DISCLOSURE FORM.....	35
PROPOSAL FORM 18: STOCKHOLDER DISCLOSURE CERTIFICATION.....	40
PROPOSAL FORM 19: GENERAL TERMS AND CONDITIONS ACCEPTANCE FORM.....	41
PROPOSAL FORM 20: EQUALIS GROUP ADMINISTRATION AGREEMENT	42
PROPOSAL FORM 21: OPEN RECORDS POLICY ACKNOWLEDGEMENT AND ACCEPTANCE.....	43
PROPOSAL FORM 22: VENDOR CONTRACT AND SIGNATURE FORM.....	44

Proposal Form Checklist

The following documents must be submitted with the Proposal

The below documents can be found in Section 2; Proposal Submission and Required Bid Forms and must be submitted with the proposal. Please note Proposal Form 1 is a separate attachment (attachment B).

PROPOSAL PRICING: Attachment B is provided separately in a Microsoft Excel file and is required to complete your price proposal.

PROPOSAL FORM 1: ATTACHMENT B - PRICING

QUESTIONNAIRE & EVALUATION CRITERIA:

PROPOSAL FORM 2: QUESTIONNAIRE & EVALUATION CRITERIA

OTHER REQUIRED PROPOSAL FORMS:

- PROPOSAL FORM 3: CERTIFICATIONS AND LICENSES
- PROPOSAL FORM 4: CLEAN AIR AND WATER ACT
- PROPOSAL FORM 5: DEBARMENT NOTICE
- PROPOSAL FORM 6: LOBBYING CERTIFICATION
- PROPOSAL FORM 7: CONTRACTOR CERTIFICATION REQUIREMENTS
- PROPOSAL FORM 8: ANTITRUST CERTIFICATION STATEMENTS
- PROPOSAL FROM 9: IMPLEMENTATION OF HOUSE BILL 1295
- PROPOSAL FROM 10: BOYCOTT CERTIFICATION AND TERRORIST STATE CERTIFICATION
- PROPOSAL FORM 11: RESIDENT CERTIFICATION
- PROPOSAL FORM 12: FEDERAL FUNDS CERIFICATION FORM
- PROPOSAL FORM 13: ADDITIONAL ARIZONA CONTRACTOR REQUIREMENTS
- PROPOSAL FORM 14: OWNERSHIP DISCLOSURE FORM (N.J.S. 52:25-24.2)
- PROPOSAL FORM 15: NON-COLLUSION AFFIDAVIT
- PROPOSAL FORM 16: AFFIRMATIVE ACTION AFFIDAVIT (P.L. 1975, C.127)
- PROPOSAL FORM 17: C. 271 POLITICAL CONTRIBUTION DISCLOSURE FORM
- PROPOSAL FORM 18: STOCKHOLDER DISCLOSURE CERTIFICATION
- PROPOSAL FORM 19: GENERAL TERMS AND CONDITIONS ACCEPTANCE FORM
- PROPOSAL FORM 20: EQUALIS GROUP ADMINISTRATION AGREEMENT
- PROPOSAL FORM 21: OPEN RECORDS POLICY ACKNOWLEDGEMENT AND ACCEPTANCE
- PROPOSAL FORM 22: VENDOR CONTRACT AND SIGNATURE FORM

(The rest of this page is intentionally left blank)

PROPOSAL FORM 1: ATTACHMENT B – PRICING

Pricing should be entered in the attachment B Excel form provided in this RFP packet. Please reference Section 1, Part B, Instructions to Proposers, for more information on how to complete pricing.

(The rest of this page is intentionally left blank)

PROPOSAL FORM 2: QUESTIONNAIRE & EVALUATION CRITERIA

Instructions:

Respondents should incorporate their questionnaire responses directly into the green cells below. Failure to provide responses in this format may result in the proposal being deemed as non-responsive at the sole discretion of Region 10.

Respondents may incorporate additional documents as part of their response which may be utilized by Region 10 as part of the evaluation. Additional documents must be consolidated as part of this Section 2 at the end of your response.

Region 10 has associated the evaluation criteria with the question that most closely aligns with that respective evaluation criteria. Region 10 reserves the right at its sole discretion to base its evaluation and specific evaluation criteria on any part of the respondent's proposal.

Evaluation Criteria		Question	Answer
Basic Information			
Required information for notification of RFP results	What is your company's official registered name?	RWC GROUP	
	What is the mailing address of your company's headquarters?	600 NORTH 75 TH AVENUE PHOENIX, AZ 85043	
	Who is the main contact for any questions and notifications concerning this RFP response, including notification of award? Provide name, title, email address, and phone number.	THOMAS HARTMAN, GENERAL MANAGER, THARTMAN@RWCGROUP.COM, 602-377-4401	
Products/Pricing (30 Points)			
Coverage of products and services	No answer is required. Region 10 will utilize your overall response and the products/services provided in Attachment B to make this determination		
Ability of offered products and services to meet the needs requested in the scope	No answer is required. Region 10 will utilize your overall response and the products/services provided in Attachment B to make this determination		
Pricing for all available products and services, including warranties if applicable	Does the respondent agree to offer all future product and services at prices that are proportionate to contract pricing offered herein?	YES	
	Does pricing submitted include the required administrative fee?	YES	

	<p>Do you offer any other promotions or incentives for customers? If yes, please describe.</p> <p>Were all products/lines/services and pricing being made available under this contract provided in the attachment B and/or Appendix B, pricing sections?</p> <p>Outline your pricing strategy provided in Attachment B. If utilizing a list price, please indicate where agencies can find the list and your methodology for determining that list price.</p> <p>Define your invoicing process and methods of payments you will accept. Please include the overall process for agencies to make payments</p> <p>No answer is required. Region 10 will utilize your overall response and the products/services provided in Attachment B to make this determination</p>	<p>YES. DEPENDING ON THE TIME OF THE YEAR WE DO OFFER PROMOTIONS AND DISCOUNTS OFFERED BY OUR MANUFACTURERS</p> <p>YES</p> <p>PURCHASING A SCHOOL BUS WILL BE A NOT TO EXCEED PRICE. CUSTOMER WILL NEED TO CONTACT RWC AND IN ENGAGE ON WHAT SPECIFIC SPECIFICATIONS WILL BE REQUIRED TO PROVIDE THEM A PROPOSAL. IN ALL CASES, ALL PROPOSALS WILL NEVER EXCEED THE NOT TO EXCEED PRICE ON OUR COLLINS, IC BUS AND GREENPOWER MOTRO COMPANY PRODUCTS. FOR PARTS WE WILL OFFER A LIST PRICE LESS A 18% DISCOUNT. FOR SERVICE REPAIRS OR MOBILE SERVICE, WE WILL OVER A STANDARD LABOR RATE</p> <p>ALL CUSTOMERS WILL RECEIVE A NET 30 ACCOUNT TO PAY FOR A BUS, PARTS OR SERVICE TRANSACTION. NO CREDIT CARDS ACCEPTED.</p>
<p>Ability of Customers to verify that they received contract pricing</p>		
<p>Payment methods</p>		
<p>Other factors relevant to this section as submitted by the Respondent</p>		
<p>Performance Capability (25 Points)</p>		
<p>Ability to meet the defined scope</p>	<p>Please provide a high-level overview of the products and services being offered and how they address the scope being requested herein.</p> <p>Provide the variations of bus and shuttle types along with associated fuel types offered.</p>	<p>RWC GROUP HAS 15 LOCATIONS ACROSS 5 STATES IN AZ,NV,CA,WA AND AK. WE PROVIDE CLEAN DIESEL,GASOLINE AND ELECTRIC SCHOOL BUS AND TRUCK PRODUCTS. WE WORK WITH SCHOOL DISTRICTS,CHARTER SCHOOLS, PRIVATE SCHOOLS, CHURCHES, UNIVERSITIES AND GOVERNMENT AGENCIES. ALL SERVICE LOCATIONS ARE OUR EMPLOYEES AND WE PROVIDE PARTS AND SERVICE SUPPORT. WE HAVE AN EXTENSIVE MOBILE SERVICE DEPARTMENTOALLING 42 TRUCKS TO SERVICE CUSTOMERS AND THEIR FACILITIES. THE CUSTOMER SERVICE EXPEERIENCE WE PROVIDE ALONG WITH OUR EXSTENSIVE PRODUCT OFFERING FULLY COVERS THE SCOPE AND GOALS FOR REGION 10. WE BELIEVE WE WOULD BE A GREAT PARTNER.</p> <p>RWC GROUP REPRESENTS 3 SCHOOL BUS MAUFACTURERS. IC BUS, COLLINS BUS AND GREENPOWER MOTOR COMPANY. OUR PRODUCT OOFERINGS COVER CLEAN DIESEL, GASOLINE AND ELECTRIC. GREENPOWER MOTOR COMPANY, OFFERS 2 PRODUCTS. TYPE D ELECTRIC TRANSIT SCHOOL BUS AND A TYPE A ELECTRIC SCHOOL BUS. THE TYPE D OFFERS THE HIGHEST STUDENT CAPACITY IN THE INDUSTRY AT UP TO 90 PASSENGERS. THE HISTORIC STRUGGLE WITH FINDING DRIVERS HAS FORCED TRANSPORTATION DEPARTMENTS TO CONSOLIDATE ROUTES. HIGH CAPCTY SCHOOL BUSES WILL BE A PREMIUM TO HELP COMBAT THE DRIVER SHORTAGE. LION BUS CLAIMS TO HAVE A TYPE D EV BUS BUT HAS YET TO DELIVIER ONE BUS IN NORTH AMERICA IN THE LAST 2 YEARS DESPITE HAVING PURCHASE ORDERS. THERE CAPACITY IS ONLY 72. BLUE BIRD ONLY OFFERS A 78 PASSENGER AT ONLY 90 MILES RANGE AND NO LUGGAGE COMPARTMENTS. THE GREENPOWER BUS IS ALSO THE ONLY TYPE D BUS TO OFFER PASS THRU LUGGAGE. THIS MAKES THIS EV BUS AVAILALE FOR SMALL SPORTS ROUTES IN ADDITION TO REGUALR ROUTE BUSES. THE GREENPOWER BUS IS BUILT FROM THE GROUND UP TO BE A EV BUS. IC BUS OFFERS ALL VARIATIONS OF SCHOOL BUSES WITH CIMMINS CLEAN DIESEL AND ELECTRIC SCHOOL BUSES. IC IS THE ONLY SCHOOL BUS OEM TO OFFER A 3 BATTERY EV BUS WITH 225 PLUS RANGE ON ONE SINGLE CHARGE. THE REST OF THE INDUSTRY IS AT 80-130 MILE RANGE WITH A 2 BATTERY. IC BUS IS THE ONLY BUS OEM TO OFFER A SHORT WHEELBASE SPECIAL NEEDS ELECTRIC BUS. WE BELIEVE THE SPECILA NEEDS SEGMENT IS A GREAT PLACE</p>

		<p>FOR SCHOOL DISTRICTS TO START WITH ELECTRIC AS SOME STUDENTS HAVE ISSUES WITH NOISE AND VIBRATION. EV IS A GREAT OFFERING.</p> <p>ZONAR, GPS, ALL BRANDS OF CAMERA SYSTEMS AND VEHICLE MONITORING. WE OFFER A MONTHLY SUBSCRIPTION TO MONITOR YOUR FLEET AND PROVIDE ALERTS AND DIAGNOSTIC TROUBLE TREES WHEN YOU VEHICLE HAS AN ISSUE.</p> <p>THE STATES OF ARIZONA, NEVADA, CALIFORNIA, WASHINGTON STATE AND ALASKA</p> <p>6 LOCATIONS IN ARIZONA, 1 IN NEVADA (CLARK COUNTY SCHOOL DISTRICT), 2 IN CALIFORNIA, 2 IN ALASKA AND 4 LOCATIONS IN WASHINGTON STATE. 42 MOBILE SERVICE TRUCKS ACROSS ALL STATES TO PERFORM WORK AT THE CUSTOMER LOCATION</p> <p>WE HAVE A DEDICATED SCHOOL BUS PARTS TEAM OF 9 INDIVIDUALS WITH 15 PLUS YEARS EACH OF BUS EXPERIENCE BOTH SCHOOL BUS AND COMMERCIAL. CUSTOMER EMAIL THEM AT BUSPARTS@RWCGROUP.COM OR CALL AT 1-855-428-7727</p> <p>RWC GROUP ALONG WITH ITS BUS OEM'S ARE FULLY AWARE AND EXPERIENCED IN FEDERAL AND STATE MINIMUM STANDARDS FOR ALL OF OUR TERRITORIES. ALL OUR SCHOOL BUSES ARE BUILT TO COMPLY.</p>
<p>Describe any vehicle technology products or equipment you can provide.</p>	<p>States Covered - Respondent must indicate any and all states or geographies where products and services are being offered. If your services are limited to a certain area, please be specific on the area your services are provided.</p> <p>List the number and location of offices, or service centers for all states being proposed in solicitation</p> <p>Outline any other capabilities not already addressed.</p>	
<p>Ability to meet defined safety specifications</p>	<p>Outline how respondent addresses the specifications and safety standards defined by state, local, and/or federal requirements.</p>	
<p>Response to emergency orders and maintenance repair/requests</p>	<p>Describe the type of emergency orders or requests your organization typically receives and how you respond to those requests</p>	<p>ALL OF OUR LOCATIONS HAVE A DESIGNATED SERVICE ADVISOR THAT OUR CUSTOMERS KNOW TO CALL TO SETUP AN APPOINTMENT TO ADDRESS A CONCERN OR REPAIR. WE UTILIZE A SOFTWARE PROGRAM THAT COMMUNICATES WITH THE CUSTOMER DURING THE COURSE OF THE REPAIR. YOUR BUS IS CHECKED IN, BUS HAS BEEN ASSIGNED TO A TECH, HERE IS THE ISSUE AND AN ESTIMATE TO REPAIR, BUS COMPLETE AND INLINE FOR A ROAD TEST, BUS READY FOR PICKUP. WE ALSO UTILIZE OUR 24-HOUR MOBILE SERVICE TRUCKS FOR EMERGENCIES.</p> <p>HOURS ARE 6AM TO 5PM IN ALL LOCATIONS. WE HAVE 15 SERVICE LOCATIONS AND 42 MOBILE SERVICE TRUCKS. RESOLVING ISSUES IS PRETTY BROAD STATEMENT. WE DO WHATEVER IT TAKES WITHIN REASON TO GET THE CURSRTOEMR TAKEN CARE OF. THEY ARE OUR LIFELINE.</p> <p>We don't provide financial date without a NDA.</p>
<p>Customer service/problem resolution</p>	<p>Describe your company's Customer Service Department (hours of operation, how you resolve issues, number of service centers, etc.).</p>	
<p>Financial condition of vendor</p>	<p>Demonstrate your financial strength and stability with meaningful data. This could include, but is not limited to, such items as financial statements, SEC filings, credit & bond ratings, letters of credit, and detailed reference letters</p> <p>What was your annual sales volume over last three (3) years?</p>	<p>2022 Parts = 139 Million Service = 48 Million Wholegoods = 202 Million</p>

		<p>2021 Parts = 109 Million Service = 39 Million Wholegoods = 237 Million</p> <p>2020 Parts = 97 Million Service = 31 Million Wholegoods = 226 Million</p>
Contract implementation / Customer training	Describe training or support you provide to help agencies understand how to utilize the spaces and technology equipment being installed.	<p>WE HAVE A CORPORATE TRAINER WHO SUPPORTS ALL RWC GROUP LOCATIONS AND ITS CUSTOMERS FOR THE SPECIFIC TRAINING NEEDS OUR CUSTOMERS REQUEST. WE OFTEN UTILIZE THE VARIOUS VENDORS WE USE TO PROVIDE THE TRAINING FOR CUSTOMERS. A MAJORITY OF THE TIME THIS FREE TO THE CUSTOMERS. IC BUS WHICH IS ONE OEM WE REPRESENT OFFERS SOEMTHIGN CALLED IC BUS UNIVERSITY. IT'S A WEEKLONG TRAINING IN WHICH A TECHNICIAN CAN RECEIVE HIGH LEVEL TRAINING ON ENGINES, FUEL TYPES, TRANSMISSIONS, BRAKES, ELECTRICAL ETC...</p>
History of meeting product and services timeline	Outline the process for timeline for product delivery, invoicing and any other applicable capabilities not already addressed.	<p>WHEN WE ORDER A BUS THROUGH OUR MANUFACTURER WE ARE GIVEN AND BUILD DATE AND COMPLETION DATE IN WHICH WE SHARE WITH OUR CUSTOMER. ONCE THE BUS HITS OUR LOT WE WORK INTERNALLY TO HAVE THE BUS GO THROUGH OUR PRE-DELIVERY INSPECTION. THE CUSTOMER IS COMMUNICATED WITH THROUGHOUT THE PROCESS. ON THE SERVICE SIDE WE MONITOR DWELL TIME. THIS IS HOW LONG OUR BUSES TAKE TO REPAIR AND RETURN TO THE CUSTOMER FROM THE CHECK IN OF THE BUS UNTIL COMPLETION.</p>
Other factors relevant to this section as submitted by the Respondent	Describe the capacity of your company to provide management reports, i.e. consolidated billing by location, time and attendance reports, etc. for each eligible agency Provide your safety record, safety rating, EMR and worker's compensation rate where available.	<p>OUR INTERNAL TIME AND ATTENDANCE IS REPORT THROUGH ADP SOFTWARE. OUR FINANCIAL REPORTS AND DEPARTMENTAL REPORTS ARE THROUGH A SOFTWARE CALL PROCEDE. WE ARE ABLE TO PROVIDE DIRECT BILLING AND OR CONSOLIDATED BILLING.</p> <p><i>MOD rate of .94 RWC Total hours: 1,987,791 Days Aug = 8 DART: 16 Incident Rate 24 Overall: .06, 1.61, 2.41 days</i></p>
Qualification and Experience (25 Points)		
Respondent reputation in the marketplace	Provide a link to your company's website Please provide a brief history of your company, including the year it was established.	<p>www.rwcgroup.com</p> <p>RWC Group is a Family-owned commercial truck and bus dealership. We have 700 employees spread across several locations in AZ, CA, OR, WA and AK. The company sells and leases all kinds of trucks and buses to meet all your needs. We provide a wide array service including repair, maintenance, alignment, DPF cleaning, body shop and mobile service. Our extensive parts inventory includes OEM parts from a vast list of manufacturers so we're sure to have what you're looking for. RWC Group is led by Robert W (Bob) Cunningham. Bob began his career in the trucking industry in 1973 at IML Freight Lines loading trucks as he worked his way through The University of Utah. After graduation, Cunningham spent six years in sales and operations at Motor Cargo.</p> <p>In 1985, Bob joined Swift Transportation where he served as executive vice president of sales and marketing, a member of the board of directors and later President and CEO. From 1997 to 2005, Cunningham owned and operated one of the nation's most successful Freightliner truck dealerships.</p>

		<p>In 2010, Bob purchased all three International® Truck dealerships and Idealease locations in Arizona.</p> <p>2014 was a year of major growth with the addition of three locations in Southern California and the purchase of four locations in Washington and Alaska. In February 2015, we completed our northwest footprint with the addition of three more Washington stores.</p> <p>2022 was another year of growth with the addition of a Parts Store in the Deer Valley area of Phoenix, and the purchase of our 15th location in Pendleton, Oregon.</p> <p>Bob Cunningham and the entire RWC Group staff are committed to providing a superior customer service experience at every one of our locations in Arizona, Alaska, California, Oregon and Washington.</p> <p>Being a Dealer for Collins Bus we worked through Collins membership with region 10 to sell Clark county school district 15 Collins buses. Clark County is the 5th largest school district in the country.</p>
<p>Past relationship with Region 10 ESC and/or Region 10 ESC members</p> <p>Experience and qualification of key employees</p>	<p>Have you worked with Region 10 in the past? If so, what was the timeframe for that work?</p> <p>Please provide contact information and resumes for the person(s) who will be responsible for the following areas. Region 10 requests contacts to cover the following:</p> <ul style="list-style-type: none"> * Executive Support * Account Manager * Contract Manager * Marketing * Billing, reporting & Accounts Payable 	<p>Executive Support and Contract Manager Thomas Hartman, General Manager of School Bus Operations. 602-377-4401 or thartman@rwcgroup.com Will be responsible for this contract.</p> <p>30 years' experience in the bus industry Account Manager: Luke Vaughan 602-397-1466 or lvaughan@rwcgroup.com, 29 years in the bus industry Billing, reporting and AP: Vickie Priest Senior Accounting Manager vpriest@rwcgroup.com or 602-307-1095</p>
<p>Past experience working with the public sector</p>	<p>What are your overall public sector sales, excluding Federal Government, for last three (3) years?</p>	<p>2022 Parts = 139 Million Service = 48 Million Wholegoods = 202 Million</p> <p>2021 Parts = 109 Million Service = 39 Million Wholegoods = 237 Million</p> <p>2020 Parts = 97 Million Service = 31 Million Wholegoods = 226 Million</p> <p>Increased Marketing Presence and a continued focus on customer service and experience. Our product set is impressive.</p>
<p>Past litigation, bankruptcy, reorganization, state investigations of entity or current officers and directors</p>	<p>What is your strategy to increase market share in the public sector?</p> <p>Provide information regarding whether your firm, either presently or in the past, has been involved in any litigation, bankruptcy, or reorganization.</p>	<p>No Bankruptcy or Reorganization. Company is 90% owned by Robert W Cunningham and 10% owned by Rudger Hefner As a 700 plus employee company and 15 locations I'm sure we are involved in litigation from time to time but nothing that would bar us from being a strong partner.</p>

<p>Minimum of 5 public sector customer references relating to the products and services within this RFP</p>	<p>Provide a minimum of five (5) customer references for product and/or services of similar scope dating within the past 3 years. Please try to provide references for K12, Higher Education, City/County and State entities. Provide the entity; contact name & title; city & state; phone number; years serviced; description of services; and annual volume</p>	<p>Patrick Fleming, Flagstaff Unified, Transportation Director. 928-527-2302 Flagstaff, Arizona 15 plus years selling diesel, gas and propane buses along with parts and service. \$500,00 plus in annual volume Jerry Sturgill, Marana Unified School District, Fleet Manager 520-616-6386 Marana, AZ 15 plus years \$500,00 in annual volume selling buses, parts and service Tom Spellman, Lake Washington SD, Fleet Manager 425-864-0777 Redmond, WA 15 plus years and \$1 million in annual volume Heather Philp Anchorage SD, Anchorage Alaska Transportation Director. 10 plus years and \$300,00 in annual volume Jennifer Vobus 702-799-8100 ext 5003 Clark County School District Las Vegas Nevada 2 years 1 million in annual volume</p>
<p>Certifications in the Industry</p>	<p>Provide a copy of all current licenses, registrations and certifications issued by federal, state and local agencies, and any other licenses, registrations or certifications from any other governmental entity with jurisdiction, allowing Respondent to perform the covered services including, but not limited to licenses, registrations or certifications. M/WBE, HUB, DVBE, small and disadvantaged business certifications and other diverse business certifications, as well as manufacturer certifications for sales and service must be included if applicable</p>	<p>attached</p>
<p>Company profile and capabilities</p>	<p>What best describes your position in the distribution channel? (Manufacturer, Authorized Distributor, Value-Add Reseller, Other</p>	<p>Authorized Distributor/Dealer</p>
<p>Other factors relevant to this section as submitted by the Respondent</p>	<p>If your company is a privately held organization, please indicate if the company is owned or operated by anyone who has been convicted of a felony. If yes, a detailed explanation of the names and conviction is required.</p>	<p>Family owned and the answer is no</p>
<p>Provide a copy of all current licenses, registrations and certifications issued by federal, state and local agencies, and any other licenses, registrations or certifications from any other governmental entity with jurisdiction, allowing Respondent to perform the covered services. These will be provided in the space provided in Form 6. No answer is required here.</p>		
<p>MWBE Status and/or Program Capabilities (10 Points)</p>		
<p>MWBE status, subcontractor plan, and/or joint venture program</p>	<p>Please indicate whether you hold any diversity certifications, including, but not limited to MWBE, SBE, DBE, DVBE, HUB, or HUBZone</p>	<p>N/A</p>
<p>Do you currently have a diversity program in place, such as a Mentor Protégé Program or subcontractor program? If you have a diversity program, please describe it and indicate</p>	<p></p>	<p>N/A</p>

<p>Good faith efforts to involve MWBE subcontractors in response</p>	<p>whether you plan to offer your program or partnership through Equalis Group? Please attach any certifications you have as part of your response to Form 6.</p> <p>Did your company contact MWBEs or minority chambers of commerce by telephone, written correspondence, or trade associations at least one week before the due date of this RFP to provide information relevant to this opportunity and to determine whether any MWBEs were interested in subcontracting and/or joint ventures?</p>	<p>NO</p>
<p>Demonstrated ongoing MWBE program</p>	<p>Outline your subcontractor strategy and efforts your organization takes to include MWBE subcontractors in future work, including but not limited to efforts to reach out to individual MWBE businesses, minority chambers of commerce, and other minority business and trade associations.</p>	<p>N/A</p>
<p>Commitment to Service Equalis Group Members (10 Points)</p>		
<p>Marketing plan, capability, and commitment</p>	<p>Detail how your organization plans to market and promote this contract upon award, including how this contract will fit into your organization's current go-to-market strategy in the public sector.</p> <p>Detail how your organization will train your sales force and customer service representatives on this contract to ensure that they can competently and consistently present the contract to public agency customers and answer any questions they might have concerning it.</p>	<p>Communication via our marketing teams to all customers in the states will be sent on a monthly basis. We will also display our membership to Equalis at various conferences and trade shows as well as our social medial pages.</p> <p>We will hold an internal team training with our parts, service, and sales teams to discuss the contract in detail. This is an important contract for RWC, and we want to ensure that we value the contract and do all we can to make sure this is successful.</p>
<p>Ability to manage a cooperative contract</p>	<p>Acknowledge that your organization agrees to provide its company logo(s) to Region 10 ESC and Equalis Group and agrees to provide permission for reproduction of such logo in marketing communications and promotions</p> <p>Describe the capacity of your company to report monthly sales through this agreement to Equalis Group.</p> <p>Identify any contracts with other cooperative or government group purchasing organizations of which your company is currently a part of:</p>	<p>Agreed</p> <p>Our Sales coordinators will report monthly like other contracts we belong to.</p> <p>Mohave Educational Services Cooperative, OSPi and ADOIT</p>

<p>Commitment to supporting agencies to utilize the contract</p>	<p><i>If awarded a contract, how would you approach agencies in regards to this contract? Please indicate how this would work for both new customers to your organization, as well as existing.</i></p>	<p>Not all customers have a vehicle to purchase via a procurement tool. We would utilize Equalis in those situations. In other situations, we will explain the value in utilizing Equalis if there current procurement isn't working.</p>
<p>Other factors relevant to this section as submitted by the Respondent</p>	<p><i>Provide the number of sales representatives which will work on this contract and where the sales representatives are located.</i></p>	<p>9 sales representatives in Arizona, 3 in Alaska, 2 in Nevada, 2 in CA and 4 in Washington.</p>

PROPOSAL FORM 3: CERTIFICATIONS AND LICENSES

Provide a copy of all current licenses, registrations and certifications issued by federal, state and local agencies, and any other licenses, registrations or certifications from any other governmental entity with jurisdiction, allowing Respondent to perform the covered services including, but not limited to licenses, registrations or certifications. M/WBE, HUB, DVBE, small and disadvantaged business certifications and other diverse business certifications, as well as manufacturer certifications for sales and service must be included if applicable.



Arizona Department of Revenue

CERTIFICATE TO ESTABLISH RESIDENCY IN ANOTHER U.S. STATE PURSUANT TO A.R.S. § 42-5009

**ARIZONA FORM
5011**

FOR PURPOSE OF A STATUTORY DEDUCTION PROVIDED BY ARS § 42-5061, SUBSECTION (A)(14)(a)-(b), (A)(28)(a), (A)(44), OR (U)

SECTION 1 - INFORMATION TO BE SUPPLIED BY SELLER

SELLER'S NAME AND ADDRESS: 600 N 75th Ave Phoenix AZ 85043				
YEAR: 2005	MAKE: BLUE BIRD	MODEL: SCHOOL BUS / TR	VIN NO.: 1BABKCKA65F225077	90 DAY PERMIT NO.:
SALES PRICE: 1.#R		PRICE ADJUSTMENTS: 0.00	NET PRICE: 1.#R	TOTAL TAXES PAID: 0.00
DRIVER'S LICENSE NO. OF PURCHASER (or Entity Rep.):			STATE OF ISSUANCE:	EXPIRES:

IF CLAIMING THE COMMERCIAL MOTOR VEHICLE USED IN INTERSTATE COMMERCE SOLD TO NONRESIDENT EXEMPTION, THE SELLER MUST FILL OUT THE FOLLOWING INFORMATION ABOUT THE PURCHASER:
 USDOT # _____ | MC/MX/FF #(s) _____ | INTERSTATE COMMERCE: Y ___ N ___ | GVWR _____
 Note: To be eligible, vehicle must be operated in interstate commerce and have a gross vehicle weight rating (GVWR) over 10,000 pounds.

SECTION 2 - TO BE COMPLETED BY PURCHASER (OR ENTITY REPRESENTATIVE)

FULL NAME: GARCIA TRUCK AND BUS SALES	
FULL RESIDENTIAL ADDRESS (NO P.O. BOXES): 800 THORPE RD ORLANDO FL 32824	
TELEPHONE NO. OF RESIDENCE ADDRESS: (321) 200-6585	AUTO INSURANCE COMPANY: <i>Century Surety Company</i>
IF PURCHASER IS A NONRESIDENT ENTITY, COMPLETE THE FOLLOWING: ENTITY NAME:	
FULL BUSINESS ADDRESS:	
POLICY NO.: CCP1075677	FEIN: 81-2229466
TELEPHONE NO.:	

QUESTIONS TO BE ANSWERED AND INITIALED BY PURCHASER (OR ENTITY REP.):

NOTE: DO NOT answer questions 1, 2, and 3 if you are a Nonresident U.S. Military Service member (or spouse) officially stationed at an Arizona military facility, a Nonresident Student enrolled at an Arizona Educational Institution paying out-of-state tuition fees, or a nonresident working in Arizona but who lives outside of Arizona within 25 miles of the border. **(PROVIDE COPY OF MILITARY ORDERS OR CURRENT STUDENT I.D. CARD)**

	True	False	Initial
1. I am physically present in Arizona for at least seven (7) months of the year.....	<input type="checkbox"/>	<input type="checkbox"/>	_____
2. I am engaged in a trade, profession or occupation in Arizona in other than seasonal agricultural work or temporary seasonal work.....	<input type="checkbox"/>	<input type="checkbox"/>	_____
3. I am employed in the State of Arizona.....	<input type="checkbox"/>	<input type="checkbox"/>	_____
4. I attend an Arizona educational institution and pay resident status tuition rates.....	<input type="checkbox"/>	<input checked="" type="checkbox"/>	JA
5. I am an individual or entity that maintains a main office, branch office or warehouse facilities in this state and that bases and operates motor vehicles in this state.....	<input type="checkbox"/>	<input checked="" type="checkbox"/>	JA
6. I am an individual or entity that operates motor vehicles in transportation services within Arizona, for other than seasonal agricultural work.....	<input type="checkbox"/>	<input checked="" type="checkbox"/>	JA
7. I am purchasing this vehicle for transfer to a resident of Arizona.....	<input type="checkbox"/>	<input checked="" type="checkbox"/>	JA
8. I have a valid driver's license issued by the State of Arizona.....	<input type="checkbox"/>	<input checked="" type="checkbox"/>	JA
9. I am registered to vote in the State of Arizona.....	<input type="checkbox"/>	<input checked="" type="checkbox"/>	JA
10. I file Resident status income tax returns, or business tax returns in the State of Arizona.....	<input type="checkbox"/>	<input checked="" type="checkbox"/>	JA
11. The insurance policy listed above (other than a temporary binder) is issued under the laws of Arizona.....	<input type="checkbox"/>	<input checked="" type="checkbox"/>	JA

NOTE: FOR SECTION 2, AN ARIZONA ADDRESS OR ANY TRUE ANSWER RENDERS THE PURCHASER INELIGIBLE.

AFFIDAVIT OF NONRESIDENCY

AFFIRMATIONS OF PURCHASER:

I will register this vehicle in the state of Florida prior to the expiration of the 90 Day Nonresident Registration Permit, and will not use this vehicle in Arizona after this date for other than purely temporary or transitory purposes.

I will personally be liable for an amount equal to the state, county and city taxes that would have applied to a non-exempt sale, plus penalties and interest computed from the date of sale, if this vehicle is registered in Arizona within 365 days of the date of sale.

I will personally be liable for an amount equal to the state, county and city taxes that would have applied to a non-exempt sale, plus penalties and interest computed from the date of sale, if I have provided false information on this certificate.

I understand that in Arizona, it is a Class 5 Felony to "knowingly prepare, present or aid, procure or advise in preparing or presenting any return, affidavit, claim or other document which is fraudulent or is false as to any material matter, whether or not the falsity or fraud is with the knowledge or consent of the taxpayer authorized or required to present the return, affidavit, claim or document." [See A.R.S. § 42-1127(B)(2)]

I understand that I will be subject to criminal penalties if I have either omitted required information or provided false information on this certificate. [See A.R.S. § 42-1127(B)(4)]

If claiming the commercial motor vehicle sold to a nonresident exemption under A.R.S. § 42-5061(A)(14)(b), I verify that I am authorized to use the vehicle in interstate commerce as defined in 49 U.S.C. § 13501.

I have verified that my driver's license information provided on Page 1 is correct.

I hereby certify that the information I have provided on this Certificate is true, accurate and complete. Further, if I am the representative of a nonresident entity, I certify that I am authorized to execute this Certificate on behalf of the nonresident entity named above.

Signed by:

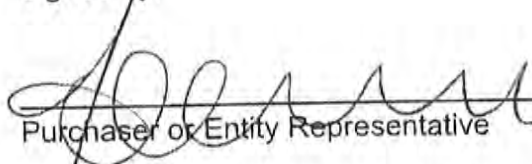
Purchaser or Entity Representative

1-6-2023
Date

Alaska Department of Commerce, Community, and Economic Development

Division of Corporations, Business, and Professional Licensing
PO Box 110806, Juneau, AK 99811-0806

This is to certify that

RWC INTERNATIONAL. LTD

600 N 75TH AVE, PHOENIX, AZ 85043

owned by

RWC INTERNATIONAL. LTD

is licensed by the department to conduct business for the period

October 8, 2021 to December 31, 2023
for the following line(s) of business:

42 - Trade

This license shall not be taken as permission to do business in the state without having complied with the other requirements of the laws of the State or of the United States.

This license must be posted in a conspicuous place at the business location.
It is not transferable or assignable.

Julie Anderson
Commissioner



ARIZONA DEPARTMENT OF REVENUE
ATTN: Customer Care and Outreach
PO BOX 29032
Phoenix, AZ 85038-9032



ARIZONA DEPARTMENT OF REVENUE
TRANSACTION PRIVILEGE TAX LICENSE
NOT TRANSFERABLE

The licensee listed below is licensed to conduct business upon the condition that taxes are paid to Arizona Department of Revenue as required under provisions of A.R.S. Title 42, Chapter 5, Article 1.

2023

ISSUED TO: RWC INTERNATIONAL LTD
600 N 75TH AVE
PHOENIX AZ 85043

ALL communications and reports MUST REFER to this LICENSE NO.

LICENSE: 20541212
START DATE: 05/01/2010
ISSUED: 02/08/2023
EXPIRES: 12/31/2023

LOCATION: CODE 002
RWC INTERNATIONAL LTD
600 N 75TH AVE
PHOENIX, AZ 85043
2300064993162



BUSINESS CODE

017 - RETAIL
029 - USE TAX
017 - RETAIL
029 - USE TAX
030 - USE TAX FROM INVENTORY
162 - Retail Sales (Single Item Portion over \$11,631)

REGION

MAR - MARICOPA
MAR - MARICOPA
PX - PHOENIX
PX - PHOENIX
PX - PHOENIX
PX - PHOENIX

JURISDICTION

COUNTY
COUNTY
CITY
CITY
CITY
CITY

This License is issued to the business named above for the address shown. Licenses, by law, cannot be transferred from one person to another, nor can they be transferred from one location to another. Arizona law requires licensees to notify the Department of Revenue if there is a change in business name, trade name, location, mailing address, or ownership. In addition, when the business ceases to operate or the business location changes and a new license is issued, this license must be returned to the Arizona Department of Revenue. According to R15-5-2201, license must be displayed in a conspicuous place.

000120308F0000P6891160400012

ARIZONA DEPARTMENT OF REVENUE
ATTN: Customer Care and Outreach
PO BOX 29032
Phoenix, AZ 85038-9032



ARIZONA DEPARTMENT OF REVENUE
TRANSACTION PRIVILEGE TAX LICENSE
NOT TRANSFERABLE

The licensee listed below is licensed to conduct business upon the condition that taxes are paid to Arizona Department of Revenue as required under provisions of A.R.S. Title 42, Chapter 5, Article 1.

2023

ISSUED TO: RWC INTERNATIONAL LTD
600 N 75TH AVE
PHOENIX AZ 85043

ALL communications and reports MUST REFER to this LICENSE NO.

→ LICENSE: 20541212
START DATE: 05/01/2010
ISSUED: 02/08/2023
EXPIRES: 12/31/2023

LOCATION: CODE 003
RWC INTERNATIONAL LTD
3220 E IRVINGTON RD
TUCSON, AZ 85714
2300064993162



BUSINESS CODE

017 - RETAIL
029 - USE TAX
030 - USE TAX FROM INVENTORY

REGION

PMA - PIMA
PMA - PIMA
PMA - PIMA

JURISDICTION

COUNTY
COUNTY
COUNTY

This License is issued to the business named above for the address shown. Licenses, by law, cannot be transferred from one person to another, nor can they be transferred from one location to another. Arizona law requires licensees to notify the Department of Revenue if there is a change in business name, trade name, location, mailing address, or ownership. In addition, when the business ceases to operate or the business location changes and a new license is issued, this license must be returned to the Arizona Department of Revenue. According to R15-5-2201, license must be displayed in a conspicuous place.

000120408ND000P6891160400012

ARIZONA DEPARTMENT OF REVENUE
ATTN: Customer Care and Outreach
PO BOX 29032
Phoenix, AZ 85038-9032



ARIZONA DEPARTMENT OF REVENUE
TRANSACTION PRIVILEGE TAX LICENSE
NOT TRANSFERABLE

The licensee listed below is licensed to conduct business upon the condition that taxes are paid to Arizona Department of Revenue as required under provisions of A.R.S. Title 42, Chapter 5, Article 1.

2023

ISSUED TO: RWC INTERNATIONAL LTD
600 N 75TH AVE
PHOENIX AZ 85043

ALL communications and
reports MUST REFER to
this LICENSE NO.

LICENSE: 20541212
START DATE: 05/01/2010
ISSUED: 02/08/2023
EXPIRES: 12/31/2023

LOCATION: CODE 004
RWC INTERNATIONAL
3901 E HUNTINGTON DR
FLAGSTAFF, AZ 86004
2300064993162

BUSINESS CODE

017 - RETAIL
029 - USE TAX
017 - RETAIL
029 - USE TAX

REGION

COC - COCONINO
COC - COCONINO
FS - FLAGSTAFF
FS - FLAGSTAFF

JURISDICTION

COUNTY
COUNTY
CITY
CITY

This License is issued to the business named above for the address shown. Licenses, by law, cannot be transferred from one person to another, nor can they be transferred from one location to another. Arizona law requires licensees to notify the Department of Revenue if there is a change in business name, trade name, location, mailing address, or ownership. In addition, when the business ceases to operate or the business location changes and a new license is issued, this license must be returned to the Arizona Department of Revenue. According to R15-5-2201, license must be displayed in a conspicuous place.

00012060870000P6891160400012

ARIZONA DEPARTMENT OF REVENUE
ATTN: Customer Care and Outreach
PO BOX 29032
Phoenix, AZ 85038-9032



ARIZONA DEPARTMENT OF REVENUE
TRANSACTION PRIVILEGE TAX LICENSE
NOT TRANSFERABLE

The licensee listed below is licensed to conduct business upon the condition that taxes are paid to Arizona Department of Revenue as required under provisions of A.R.S. Title 42, Chapter 5, Article 1.

2023

ISSUED TO: RWC INTERNATIONAL LTD
600 N 75TH AVE
PHOENIX AZ 85043

ALL communications and reports MUST REFER to this LICENSE NO.

▶ LICENSE: 20541212
START DATE: 05/01/2010
ISSUED: 02/08/2023
EXPIRES: 12/31/2023

LOCATION: CODE 006
RWC INTERNATIONAL LTD
7125 E. GILA RIDGE ROAD
YUMA, AZ 85365
2300064993162



BUSINESS CODE

017 - RETAIL
029 - USE TAX
030 - USE TAX FROM INVENTORY
017 - RETAIL

REGION

YMA - YUMA
YMA - YUMA
YMA - YUMA
YM - YUMA

JURISDICTION

COUNTY
COUNTY
COUNTY
CITY

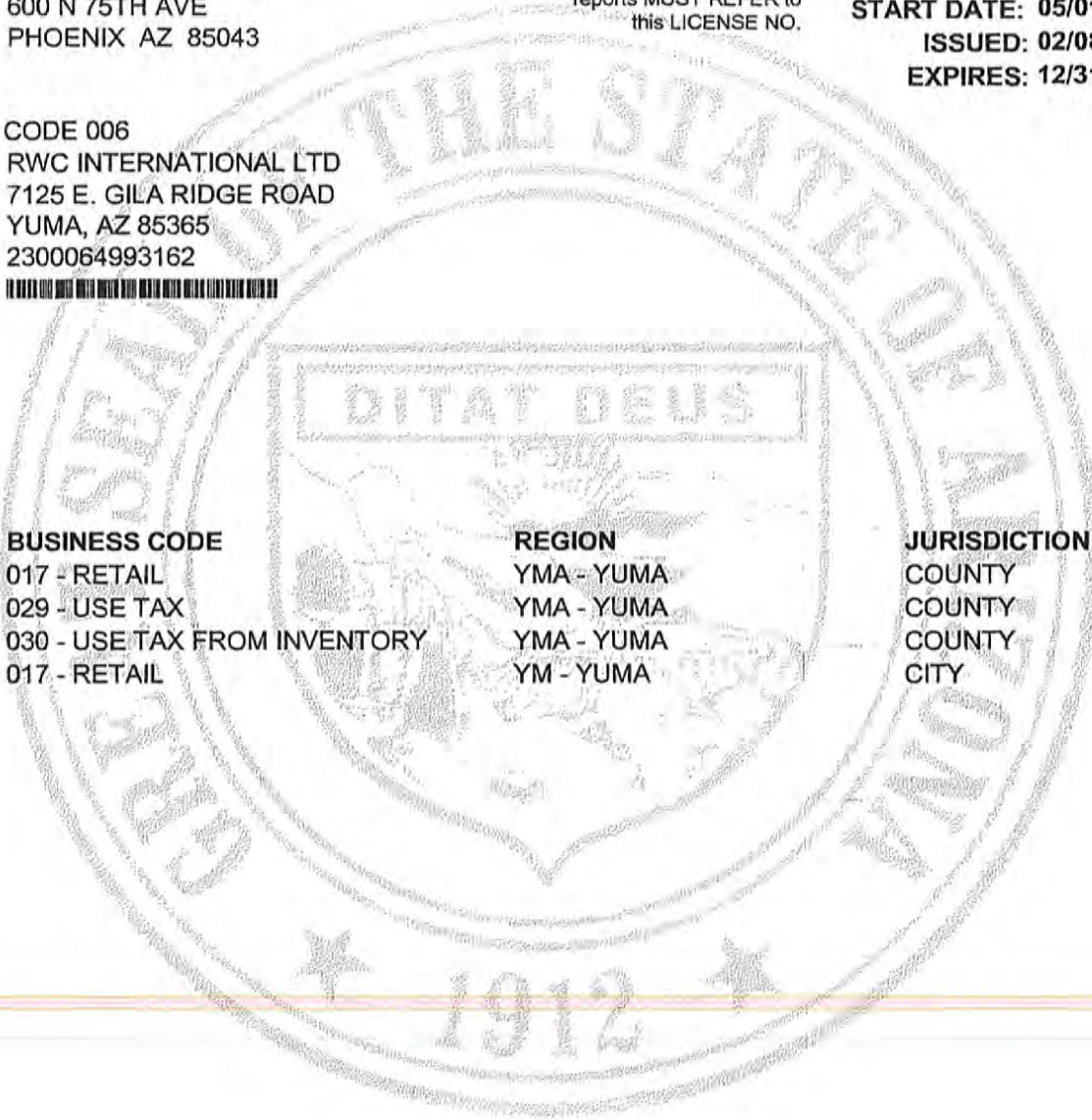

000120708B0000P6891160400012

This License is issued to the business named above for the address shown. Licenses, by law, cannot be transferred from one person to another, nor can they be transferred from one location to another. Arizona law requires licensees to notify the Department of Revenue if there is a change in business name, trade name, location, mailing address, or ownership. In addition, when the business ceases to operate or the business location changes and a new license is issued, this license must be returned to the Arizona Department of Revenue. According to R15-5-2201, license must be displayed in a conspicuous place.

ARIZONA DEPARTMENT OF REVENUE
ATTN: Customer Care and Outreach
PO BOX 29032
Phoenix, AZ 85038-9032



ARIZONA DEPARTMENT OF REVENUE
TRANSACTION PRIVILEGE TAX LICENSE
NOT TRANSFERABLE

The licensee listed below is licensed to conduct business upon the condition that taxes are paid to Arizona Department of Revenue as required under provisions of A.R.S. Title 42, Chapter 5, Article 1.

2023

ISSUED TO: RWC INTERNATIONAL LTD
600 N 75TH AVE
PHOENIX AZ 85043

ALL communications and reports MUST REFER to this LICENSE NO.

LICENSE: 20541212
START DATE: 05/01/2010
ISSUED: 02/08/2023
EXPIRES: 12/31/2023

LOCATION: CODE 007
DEER VALLEY
21430 N 2ND AVE
PHOENIX, AZ 85027-2964
2300064993162

BUSINESS CODE

017 - RETAIL
029 - USE TAX
030 - USE TAX FROM INVENTORY
017 - RETAIL
029 - USE TAX
030 - USE TAX FROM INVENTORY

REGION

MAR - MARICOPA
MAR - MARICOPA
MAR - MARICOPA
PX - PHOENIX
PX - PHOENIX
PX - PHOENIX

JURISDICTION

COUNTY
COUNTY
COUNTY
CITY
CITY
CITY

This License is issued to the business named above for the address shown. Licenses, by law, cannot be transferred from one person to another, nor can they be transferred from one location to another. Arizona law requires licensees to notify the Department of Revenue if there is a change in business name, trade name, location, mailing address, or ownership. In addition, when the business ceases to operate or the business location changes and a new license is issued, this license must be returned to the Arizona Department of Revenue. According to R15-5-2201, license must be displayed in a conspicuous place.

000120508J0000P6691160400012



BUSINESS LICENSE

STATE OF
WASHINGTON
Profit Corporation

RWC INTERNATIONAL, LTD.
RWC GROUP
13123 48TH AVE S
TUKWILA WA 98168-3305

UNEMPLOYMENT INSURANCE - ACTIVE
TAX REGISTRATION - ACTIVE

INDUSTRIAL INSURANCE - ACTIVE
MOTOR VEHICLE DEALER #00661 - ACTIVE

TEMPORARILY CLOSED UNDERGROUND STORAGE TANKS (1): D98 - ON HOLD Temporary Closure

CITY ENDORSEMENTS:

TUKWILA GENERAL BUSINESS - ACTIVE
BURIEN GENERAL BUSINESS - NON-RESIDENT #11952 - ACTIVE

LICENSING RESTRICTIONS:

Not licensed to hire minors without a Minor Work Permit.

REGISTERED TRADE NAMES:

RWC GROUP

Issue Date: Dec 30, 2022

Unified Business ID #: 603436098

Business ID #: 001

Location: 0003

Expires: Jan 31, 2024

This document lists the registrations, endorsements, and licenses authorized for the business named above. By accepting this document, the licensee certifies the information on the application was complete, true, and accurate to the best of his or her knowledge, and that business will be conducted in compliance with all applicable Washington state, county, and city regulations.

Director, Department of Revenue

IBI: 603436098 001 0003

STATE OF WASHINGTON

Expires: Jan 31, 2024

WC INTERNATIONAL, LTD.
WC GROUP
3123 48TH AVE S
JKWILA WA 98168-3305

FOLD HERE

UNEMPLOYMENT INSURANCE -
ACTIVE
INDUSTRIAL INSURANCE - ACTIVE
TAX REGISTRATION - ACTIVE
MOTOR VEHICLE DEALER #00661 -
ACTIVE
UNDERGROUND STORAGE
TANKTUKWILA GENERAL BUSINESS
- ACTIVE
BURIEN GENERAL BUSINESS -
NON-RESIDENT #11952 - ACTIVE

FOLD HERE



BUSINESS LICENSE

STATE OF
WASHINGTON
Profit Corporation

Issue Date: Dec 30, 2022
Unified Business ID #: 603436098
Business ID #: 001
Location: 0001
Expires: Jan 31, 2024

RWC INTERNATIONAL, LTD.
RWC GROUP
2312 MILWAUKEE WAY
TACOMA WA 98421-2710

UNEMPLOYMENT INSURANCE - ACTIVE
TAX REGISTRATION - ACTIVE

INDUSTRIAL INSURANCE - ACTIVE
MOTOR VEHICLE DEALER SUBAGENCY #00661 -
ACTIVE

LICENSING RESTRICTIONS:

Not licensed to hire minors without a Minor Work Permit.

REGISTERED TRADE NAMES:

RWC GROUP

This document lists the registrations, endorsements, and licenses authorized for the business named above. By accepting this document, the licensee certifies the information on the application was complete, true, and accurate to the best of his or her knowledge, and that business will be conducted in compliance with all applicable Washington state, county, and city regulations.

Director, Department of Revenue

BI: 603436098 001 0001

STATE OF WASHINGTON

Expires: Jan 31, 2024

WC INTERNATIONAL, LTD.
WC GROUP
312 MILWAUKEE WAY
TACOMA WA 98421-2710

FOLD HERE

UNEMPLOYMENT INSURANCE -
ACTIVE
INDUSTRIAL INSURANCE - ACTIVE
TAX REGISTRATION - ACTIVE
MOTOR VEHICLE DEALER
SUBAGENCY #00661 - ACTIVE

FOLD HERE



BUSINESS LICENSE

STATE OF
WASHINGTON
Profit Corporation

Issue Date: Dec 30, 2022
Unified Business ID #: 603436098
Business ID #: 001
Location: 0002
Expires: Jan 31, 2024

RWC INTERNATIONAL, LTD.
RWC GROUP
1509 S 22ND ST
YAKIMA WA 98901-9518

UNEMPLOYMENT INSURANCE - ACTIVE
TAX REGISTRATION - ACTIVE

INDUSTRIAL INSURANCE - ACTIVE
MOTOR VEHICLE DEALER SUBAGENCY #00661 -
ACTIVE

CITY ENDORSEMENTS:

YAKIMA GENERAL BUSINESS #BLS200062 - ACTIVE

LICENSING RESTRICTIONS:

Not licensed to hire minors without a Minor Work Permit.

REGISTERED TRADE NAMES:

RWC GROUP

This document lists the registrations, endorsements, and licenses authorized for the business named above. By accepting this document, the licensee certifies the information on the application was complete, true, and accurate to the best of his or her knowledge, and that business will be conducted in compliance with all applicable Washington state, county, and city regulations.

Director, Department of Revenue

STATE OF WASHINGTON

BI: 603436098 001 0002

WC INTERNATIONAL, LTD.
WC GROUP
309 S 22ND ST
YAKIMA WA 98901-9518

FOLO HERE

UNEMPLOYMENT INSURANCE -
ACTIVE
INDUSTRIAL INSURANCE - ACTIVE
TAX REGISTRATION - ACTIVE
MOTOR VEHICLE DEALER
SUBAGENCY #00661 - ACTIVE
YAKIMA GENERAL BUSINESS
#BLS200062 - ACTIVE

FOLO HERE

Expires: Jan 31, 2024



BUSINESS LICENSE

STATE OF
WASHINGTON
Profit Corporation

Issue Date: Dec 30, 2022
Unified Business ID #: 603436098
Business ID #: 001
Location: 0004
Expires: Jan 31, 2024

RWC INTERNATIONAL, LTD.
RWC GROUP
824 N THIERMAN RD
SPOKANE VALLEY WA 99212-1124

UNEMPLOYMENT INSURANCE - ACTIVE
TAX REGISTRATION - ACTIVE

INDUSTRIAL INSURANCE - ACTIVE
MOTOR VEHICLE DEALER SUBAGENCY #00661 -
ACTIVE

CITY ENDORSEMENTS:

SPOKANE VALLEY GENERAL BUSINESS - ACTIVE
SPOKANE GENERAL BUSINESS - NON-RESIDENT - ACTIVE

LICENSING RESTRICTIONS:

Not licensed to hire minors without a Minor Work Permit.

REGISTERED TRADE NAMES:

RWC GROUP

This document lists the registrations, endorsements, and licenses authorized for the business named above. By accepting this document, the licensee certifies the information on the application was complete, true, and accurate to the best of his or her knowledge, and that business will be conducted in compliance with all applicable Washington state, county, and city regulations.

Director, Department of Revenue

STATE OF WASHINGTON

BI: 603436098 001 0004

Expires: Jan 31, 2024

RWC INTERNATIONAL, LTD.
RWC GROUP
824 N THIERMAN RD
SPOKANE VALLEY WA 99212-1124

FOLD HERE

UNEMPLOYMENT INSURANCE -
ACTIVE
INDUSTRIAL INSURANCE - ACTIVE
TAX REGISTRATION - ACTIVE
MOTOR VEHICLE DEALER
SUBAGENCY #00661 - ACTIVE
SPOKANE VALLEY GENERAL
BUSINESS - ACTIVE
SPOKANE GENERAL BUSINESS -
NON-RESIDENT - ACTIVE

FOLD HERE

City of Huntington Park
 City Hall
 6550 Miles Ave.
 Huntington Park CA 90255-1519
 (323) 584-6232

Business License /Permit NO 23-00023872
DISPLAY IN A PROMINENT PLACE.

This License issued Subject to the conditions Listed on the Reverse side hereof		Amount Paid 4,051.00	State License Number
LICENSE NOT TRANSFERABLE		BOFE NO	Business License Number 23-00023872
Type of Business	TRUCK SALES DEALERSHIP	Account Number 0018919	
Business Location		License Stamp / Tag	
Business Name	RWC GROUP	License Valid From	
Owner Name	FRED M. BOERNER MOTOR CO. 3620 FLORENCE AVE HUNTINGTON PARK CA 90255	License Expires	
Mailing Address		Date Issued October 31, 2023	
		September 19, 2022	

By _____

[Handwritten Signature]

PROPOSAL FORM 4: CLEAN AIR WATER ACT

I, the Vendor, am in compliance with all applicable standards, orders or regulations issued pursuant to the Clean Air Act of 1970, as Amended (42 U.S. C. 1857 (h), Section 508 of the Clean Water Act, as amended (33 U.S.C. 1368), Executive Order 117389 and Environmental Protection Agency Regulation, 40 CFR Part 15 as required under OMB Circular A-102, Attachment O, Paragraph 14 (1) regarding reporting violations to the grantor agency and to the United States Environment Protection Agency Assistant Administrator for the Enforcement.

Potential Vendor: RWC Group

Title of Authorized Representative: General Manager

Mailing Address: 600 N. 75th Ave Phoenix AZ 85043

Signature: 

PROPOSAL FORM 5: DEBARMENT NOTICE

I, the Vendor, certify that my company has not been debarred, suspended or otherwise ineligible for participation in Federal Assistance programs under Executive Order 12549, "Debarment and Suspension", as described in the Federal Register and Rules and Regulations.

Potential Vendor: DWC Group

Title of Authorized Representative: General Manager

Mailing Address: 600 N. 75th Avenue Phoenix AZ 85043

Signature: 

PROPOSAL FORM 6: LOBBYING CERTIFICATION

Submission of this certification is a prerequisite for making or entering into this transaction and is imposed by Section 1352, Title 31, U.S. Code. This certification is a material representation of fact upon which reliance was placed when this transaction was made or entered into. Any person who fails to file the required certification shall be subject to civil penalty of not less than \$10,000 and not more than \$100,000 for each such failure.

The undersigned certifies, to the best of his/her knowledge and belief, that:

1. No Federal appropriated funds have been paid or will be paid on behalf of the undersigned, to any person for influencing or attempting to influence an officer or employee of any agency, a Member of Congress, an officer or employee of Congress, or an employee of a Member of Congress in connection with the awarding of a Federal contract, the making of a Federal grant, the making of a Federal loan, the entering into a cooperative agreement, and the extension, continuation, renewal, amendment, or modification of a Federal contract, grant, loan, or cooperative agreement.
2. If any funds other than Federal appropriated funds have been or will be paid to any person for influencing or attempting to influence an officer or employee of any agency, a Member of Congress, an officer or employee of Congress, or an employee of a Member of Congress in connection with this Federal contract or cooperative agreement, the undersigned shall complete and submit Standard Form LLL, "Disclosure of Lobbying Activities," in accordance with its instructions.
3. The undersigned shall require that the language of this certification be included in the award documents for all covered sub-awards exceeding \$100,000 in Federal funds at all appropriate tiers and that all sub-recipients shall certify and disclose accordingly.



Signature of Respondent

3-10-23

Date

PROPOSAL FORM 7: CONTRACTOR CERTIFICATION REQUIREMENTS

Contractor's Employment Eligibility

By entering the contract, Contractor warrants compliance with the Federal Immigration and Nationality Act (FINA), and all other federal and state immigration laws and regulations. The Contractor further warrants that it is in compliance with the various state statutes of the states it will operate this contract in.

Participating Government Entities including School Districts may request verification of compliance from any Contractor or subcontractor performing work under this Contract. These Entities reserve the right to confirm compliance in accordance with applicable laws.

Should the Participating Entities suspect or find that the Contractor or any of its subcontractors are not in compliance, they may pursue any and all remedies allowed by law, including, but not limited to: suspension of work, termination of the Contract for default, and suspension and/or debarment of the Contractor. All costs necessary to verify compliance are the responsibility of the Contractor.

The Respondent complies and maintains compliance with the appropriate statutes which requires compliance with federal immigration laws by State employers, State contractors and State subcontractors in accordance with the E-Verify Employee Eligibility Verification Program.

Contractor shall comply with governing board policy of the Region 10 ESC Participating entities in which work is being performed.

Fingerprint & Criminal Background Checks

If required to provide services on school district property at least five (5) times during a month, contractor shall submit a full set of fingerprints to the school district if requested of each person or employee who may provide such service. Alternately, the school district may fingerprint those persons or employees. An exception to this requirement may be made as authorized in Governing Board policy. The district shall conduct a fingerprint check in accordance with the appropriate state and federal laws of all contractors, subcontractors or vendors and their employees for which fingerprints are submitted to the district. Contractor, subcontractors, vendors and their employees shall not provide services on school district properties until authorized by the District.

The Respondent shall comply with fingerprinting requirements in accordance with appropriate statutes in the state in which the work is being performed unless otherwise exempted.

Contractor shall comply with governing board policy in the school district or Participating Entity in which work is being performed.



Signature of Respondent



Date

PROPOSAL FORM 8: ANTITRUST CERTIFICATION STATEMENTS
(Tex. Government Code § 2155.005)

I affirm under penalty of perjury of the laws of the State of Texas that:

- (1) I am duly authorized to execute this contract on my own behalf or on behalf of the company, corporation, firm, partnership or individual (Company) listed below;
- (2) In connection with this proposal, neither I nor any representative of the Company has violated any provision of the Texas Free Enterprise and Antitrust Act, Tex. Bus. & Comm. Code Chapter 15;
- (3) In connection with this proposal, neither I nor any representative of the Company has violated any federal antitrust law; and
- (4) Neither I nor any representative of the Company has directly or indirectly communicated any of the contents of this proposal to a competitor of the Company or any other company, corporation, firm, partnership or individual engaged in the same line of business as the Company.

VENDOR RWC Group

ADDRESS 600 N. 75th Avenue
Phoenix, AZ 85043

PHONE 602-377-4401

FAX _____

RESPONDANT

[Signature]
Signature

Thang Hartman
Printed Name

General Manager
Position with Company

AUTHORIZING OFFICIAL

[Signature]
Signature

Thang Hartman
Printed Name

General Manager
Position with Company

PROPOSAL FORM 9: IMPLEMENTATION OF HOUSE BILL 1295

Certificate of Interested Parties (Form 1295):

In 2015, the Texas Legislature adopted House Bill 1295, which added section 2252.908 of the Government Code. The law states that a governmental entity or state agency may not enter into certain contracts with a business entity unless the business entity submits a disclosure of interested parties to the governmental entity or state agency at the time the business entity submits the signed contract to the governmental entity or state agency. The law applies only to a contract of a governmental entity or state agency that either (1) requires an action or vote by the governing body of the entity or agency before the contract may be signed or (2) has a value of at least \$1 million. The disclosure requirement applies to a contract entered into on or after January 1, 2016.

The Texas Ethics Commission was required to adopt rules necessary to implement that law, prescribe the disclosure of interested parties form, and post a copy of the form on the commission's website. The commission adopted the Certificate of Interested Parties form (Form 1295) on October 5, 2015. The commission also adopted new rules (Chapter 46) on November 30, 2015, to implement the law. The commission does not have any additional authority to enforce or interpret House Bill 1295.

Filing Process:

Starting on January 1, 2016, the commission will make available on its website a new filing application that must be used to file Form 1295. A business entity must use the application to enter the required information on Form 1295 and print a copy of the completed form, which will include a certification of filing that will contain a unique certification number. An authorized agent of the business entity must sign the printed copy of the form and have the form notarized. The completed Form 1295 with the certification of filing must be filed with the governmental body or state agency with which the business entity is entering into the contract.

The governmental entity or state agency must notify the commission, using the commission's filing application, of the receipt of the filed Form 1295 with the certification of filing not later than the 30th day after the date the contract binds all parties to the contract. The commission will post the completed Form 1295 to its website within seven business days after receiving notice from the governmental entity or state agency.

Information regarding how to use the filing application will be available on this site starting on January 1, 2016. https://www.ethics.state.tx.us/whatsnew/elf_info_form1295.htm

PROPOSAL FORM 10: BOYCOTT CERTIFICATION AND TERRORIST STATE CERTIFICATION

BOYCOTT CERTIFICATION

Respondents must certify that during the term of any Agreement, it does not boycott Israel and will not boycott Israel. "Boycott" means refusing to deal with, terminating business activities with, or otherwise taking any action that is intended to penalize, inflict economic harm on, or limit commercial relations specifically with Israel, or with a person or entity doing business in Israel or in an Israeli-controlled territory, but does not include an action made for ordinary business purposes.

Does vendor agree? TH
(Initials of Authorized Representative)

TERRORIST STATE CERTIFICATION

In accordance with Texas Government Code, Chapter 2252, Subchapter F, REGION 10 ESC is prohibited from entering into a contract with a company that is identified on a list prepared and maintained by the Texas Comptroller or the State Pension Review Board under Texas Government Code Sections 806.051, 807.051, or 2252.153. By execution of any agreement, the respondent certifies to REGION 10 ESC that it is not a listed company under any of those Texas Government Code provisions. Responders must voluntarily and knowingly acknowledge and agree that any agreement shall be null and void should facts arise leading the REGION 10 ESC to believe that the respondent was a listed company at the time of this procurement.

Does vendor agree? TH
(Initials of Authorized Representative)

PROPOSAL FORM 11: RESIDENT CERTIFICATION

This Certification Section must be completed and submitted before a proposal can be awarded to your company. This information may be placed in an envelope labeled "Proprietary" and is not subject to public view. In order for a proposal to be considered, the following information must be provided. Failure to complete may result in rejection of the proposal:

As defined by Texas House Bill 602, a "nonresident Bidder" means a Bidder whose principal place of business is not in Texas, but excludes a contractor whose ultimate parent company or majority owner has its principal place of business in Texas.

Texas or Non-Texas Resident

- I certify that my company is a "resident Bidder"
- I certify that my company qualifies as a "nonresident Bidder"

If you qualify as a "nonresident Bidder," you must furnish the following information:

What is your resident state? (The state your principal place of business is located.)

RWC Group 600 N. 75th Ave Phoenix AZ 85043 Phoenix

Company Name Address City

State Zip

PROPOSAL FORM 12: FEDERAL FUNDS CERIFICATION FORM

When a participating agency seeks to procure goods and services using funds under a federal grant or contract, specific federal laws, regulations, and requirements may apply in addition to those under state law. This includes, but is not limited to, the procurement standards of the Uniform Administrative Requirements, Cost Principles and Audit Requirements for Federal Awards, 2 CFR 200 (sometimes referred to as the "Uniform Guidance" or "EDGAR" requirements). All Vendors submitting proposals must complete this Federal Funds Certification Form regarding Vendor's willingness and ability to comply with certain requirements which may be applicable to specific participating agency purchases using federal grant funds. This completed form will be made available to participating agencies for their use while considering their purchasing options when using federal grant funds. Participating agencies may also require Vendors to enter into ancillary agreements, in addition to the contract's general terms and conditions, to address the member's specific contractual needs, including contract requirements for a procurement using federal grants or contracts.

For each of the items below, Vendor should certify Vendor's agreement and ability to comply, where applicable, by having Vendor's authorized representative complete and initial the applicable lines after each section and sign the acknowledgment at the end of this form. If a vendor fails to complete any item in this form, Region 10 ESC will consider the Vendor's response to be that they are unable or unwilling to comply. A negative response to any of the items may, if applicable, impact the ability of a participating agency to purchase from the Vendor using federal funds.

1. Vendor Violation or Breach of Contract Terms:

Contracts for more than the simplified acquisition threshold currently set at \$150,000, which is the inflation adjusted amount determined by the Civilian Agency Acquisition Council and the Defense Acquisition Regulations Council (Councils) as authorized by 41 USC 1908, must address administrative, contractual, or legal remedies in instances where contractors violate or breach contract terms, and provide for such sanctions and penalties as appropriate.

Any Contract award will be subject to Region 10 ESC General Terms and Conditions, as well as any additional terms and conditions in any Purchase Order, participating agency ancillary contract, or Member Construction Contract agreed upon by Vendor and the participating agency which must be consistent with and protect the participating agency at least to the same extent as the Region 10 ESC Terms and Conditions.

The remedies under the Contract are in addition to any other remedies that may be available under law or in equity. By submitting a Proposal, you agree to these Vendor violation and breach of contract terms.

Does vendor agree? _____ *TK*

(Initials of Authorized Representative)

2. Termination for Cause or Convenience:

When a participating agency expends federal funds, the participating agency reserves the right to immediately terminate any agreement in excess of \$10,000 resulting from this procurement process in the event of a breach or default of the agreement by Offeror in the event Offeror fails to: (1) meet schedules, deadlines, and/or delivery dates within the time specified in the procurement solicitation, contract, and/or a purchase order; (2) make any payments owed; or (3) otherwise perform in accordance with the contract and/or the procurement solicitation. participating agency also reserves the right to terminate the contract immediately, with written notice to offeror, for convenience, if participating agency believes, in its sole discretion that it is in the best

interest of participating agency to do so. Offeror will be compensated for work performed and accepted and goods accepted by participating agency as of the termination date if the contract is terminated for convenience of participating agency. Any award under this procurement process is not exclusive and participating agency reserves the right to purchase goods and services from other offerors when it is in participating agency's best interest.

Does vendor agree? TH
(Initials of Authorized Representative)

3. Equal Employment Opportunity:

Except as otherwise provided under 41 CFR Part 60, all participating agency purchases or contracts that meet the definition of "federally assisted construction contract" in 41 CFR Part 60-1.3 shall be deemed to include the equal opportunity clause provided under 41 CFR 60-1.4(b), in accordance with Executive Order 11246, "Equal Employment Opportunity" (30 FR 12319, 12935, 3 CFR Part, 1964-1965 Comp., p. 339), as amended by Executive Order 11375, "Amending Executive Order 11246 Relating to Equal Employment Opportunity," and implementing regulations at 41 CFR Part 60, "Office of Federal Contract Compliance Programs, Equal Employment Opportunity, Department of Labor."

The equal opportunity clause provided under 41 CFR 60-1.4(b) is hereby incorporated by reference. Vendor agrees that such provision applies to any participating agency purchase or contract that meets the definition of "federally assisted construction contract" in 41 CFR Part 60-1.3 and Vendor agrees that it shall comply with such provision.

Does vendor agree? TH
(Initials of Authorized Representative)

4. Davis-Bacon Act:

When required by Federal program legislation, Vendor agrees that, for all participating agency prime construction contracts/purchases in excess of \$2,000, Vendor shall comply with the Davis-Bacon Act (40 USC 3141-3144, and 3146-3148) as supplemented by Department of Labor regulations (29 CFR Part 5, "Labor Standards Provisions Applicable to Contracts Covering Federally Financed and Assisted Construction"). In accordance with the statute, Vendor is required to pay wages to laborers and mechanics at a rate not less than the prevailing wages specified in a wage determinate made by the Secretary of Labor. In addition, Vendor shall pay wages not less than once a week.

Current prevailing wage determinations issued by the Department of Labor are available at www.wdol.gov. Vendor agrees that, for any purchase to which this requirement applies, the award of the purchase to the Vendor is conditioned upon Vendor's acceptance of the wage determination.

Vendor further agrees that it shall also comply with the Copeland "Anti-Kickback" Act (40 USC 3145), as supplemented by Department of Labor regulations (29 CFR Part 3, "Contractors and Subcontractors on Public Building or Public Work Financed in Whole or in Part by Loans or Grants from the United States"). The Act provides that each contractor or subrecipient must be prohibited from inducing, by any means, any person employed in the construction, completion, or repair of public work, to give up any part of the compensation to which he or she is otherwise entitled.

Does vendor agree? TH

(Initials of Authorized Representative)

5. Contract Work Hours and Safety Standards Act:

Where applicable, for all participating agency contracts or purchases in excess of \$100,000 that involve the employment of mechanics or laborers, Vendor agrees to comply with 40 USC 3702 and 3704, as supplemented by Department of Labor regulations (29 CFR Part 5). Under 40 USC 3702 of the Act, Vendor is required to compute the wages of every mechanic and laborer on the basis of a standard work week of 40 hours. Work in excess of the standard work week is permissible provided that the worker is compensated at a rate of not less than one and a half times the basic rate of pay for all hours worked in excess of 40 hours in the work week. The requirements of 40 USC 3704 are applicable to construction work and provide that no laborer or mechanic must be required to work in surroundings or under working conditions which are unsanitary, hazardous or dangerous. These requirements do not apply to the purchases of supplies or materials or articles ordinarily available on the open market, or contracts for transportation or transmission of intelligence.

Does vendor agree? TH

(Initials of Authorized Representative)

6. Right to Inventions Made Under a Contract or Agreement:

If the participating agency's Federal award meets the definition of "funding agreement" under 37 CFR 401.2(a) and the recipient or subrecipient wishes to enter into a contract with a small business firm or nonprofit organization regarding the substitution of parties, assignment or performance or experimental, developmental, or research work under that "funding agreement," the recipient or subrecipient must comply with the requirements of 37 CFR Part 401, "Rights to Inventions Made by Nonprofit Organizations and Small Business Firms Under Government Grants, Contracts and Cooperative Agreements," and any implementing regulations issued by the awarding agency.

Vendor agrees to comply with the above requirements when applicable.

Does vendor agree? TH

(Initials of Authorized Representative)

7. Clean Air Act and Federal Water Pollution Control Act:

Clean Air Act (42 USC 7401-7671q.) and the Federal Water Pollution Control Act (33 USC 1251-1387), as amended –Contracts and subgrants of amounts in excess of \$150,000 must contain a provision that requires the non-Federal award to agree to comply with all applicable standards, orders, or regulations issued pursuant to the Clean Air Act (42 USC 7401-7671q.) and the Federal Water Pollution Control Act, as amended (33 USC 1251-1387). Violations must be reported to the Federal awarding agency and the Regional Office of the Environmental Protection Agency (EPA).

When required, Vendor agrees to comply with all applicable standards, orders, or regulations issued pursuant to the Clean Air Act and the Federal Water Pollution Control Act.

Does vendor agree? TH

(Initials of Authorized Representative)

8. Debarment and Suspension:

Debarment and Suspension (Executive Orders 12549 and 12689) – A contract award (see 2 CFR 180.220) must not be made to parties listed on the government-wide exclusions in the System for Award Management (SAM), in accordance with the OMB guidelines at 2 CFR 180 that implement Executive Orders 12549 (3 CFR Part 1966 Comp. p. 189) and 12689 (3CFR Part 1989 Comp. p. 235), “Debarment and Suspension.” SAM Exclusions contains the names of parties debarred, suspended, or otherwise excluded by agencies, as well as parties declared ineligible under statutory or regulatory authority other than Executive Order 12549.

Vendor certifies that Vendor is not currently listed on the government-wide exclusions in SAM, is not debarred, suspended, or otherwise excluded by agencies or declared ineligible under statutory or regulatory authority other than Executive Order 12549. Vendor further agrees to immediately notify the Cooperative and all participating agencies with pending purchases or seeking to purchase from Vendor if Vendor is later listed on the government-wide exclusions in SAM, or is debarred, suspended, or otherwise excluded by agencies or declared ineligible under statutory or regulatory authority other than Executive Order 12549.

Does vendor agree? _____ TH
(Initials of Authorized Representative)

9. Byrd Anti-Lobbying Amendment:

Byrd Anti-Lobbying Amendment (31 USC 1352) -- Vendors that apply or bid for an award exceeding \$100,000 must file the required certification. Each tier certifies to the tier above that it will not and has not used Federal appropriated funds to pay any person or organization for influencing or attempting to influence an officer or employee of any agency, a member of Congress, officer or employee of Congress, or an employee of a member of Congress in connection with obtaining any Federal contract, grant or any other award covered by 31 USC 1352. Each tier must also disclose any lobbying with non-Federal funds that takes place in connection with obtaining any Federal award. Such disclosures are forwarded from tier to tier up to the non-Federal award. As applicable, Vendor agrees to file all certifications and disclosures required by, and otherwise comply with, the Byrd Anti-Lobbying Amendment (31 USC 1352).

Does vendor agree? _____ TH
(Initials of Authorized Representative)

10. Procurement of Recovered Materials:

For participating agency purchases utilizing Federal funds, Vendor agrees to comply with Section 6002 of the Solid Waste Disposal Act, as amended by the Resource Conservation and Recovery Act where applicable and provide such information and certifications as a participating agency may require to confirm estimates and otherwise comply. The requirements of Section 6002 include procuring only items designated in guidelines of the Environmental Protection Agency (EPA) at 40 CFR Part 247 that contain the highest percentage of recovered materials practicable, consistent with maintaining a satisfactory level of competition, where the purchase price of the item exceeds \$10,000 or the value of the quantity acquired during the preceding fiscal year exceeded \$10,000; procuring solid waste management services in a manner that maximizes energy and resource recovery,

and establishing an affirmative procurement program for procurement of recovered materials identified in the EPA guidelines.

Does vendor agree? TH

(Initials of Authorized Representative)

11. Profit as a Separate Element of Price:

For purchases using federal funds in excess of \$150,000, a participating agency may be required to negotiate profit as a separate element of the price. See, 2 CFR 200.323(b). When required by a participating agency, Vendor agrees to provide information and negotiate with the participating agency regarding profit as a separate element of the price for a particular purchase. However, Vendor agrees that the total price, including profit, charged by Vendor to the participating agency shall not exceed the awarded pricing, including any applicable discount, under Vendor's Cooperative Contract.

Does vendor agree? TH

(Initials of Authorized Representative)

12. Prohibition on Certain Telecommunications and Video Surveillance Services or Equipment

Vendor agrees that recipients and subrecipients are prohibited from obligating or expending loan or grant funds to procure or obtain, extend or renew a contract to procure or obtain, or enter into a contract (or extend or renew a contract) to procure or obtain equipment, services, or systems that uses covered telecommunications equipment or services as a substantial or essential component of any system, or as critical technology as part of any system from companies described in Public Law 115-232, section 889. Telecommunications or video surveillance equipment or services produced or provided by an entity that the Secretary of Defense, in consultation with the Director of the National Intelligence or the Director of the Federal Bureau of Investigation, reasonably believes to be an entity owned or controlled by, or otherwise connected to, the government of a covered foreign country are also prohibited.

Does vendor agree? TH

(Initials of Authorized Representative)

13. General Compliance and Cooperation with Participating Agencies:

In addition to the foregoing specific requirements, Vendor agrees, in accepting any Purchase Order from a participating agency, it shall make a good faith effort to work with participating agencies to provide such information and to satisfy such requirements as may apply to a particular participating agency purchase or purchases including, but not limited to, applicable recordkeeping and record retention requirements.

Does vendor agree? TH

(Initials of Authorized Representative)

14. Applicability to Subcontractors

Offeror agrees that all contracts it awards pursuant to the Contract shall be bound by the foregoing terms and conditions.

Does vendor agree? TH

(Initials of Authorized Representative)

By signature below, I certify that the information in this form is true, complete, and accurate and that I am authorized by my company to make this certification and all consents and agreements contained herein.

RWC Group

Company Name

[Signature]

Signature of Authorized Company Official

Thomas Hartman

Printed Name

General Manager

Title

3-10-23

Date

PROPOSAL FORM 13: ADDITIONAL ARIZONA CONTRACTOR REQUIREMENTS

AZ Compliance with Federal and state requirements: Contractor agrees when working on any federally assisted projects with more than \$2,000.00 in labor costs, to comply with all federal and state requirements, as well as Equal Opportunity Employment requirements and all other federal and state laws, statutes, etc. Contractor agrees to post wage rates at the work site and submit a copy of their payroll to the member for their files. Contractor must retain records for three years to allow the federal grantor agency access to these records, upon demand. Contractor also agrees to comply with the Arizona Executive Order 75-5, as amended by Executive Order 99-4.

When working on contracts funded with Federal Grant monies, contractor additionally agrees to comply with the administrative requirements for grants, and cooperative agreements to state, local and federally recognized Indian Tribal Governments.

AZ Compliance with workforce requirements: Pursuant to ARS 41-4401, Contractor and subcontractor(s) warrant their compliance with all federal and state immigration laws and regulations that relate to their employees, and compliance with ARS 23-214 subsection A, which states, "...every employer, after hiring an employee, shall verify the employment eligibility of the employee through the E-Verify program" Region 10 ESC reserves the right to cancel or suspend the use of any contract for violations of immigration laws and regulations. Region 10 ESC and its members reserve the right to inspect the papers of any contractor or subcontract employee who works under this contract to ensure compliance with the warranty above.

AZ Contractor Employee Work Eligibility: By entering into this contract, contractor agrees and warrants compliance with A.R.S. 41-4401, A.R.S. 23-214, the Federal Immigration and Nationality Act (FINA), and all other Federal immigration laws and regulations. Region 10 ESC and/or Region 10 ESC members may request verification of compliance from any contractor or sub contractor performing work under this contract. Region 10 ESC and Region 10 ESC members reserve the right to confirm compliance. In the event that Region 10 ESC or Region 10 ESC members suspect or find that any contractor or subcontractor is not in compliance, Region 10 ESC may pursue any and all remedies allowed by law, including but not limited to suspension of work, termination of contract, suspension and/or debarment of the contractor. All cost associated with any legal action will be the responsibility of the contractor.

AZ Non-Compliance: All federally assisted contracts to members that exceed \$10,000.00 may be terminated by the federal grantee for noncompliance by contractor. In projects that are not federally funded, Respondent must agree to meet any federal, state or local requirements as necessary. In addition, if compliance with the federal regulations increases the contract costs beyond the agreed on costs in this solicitation, the additional costs may only apply to the portion of the work paid by the federal grantee.

Registered Sex Offender Restrictions (Arizona): For work to be performed at an Arizona school, contractor agrees that no employee or employee of a subcontractor who has been adjudicated to be a registered sex offender will perform work at any time when students are present, or reasonably expected to be present. Contractor agrees that a violation of this condition shall be considered a material breach and may result in the cancellation of the purchase order at the Region 10 ESC member's discretion. Contractor must identify any additional costs associated with compliance to this term. If no costs are specified, compliance with this term will be provided at no additional charge.

Offshore Performance of Work Prohibited: Due to security and identity protection concerns, direct services under this contract shall be performed within the borders of the United States.

Terrorism Country Divestments: In accordance with A.R.S. 35-392, Region 10 ESC and Region 10 ESC members are prohibited from purchasing from a company that is in violation of the Export Administration Act. By entering into the contract, contractor warrants compliance with the Export Administration Act.

The undersigned hereby accepts and agrees to comply with all statutory compliance and notice requirements listed in this document.



Signature of Respondent



Date

PROPOSAL FORM 14: OWNERSHIP DISCLOSURE FORM (N.J.S. 52:25-24.2)

Pursuant to the requirements of P.L. 1999, Chapter 440 effective April 17, 2000 (Local Public Contracts Law), the Respondent shall complete the form attached to these specifications listing the persons owning 10 percent (10%) or more of the firm presenting the proposal.

Company Name: RWC International, LTD
Street: 1000 N. 75th Ave
City, State, Zip Code: PHX, AZ 85043

Complete as appropriate:

I _____, certify that I am the sole owner of _____, that there are no partners and the business is not incorporated, and the provisions of N.J.S. 52:25-24.2 do not apply.

OR:

I _____, a partner in _____, do hereby certify that the following is a list of all individual partners who own a 10% or greater interest therein. I further certify that if one (1) or more of the partners is itself a corporation or partnership, there is also set forth the names and addresses of the stockholders holding 10% or more of that corporation's stock or the individual partners owning 10% or greater interest in that partnership.

OR:

I Beth Monick, an authorized representative of RWC International, LTD, a corporation, do hereby certify that the following is a list of the names and addresses of all stockholders in the corporation who own 10% or more of its stock of any class. I further certify that if one (1) or more of such stockholders is itself a corporation or partnership, that there is also set forth the names and addresses of the stockholders holding 10% or more of the corporation's stock or the individual partners owning a 10% or greater interest in that partnership.

(Note: If there are no partners or stockholders owning 10% or more interest, indicate none.)

Name	Address	Interest
------	---------	----------

SEE ATTACHED

I further certify that the statements and information contained herein, are complete and correct to the best of my knowledge and belief.

Beth Monick, Corporate Controller
Authorized Signature and Title

3/8/23
Date

PROPOSAL FORM 15: NON-COLLUSION AFFIDAVIT

Company Name:

Street:

City, State, Zip Code:

* Did we receive the wrong page. We reside in Arizona Didn't think this page applied.

State of New Jersey

County of _____

I, _____ of the _____
Name City

in the County of _____, State of _____ of full age, being duly sworn according to law on my oath depose and say that:

I am the _____ of the firm of _____
Title Company Name

the Respondent making the Proposal for the goods, services or public work specified under the Harrison Township Board of Education attached proposal, and that I executed the said proposal with full authority to do so; that said Respondent has not directly or indirectly entered into any agreement, participated in any collusion, or otherwise taken any action in restraint of free, competitive bidding in connection with the above proposal, and that all statements contained in said bid proposal and in this affidavit are true and correct, and made with full knowledge that the Harrison Township Board of Education relies upon the truth of the statements contained in said bid proposal and in the statements contained in this affidavit in awarding the contract for the said goods, services or public work.

I further warrant that no person or selling agency has been employed or retained to solicit or secure such contract upon an agreement or understanding for a commission, percentage, brokerage or contingent fee, except bona fide employees or bona fide established commercial or selling agencies maintained by

Company Name

Authorized Signature & Title

Subscribed and sworn before me _____

this _____ day of _____, 20____

Notary Public of New Jersey
My commission expires _____, 20____

SEAL

* We dont do business in New Jersey.

PROPOSAL FORM 16: AFFIRMATIVE ACTION AFFIDAVIT (P.L. 1975, C.127)

Company Name: _____

Street: _____

City, State, Zip Code: _____

Bid Proposal Certification:

Indicate below your compliance with New Jersey Affirmative Action regulations. Your proposal will be accepted even if you are not in compliance at this time. No contract and/or purchase order may be issued, however, until all Affirmative Action requirements are met.

Required Affirmative Action Evidence:

Procurement, Professional & Service Contracts (Exhibit A)

Vendors must submit with proposal:

- 1. A photo copy of their Federal Letter of Affirmative Action Plan Approval _____
OR
- 2. A photo copy of their Certificate of Employee Information Report _____
OR
- 3. A complete Affirmative Action Employee Information Report (AA302) _____

Public Work – Over \$50,000 Total Project Cost:

A. No approved Federal or New Jersey Affirmative Action Plan. We will complete Report Form AA201-A upon receipt from the Harrison Township Board of Education _____

B. Approved Federal or New Jersey Plan – certificate enclosed _____

I further certify that the statements and information contained herein, are complete and correct to the best of my knowledge and belief.

Authorized Signature and Title

Date

P.L. 1995, c. 127 (N.J.A.C. 17:27)

MANDATORY AFFIRMATIVE ACTION LANGUAGE

PROCUREMENT, PROFESSIONAL AND SERVICE CONTRACTS

During the performance of this contract, the contractor agrees as follows:

The contractor or subcontractor, where applicable, will not discriminate against any employee or applicant for employment because of age, race, creed, color, national origin, ancestry, marital status, sex, affectional or sexual orientation. The contractor will take affirmative action to ensure that such applicants are recruited and employed, and that employees are treated during employment, without regard to their age, race, creed, color,

national origin, ancestry, marital status, sex, affectional or sexual orientation. Such action shall include, but not be limited to the following: employment, upgrading, demotion, or transfer; recruitment or recruitment advertising; layoff or termination; rates of pay or other forms of compensation; and selection for training, including apprenticeship. The contractor agrees to post in conspicuous places, available to employees and applicants for employment, notices to be provided by the Public Agency Compliance Officer setting forth provisions of this non-discrimination clause.

The contractor or subcontractor, where applicable will, in all solicitations or advertisement for employees placed by or on behalf of the contractor, state that all qualified applicants will receive consideration for employment without regard to age, race, creed, color, national origin, ancestry, marital status, sex, affectional or sexual orientation.

The contractor or subcontractor, where applicable, will send to each labor union or representative of workers with which it has a collective bargaining agreement or other contract or understanding, a notice, to be provided by the agency contracting officer advising the labor union or workers' representative of the contractor's commitments under this act and shall post copies of the notice in conspicuous places available to employees and applicants for employment.

The contractor or subcontractor, where applicable, agrees to comply with any regulations promulgated by the Treasurer pursuant to P.L. 1975, c. 127, as amended and supplemented from time to time and the Americans with Disabilities Act.

The contractor or subcontractor agrees to attempt in good faith to employ minority and female workers trade consistent with the applicable county employment goal prescribed by N.J.A.C. 17:27-5.2 promulgated by the Treasurer pursuant to P.L. 1975, C.127, as amended and supplemented from time to time or in accordance with a binding determination of the applicable county employment goals determined by the Affirmative Action Office pursuant to N.J.A.C. 17:27-5.2 promulgated by the Treasurer pursuant to P.L. 1975, C.127, as amended and supplemented from time to time.

The contractor or subcontractor agrees to inform in writing appropriate recruitment agencies in the area, including employment agencies, placement bureaus, colleges, universities, labor unions, that it does not discriminate on the basis of age, creed, color, national origin, ancestry, marital status, sex, affectional or sexual orientation, and that it will discontinue the use of any recruitment agency which engages in direct or indirect discriminatory practices.

The contractor or subcontractor agrees to revise any of its testing procedures, if necessary, to assure that all personnel testing conforms with the principles of job-related testing, as established by the statutes and court decisions of the state of New Jersey and as established by applicable Federal law and applicable Federal court decisions.

The contractor or subcontractor agrees to review all procedures relating to transfer, upgrading, downgrading and lay-off to ensure that all such actions are taken without regard to age, creed, color, national origin, ancestry, marital status, sex, affectional or sexual orientation, and conform with the applicable employment goals, consistent with the statutes and court decisions of the State of New Jersey, and applicable Federal law and applicable Federal court decisions.

The contractor and its subcontractors shall furnish such reports or other documents to the Affirmative Action Office as may be requested by the office from time to time in order to carry out the purposes of these regulations, and public agencies shall furnish such information as may be requested by the Affirmative Action Office for conducting a compliance investigation pursuant to Subchapter 10 of the Administrative Code (NJAC 17:27).

We don't do business in New Jersey.

Signature of Procurement Agent

PROPOSAL FORM 17: C. 271 POLITICAL CONTRIBUTION DISCLOSURE FORM

Public Agency Instructions

This page provides guidance to public agencies entering into contracts with business entities that are required to file Political Contribution Disclosure forms with the agency. **It is not intended to be provided to contractors.** What follows are instructions on the use of form local units can provide to contractors that are required to disclose political contributions pursuant to N.J.S.A. 19:44A-20.26 (P.L. 2005, c. 271, s.2). Additional information is available in Local Finance Notice 2006-1 (https://www.nj.gov/dca/divisions/dlgs/resources/lfns_2006.html).

1. The disclosure is required for all contracts in excess of \$17,500 that are **not awarded** pursuant to a "fair and open" process (N.J.S.A. 19:44A-20.7).
2. Due to the potential length of some contractor submissions, the public agency should consider allowing data to be submitted in electronic form (i.e., spreadsheet, pdf file, etc.). Submissions must be kept with the contract documents or in an appropriate computer file and be available for public access. **The form is worded to accept this alternate submission.** The text should be amended if electronic submission will not be allowed.
3. The submission must be **received from the contractor and** on file at least 10 days prior to award of the contract. Resolutions of award should reflect that the disclosure has been received and is on file.
4. The contractor must disclose contributions made to candidate and party committees covering a wide range of public agencies, including all public agencies that have elected officials in the county of the public agency, state legislative positions, and various state entities. The Division of Local Government Services recommends that contractors be provided a list of the affected agencies. This will assist contractors in determining the campaign and political committees of the officials and candidates affected by the disclosure.
 - a) The Division has prepared model disclosure forms for each county. They can be downloaded from the "County PCD Forms" link on the Pay-to-Play web site at https://www.state.nj.us/dca/divisions/dlgs/programs/pay_2_play.html They will be updated from time-to-time as necessary.
 - b) A public agency using these forms **should edit them to properly reflect the correct legislative district(s)**. As the forms are county-based, **they list all legislative districts** in each county. **Districts that do not represent the public agency should be removed from the lists.**
 - c) Some contractors may find it easier to provide a single list that covers all contributions, regardless of the county. These submissions are appropriate and should be accepted.
 - d) The form may be used "as-is", subject to edits as described herein.
 - e) The "Contractor Instructions" sheet is intended to be provided with the form. It is recommended that the Instructions and the form be printed on the same piece of paper. The form notes that the Instructions are printed on the back of the form; where that is not the case, the text should be edited accordingly.
 - f) The form is a Word document and can be edited to meet local needs, and posted for download on web sites, used as an e-mail attachment, or provided as a printed document.
5. It is recommended that the contractor also complete a "Stockholder Disclosure Certification." This will assist the local unit in its obligation to ensure that contractor did not make any prohibited contributions to the committees listed on the Business Entity Disclosure Certification in the 12 months prior to the contract. (See Local Finance Notice 2006-7 for additional information on this obligation) A sample Certification form is part of this package and the instruction to complete it is included in the Contractor Instructions. **NOTE: This section is not applicable to Boards of Education.**

C. 271 POLITICAL CONTRIBUTION DISCLOSURE FORM

Contractor Instructions

Business entities (contractors) receiving contracts from a public agency that are NOT awarded pursuant to a "fair and open" process (defined at N.J.S.A. 19:44A-20.7) are subject to the provisions of P.L. 2005, c. 271, s.2 (N.J.S.A. 19:44A-20.26). This law provides that 10 days prior to the award of such a contract, the contractor shall disclose contributions to:

1. any State, county, or municipal committee of a political party
2. any legislative leadership committee*
3. any continuing political committee (a.k.a., political action committee)
4. any candidate committee of a candidate for, or holder of, an elective office:
 1. of the public entity awarding the contract
 2. of that county in which that public entity is located
 3. of another public entity within that county
 4. or of a legislative district in which that public entity is located or, when the public entity is a county, of any legislative district which includes all or part of the county. The disclosure must list reportable contributions to any of the committees that exceed \$300 per election cycle that were made during the 12 months prior to award of the contract. See N.J.S.A. 19:44A-8 and 19:44A-16 for more details on reportable contributions.

N.J.S.A. 19:44A-20.26 itemizes the parties from whom contributions must be disclosed when a business entity is not a natural person. This includes the following:

5. individuals with an "interest" ownership or control of more than 10% of the profits or assets of a business entity or 10% of the stock in the case of a business entity that is a corporation for profit
6. all principals, partners, officers, or directors of the business entity or their spouses
7. any subsidiaries directly or indirectly controlled by the business entity
8. IRS Code Section 527 New Jersey based organizations, directly or indirectly controlled by the business entity and filing as continuing political committees, (PACs). When the business entity is a natural person, "a contribution by that person's spouse or child, residing therewith, shall be deemed to be a contribution by the business entity." [N.J.S.A. 19:44A-20.26(b)] The contributor must be listed on the disclosure. Any business entity that fails to comply with the disclosure provisions shall be subject to a fine imposed by ELEC in an amount to be determined by the Commission which may be based upon the amount that the business entity failed to report. The enclosed list of agencies is provided to assist the contractor in identifying those public agencies whose elected official and/or candidate campaign committees are affected by the disclosure requirement. It is the contractor's responsibility to identify the specific committees to which contributions may have been made and need to be disclosed. The disclosed information may exceed the minimum requirement. The enclosed form, a content-consistent facsimile, or an electronic data file containing the required details (along with a signed cover sheet) may be used as the contractor's submission and is disclosable to the public under the Open Public Records Act. The contractor must also complete the attached Stockholder Disclosure Certification. This will assist the agency in meeting its obligations under the law.

NOTE: This section does not apply to Board of Education contracts.

* N.J.S.A. 19:44A-3(s): "The term "legislative leadership committee" means a committee established, authorized to be established, or designated by the President of the Senate, the Minority Leader of the Senate, the Speaker

List of Agencies with Elected Officials Required for Political Contribution Disclosure

N.J.S.A. 19:44A-20.26

County Name:

State: Governor, and Legislative Leadership Committees

Legislative District #s:

State Senator and two members of the General Assembly per district.

County:

Freeholders

County Clerk

Sheriff

{County Executive}

Surrogate

Municipalities (Mayor and members of governing body, regardless of title):

USERS SHOULD CREATE THEIR OWN FORM, OR DOWNLOAD FROM WWW.NJ.GOV/DCA/LGS/P2P A COUNTY-BASED, CUSTOMIZABLE FORM.

PROPOSAL FORM 18: STOCKHOLDER DISCLOSURE CERTIFICATION

Name of Business:

I certify that the list below contains the names and home addresses of all stockholders holding 10% or more of the issued and outstanding stock of the undersigned.

OR

I certify that no one stockholder owns 10% or more of the issued and outstanding stock of the undersigned.

Check the box that represents the type of business organization:

Partnership

Sole Proprietorship

Limited Liability Partnership

Corporation

Limited Partnership

Subchapter S Corporation

Limited Liability Corporation

Sign and notarize the form below, and, if necessary, complete the stockholder list below.

Stockholders:

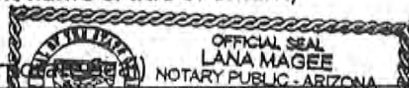
Name:	Name:
Home Address:	Home Address:
SEE ATTACHED	
Name:	Name:
Home Address:	Home Address:
Name:	Name:
Home Address:	Home Address:
Subscribed and sworn before me this <u>8th</u> day of <u>MARCH</u> , 2 <u>023</u>	<u>Lana Magee</u> (Affiant)
(Notary Public)	<u>Lana Magee, Notary Public</u> (Print name & title of affiant)
My Commission expires: <u>05-24-2023</u>	(Corporation) 

RWC INTERNATIONAL, LTD -- OWNERS

NAME	HOME ADDRESS	CITY	STATE	ZIP	% OWNERSHIP SHARES
The Rudge L. Hefner and Catherine A. Hefner 2012 Trust UTA 8-18-2012	3722 E. JUNIPER CR	MESA	AZ	85205	10.0% (172,222 SHARES)
Robert W Cunningham, Jr	19102 CALLAWAY CIRCLE	HUNTINGTON BEACH	CA	92648	16.316% (281,008 SHARES)
Chareese C. Reid	2344 KACHESS RD	LIBERTY LAKE	WA	99016	16.316% (281,008 SHARES)
Rowland W Cunningham	8721 43rd PL SW	SEATTLE	WA	98136	16.316% (281,008 SHARES)
Paige C. Hughes	2092 S. NAVAJO CT.	CHANDLER	AZ	85286	16.316% (281,008 SHARES)
Richard W Cunningham	2779 E. WYATT WAY	GILBERT	AZ	85297	16.316% (281,008 SHARES)

PROPOSAL FORM 19: GENERAL TERMS AND CONDITIONS ACCEPTANCE FORM

Signature on the Vendor Contract Signature form certifies complete acceptance of the General Terms and Conditions in this solicitation, except as noted below (additional pages may be attached, if necessary).

Check one of the following responses to the General Terms and Conditions:

We take no exceptions/deviations to the general terms and conditions

(Note: If none are listed below, it is understood that no exceptions/deviations are taken.)

We take the following exceptions/deviations to the general terms and conditions. All exceptions/deviations must be clearly explained. Reference the corresponding general terms and conditions that you are taking exceptions/deviations to. Clearly state if you are adding additions terms and conditions to the general terms and conditions. Provide details on your exceptions/deviations below:

(Note: Unacceptable exceptions shall remove your proposal from consideration for award. Region 10 ESC shall be the sole judge on the acceptance of exceptions/deviations and the decision shall be final.)

PROPOSAL FORM 20: EQUALIS GROUP ADMINISTRATION AGREEMENT

Requirements for Master Agreement To be administered by Equalis Group

Attachment A, Equalis Group Administrative Agreement is used in administering Master Agreements with Region 10 and is preferred by Equalis Group. Redlined copies of this agreement should not be submitted with the response. Should a respondent be recommended for award, this agreement will be negotiated and executed between Equalis Group and the respondent. **Respondents must select one of the following options for submitting their response.**

- Respondent agrees to all terms and conditions outlined in each of the Administration Agreement.
- Respondent wishes to negotiate directly with Equalis Group on terms and conditions outlined in the Administration Agreement. Negotiations will commence after sealed Proposals are opened and Region 10 has determined the respondent met all requirements in their response and may be eligible for award.

PROPOSAL FORM 21: OPEN RECORDS POLICY ACKNOWLEDGEMENT AND ACCEPTANCE
OPEN RECORDS POLICY ACKNOWLEDGMENT AND ACCEPTANCE

Be advised that all information and documents submitted will be subject to the Public Information Act requirements governed by Chapter 552 of the Texas Government Code.

Because contracts are awarded by a Texas governmental entity, all responses submitted are subject to release as public information after contracts are executed. If a Respondent believes that its response, or parts of its response, may be exempted from disclosure to the public, the Respondent must specify page-by-page and line-by-line the parts of the response, which it believes, are exempted from disclosure. In addition, the Respondent must specify which exception(s) are applicable and provide detailed reasons to substantiate the exception(s). Respondent must provide this information on the "Acknowledgement and Acceptance to Region 10 ESC's Public Information Act Policy" form found on the next page of this solicitation. Any information that is unmarked will be considered public information and released, if requested under the Public Information Act.

The determination of whether information is confidential and not subject to disclosure is the duty of the Office of Attorney General (OAG). Region 10 ESC must provide the OAG with the information requested in order for the OAG to render an opinion. In such circumstances, Respondent will be notified in writing that the material has been requested and delivered to the OAG. Respondent will have an opportunity to make arguments to the OAG in writing regarding the exception(s) to the TPIA that permit the information to be withheld from public disclosure. Respondents are advised that such arguments to the OAG must be specific and well-reasoned--vague and general claims to confidentiality by the Respondent are generally not acceptable to the OAG. Once the OAG opinion is received by Region 10 ESC, Region 10 ESC must comply with the opinions of the OAG. Region 10 ESC assumes no responsibility for asserting legal arguments on behalf of any Respondent. Respondents are advised to consult with their legal counsel concerning disclosure issues resulting from this procurement process and to take precautions to safeguard trade secrets and other proprietary information.

After completion of award, these documents will be available for public inspection.

Signature below certifies complete acceptance of Region 10 ESC's Open Records Policy, except as noted below (additional pages may be attached, if necessary). Check one of the following responses to the Acknowledgment and Acceptance of Region 10 ESC's Open Records Policy below:

We acknowledge Region 10 ESC's Public Information Act policy and declare that no information submitted with this proposal, or any part of our proposal, is exempt from disclosure under the Public Information Act.

(Note: All information believed to be a trade secret or proprietary must be listed below. It is further understood that failure to identify such information, in strict accordance with the instructions below, will result in that information being considered public information and released, if requested under the Public Information Act.)

We declare the following information to be a trade secret or proprietary and exempt from disclosure under the Public Information Act.

(Note: Respondent must specify page-by-page and line-by-line the parts of the response, which it believes, are exempt. In addition, Respondent must specify which exception(s) are applicable and provide detailed reasons to substantiate the exception(s).)

3-10-23
Date

[Signature] General Manager
Authorized Signature & Title

PROPOSAL FORM 22: VENDOR CONTRACT AND SIGNATURE FORM

The undersigned hereby proposes and agrees to furnish goods and/or services in strict compliance with the terms, specifications and conditions at the prices proposed within response unless noted in writing. The undersigned further certifies that he/she is an officer of the company and has authority to negotiate and bind the company named below and has not prepared this proposal in collusion with any other Respondent and that the contents of this proposal as to prices, terms or conditions of said proposal have not been communicated by the undersigned nor by any employee or agent to any person engaged in this type of business prior to the official opening of this proposal.

VENDORS MUST SUBMIT THIS FORM COMPLETED AND SIGNED WITH THEIR RESPONSE TO BE CONSIDERED

Company name DWC Group
Address 600 N. 75th Avenue
City/State/Zip Phoenix AZ 85043
Telephone No. 602-377-4401
Fax No. _____
Email address thartman@dwcgroup.com
Printed name Thomas Hartman
Position with company General Manager
Authorized signature 

Term of contract May 1, 2023 to April 30, 2026

Unless otherwise stated, all contracts are for a period of three (3) years with an option to renew annually for an additional two (2) years if agreed to by Region 10 ESC. Vendor shall honor all administrative fees for any sales made based on the contract whether renewed or not.



Region 10 ESC Authorized Agent

4/19/23

Date

Dr. Rickey Williams

Print Name

Equalis Group Contract Number R10-1148B



Did you sign the vendor contract and signature form? **If not, your Proposal will be rejected.**

Region 10 will negotiate any exceptions and both parties will agree upon which exceptions will be accepted or altered before the Region 10 board votes to accept or reject the proposals.

Date: 3/10/23
Quote Valid Until:
Prepared By: TOM HARTMAN



Name:
Organization: EQUALIS GROUP
Address:
City, State ZIP:
Phone:

YEAR:	2024
MAKE:	GREENPOWER
MODEL:	MEGA BEAST
CAPACITY:	90
STOCK #'S:	RWCGPBEAST-1

		\$ 600,000.00
INCLUDES 3 CAMERA SYSTEM AND DVR INCLUDES AC SYSTEM EV FREEBLOW		
TRADE BUS #:		Trade Total: \$ -
Pre Tax Sub Total:		\$ 600,000.00
Sales Tax ():		\$ -
Local Delivery Charge:	0	\$ -
TOTAL PRICE:		\$ 600,000.00

DWC6PBEAST-1 EV 387 kW 90 passenger

Model Profile

2023 GreenPower BEAST School Bus 90

APPLICATION: School Transportation

DIMENSION: Wheelbase: 240"

Electric Motor: DANA TM4 permanent magnet synchronous motor with cooling system, with retarder function.

Base Horse Power: 469horse power(350kW) max. 261.5 horse power(1387kW) max 30 min.

BATTERY: 614.4V/315AH, 387 kWh with 6 packs, Lithium iron phosphate battery with Battery Management System (BMS), and Battery Thermal Management System (TMS)

CHARGE: CCS-1 DC Fast Charger (up to 50 kW), CCS-1 AC Level 2 (up to 19.2 kW)

AXLE, FRONT NON-DRIVING: Front disc brake axle, rated loading 14330-lb with disc brake

AXLE, REAR: Rear disc brake axle, rated loading 28,660-lb with disc brake

TIRE, FRONT: (2) 12R22.5 tubeless radial tire

TIRE, REAR: (4) 12R22.5 tubeless radial tire

RIM: {Alcoa} Aluminum alloy rim, Dual bright with spare tire and rim

SUSPENSION, REAR, AIR: Firestone air bags, shock absorber

BRAKE: Service brake: Knorr Pneumatic Disc dual circuit full air brake, Parking brake: storage energy spring braking, acting on rear axle. WABCO brand of all components for braking system

PAINT: AXALTA N5898 EF School bus yellow

Vehicle Specifications
2023 GreenPower School Bus 90

Code	Description
CV-SSB-19-CB-001	Base Chassis, Wheelbase: 240"
CV-SSB-19-CB-002	BUMPER, Chassis Integrated Bumpers
CV-SSB-19-CB-003A	BATTERY, 614.4V/315AH, 387kWh with 6 packs, Lithium iron phosphate battery with Battery Management System (BMS)
CV-SSB-19-CB-004	AXLE, FRONT NON-DRIVING: Front Disc Brake Axle, Rated Loading 14330-lb with Disc Brake
CV-SSB-19-CB-005	SUSPENSION, FRONT, Air Suspension
CV-SSB-19-CB-006	BRAKE, Service Brake: Pneumatic Dual Circuit Full Air Brake, Parking brake: Storage Energy Spring Braking, Acting on Rear Axle. WABCO Brand of All Components for Braking System
CV-SSB-19-CB-007	BRAKE, Pneumatic Disc Brakes, Front and Rear Axles, with ABS
CV-SSB-19-CB-008	BRAKE, Regenerative Braking
CV-SSB-19-CB-009	Manual Air Drains for All Five Air Tanks- Full Drain for Brake Check
CV-SSB-19-CB-010	Dual Air Gauges for Performing Required Daily CHP Full Drain Air Brake Test
CV-SSB-19-CB-011	5-IN-1 UNIT, Control Unit, DC/AC Convertor, High Voltage Distribution System
CV-SSB-19-CB-012	CHASSIS, 1130300226, Water Hose (Without Insulation Pipe)
CV-SSB-19-CB-013	CHASSIS, 1290100003, Rubber Cushion
CV-SSB-19-CB-014	CHASSIS, 1340600300, Steering Oil Inlet Pipe Assembly
CV-SSB-19-CB-015	CHASSIS, 1340600321, Steering Return Pipe Assembly
CV-SSB-19-CB-016	CHASSIS, 1930460010, Acceleration/Brake Pedal Pad
CV-SSB-19-CB-017	CHASSIS, 2110800347, Electronic Accelerator Pedal
CV-SSB-19-CB-018	CHASSIS, 2130200004, Support Cushion on The Water Tank
CV-SSB-19-CB-019	CHASSIS, 2130700008, Water Pump (Drive Motor Cooling)
CV-SSB-19-CB-020	CHASSIS, 2131100026, Plastic Expansion Tank for Electric Vehicles
CV-SSB-19-CB-021	CHASSIS, 2131300052, Electronic Fan
CV-SSB-19-CB-023	CHASSIS, 2290100006, Vibration Proof Rubber Mat
CV-SSB-19-CB-024	CHASSIS, 2310200122, Front Wheel Sleeve Nut
CV-SSB-19-CB-025	CHASSIS, 2310200123, Rear Wheel Sleeve Nut
CV-SSB-19-CB-026	CHASSIS, 2310500006, Chassis Spare Tire Lifter
CV-SSB-19-CB-027	CHASSIS, 2340810023, Power Steering Oil Tank Assembly
CV-SSB-19-CB-028	CHASSIS, 2341500005, Angular Actuator
CV-SSB-19-CB-029	CHASSIS, 2350000007, Silencer - Wabco
CV-SSB-19-CB-030	CHASSIS, 2350500016, Brake Master Cylinder
CV-SSB-19-CB-031	CHASSIS, 2351400005, Pressure Limiting Valve
CV-SSB-19-CB-032	CHASSIS, 2351800009, Relay Valve
CV-SSB-19-CB-033	CHASSIS, 2351800014, Differential Relay Valve
CV-SSB-19-CB-034	CHASSIS, 2352000001, Pneumatic Signal Light Switch
CV-SSB-19-CB-035	CHASSIS, 2352600011, Manual Valve
CV-SSB-19-CB-036	CHASSIS, 2355000019, Wabco ABS

CV-SSB-19-CB-037	CHASSIS, 2355500031, Condenser
CV-SSB-19-CB-038	CHASSIS, 2355500057, Air Dryer
CV-SSB-19-CB-039	CHASSIS, 2356100104, Brake Hose
CV-SSB-19-CB-041	CHASSIS, 2357300014, Four Circuit Protection Valve
CV-SSB-19-CB-042	CHASSIS, 2360000083, Electronic Gear Switch
CV-SSB-19-CB-043	CHASSIS, 2370000701, 4kW Air Compressor
CV-SSB-19-CB-044	CHASSIS, 2370000734, Double Source Electric Pump
CV-SSB-19-CB-045	CHASSIS, 2370000736, 24V Controller
CV-SSB-19-CB-046	CHASSIS, 2371100192, Electrical Control Box
CV-SSB-19-CB-047	CHASSIS, 2372101010, Electric Horn
CV-SSB-19-CB-048	CHASSIS, 2373500003, Ordinary Relay (24V/5 Foot 2914)
CV-SSB-19-CB-049	CHASSIS, 2373510003, Wiper Relay
CV-SSB-19-CB-050	CHASSIS, 2373610084, Manual Power Main Switch A (Left Exit)
CV-SSB-19-CB-051	CHASSIS, 2379900004, Brake Switch
CV-SSB-19-CB-052	CHASSIS, 2381900018, Reversing Buzzer (Amp Plug-In 282044-1 (M)) - Yx
CV-SSB-19-CB-053	CHASSIS, 2387500018, Air Pressure Sensor (Small Housing Stainless Steel)
CV-SSB-19-CB-054	CHASSIS, 2391000200, Automatic Fire Extinguisher 3/Set (With Manual Push Button Switch, Start Feedback Device)
CV-SSB-19-CB-055	CHASSIS, 2406200001, Copper Preparation Line
CV-SSB-19-CB-062	CHASSIS, 2425000012, Centralized Lubrication
CV-SSB-19-CB-063	CHASSIS, 2810126004, Water Hose
CV-SSB-19-CB-064	CHASSIS, 2810142359, Water Hose
CV-SSB-19-CB-065	CHASSIS, 3050300004, Oil Resistant Hose*
CV-SSB-19-CB-068	CHASSIS, 5100002805, Front Suspension Left Bracket
CV-SSB-19-CB-069	CHASSIS, 5100002806, Front Suspension Right Bracket
CV-SSB-19-CB-070	CHASSIS, 5120000099, Gasket
CV-SSB-19-CB-071	CHASSIS, 5130800203, Upper Gasket
CV-SSB-19-CB-072	CHASSIS, 5130801596, Water Tank Support Rod
CV-SSB-19-CB-073	CHASSIS, 5130803494, Electrician Bracket
CV-SSB-19-CB-074	CHASSIS, 5130805750, Water Pump Inlet Joint
CV-SSB-19-CB-075	CHASSIS, 5130805821, Water Tank Left Mounting Bracket
CV-SSB-19-CB-076	CHASSIS, 5130805822, Electric Car Suction Radiator
CV-SSB-19-CB-077	CHASSIS, 5130805823, Cooling Bag Diagonal Stay Bracket
CV-SSB-19-CB-078	CHASSIS, 5130805824, Water Pump Inlet Pipe
CV-SSB-19-CB-079	CHASSIS, 5130805837, Cooling Bag Diagonal Stay Bracket 2
CV-SSB-19-CB-080	CHASSIS, 5130805838, Water Tank Right Mounting Bracket
CV-SSB-19-CB-081	CHASSIS, 5130805840, Connecting Hose
CV-SSB-19-CB-082	CHASSIS, 5130805843, Water Tank Ventilation Filter
CV-SSB-19-CB-083	CHASSIS, 5130806456, Water Pump Outlet Pipe 1
CV-SSB-19-CB-084	CHASSIS, 5130806460, Motor Controller Inlet Pipe 1
CV-SSB-19-CB-085	CHASSIS, 5130806461, Motor Controller Outlet Pipe 2
CV-SSB-19-CB-086	CHASSIS, 5130806462, Water Tank Inlet Pipe
CV-SSB-19-CB-087	CHASSIS, 5130807214, Motor Water Inlet Pipe
CV-SSB-19-CB-088	CHASSIS, 5130807215, Motor Controller Inlet Pipe 2

CV-SSB-19-CB-089	CHASSIS, 5130807216, Motor Water Pipe
CV-SSB-19-CB-091	CHASSIS, 5220000488, Rear Axle Drive Shaft
CV-SSB-19-CB-092	CHASSIS, 5280002207, Spare Tire Crank
CV-SSB-19-CB-093	CHASSIS, 5280005148, Air Pump Transition Bracket
CV-SSB-19-CB-094	CHASSIS, 5280005198, Electronically Controlled Transition Bracket
CV-SSB-19-CB-095	CHASSIS, 5290002388, Front Air Suspension
CV-SSB-19-CB-096	CHASSIS, 5340000144, Air Reservoir Assembly
CV-SSB-19-CB-097	CHASSIS, 5340000172, Oil Return Over Joint
CV-SSB-19-CB-098	CHASSIS, 5340000575, Steering Drive Shaft
CV-SSB-19-CB-099	CHASSIS, 5340001042, Steering Arm
CV-SSB-19-CB-100	CHASSIS, 5340001070, Steering Column and Drive Shaft
CV-SSB-19-CB-101	CHASSIS, 5340001203, Steering Straight Rod Assembly
CV-SSB-19-CB-102	CHASSIS, 5350000647, Flexible Metal Hose
CV-SSB-19-CB-103	CHASSIS, 5350002577, Aluminum Alloy Air Reservoir Assembly (With Two Straps)
CV-SSB-19-CB-105	CHASSIS, 5370004143, Instrument Wiring Harness
CV-SSB-19-CB-106	CHASSIS, 5370004145, Power Motor Line
CV-SSB-19-CB-107	CHASSIS, 5370004147, Power Control Harness
CV-SSB-19-CB-108	CHASSIS, 5370004148, Bus Instrument
CV-SSB-19-CB-109	CHASSIS, 5370004149, Combination Rocker Switch
CV-SSB-19-CB-110	CHASSIS, 5370004150, Power Main Switch Assembly
CV-SSB-19-CB-111	CHASSIS, 5400109719, ABS Harness
CV-SSB-19-CB-112	STEERING, Electric Hydraulic Power Steering Pump, 20 Seconds Low Voltage Backup
CV-SSB-19-CB-113	AIR PUMP, Electric Air Compressor
CV-SSB-19-CB-114	STEERING, Tilt/ Telescope Steering Wheel
CV-SSB-19-CB-115	HORN, Air Horn & Electric Horn
CV-SSB-19-CB-116	BATTERY, (2) 12-Volt Group 95R battery
CV-SSB-19-CB-117	BATTERY BOX, Steel with Sliding Tray for Standard Group 95R Battery, Mounted Left Side Rear Axle
CV-SSB-19-CB-118	CHASSIS COATING, Electrophoresis Technology Coating Full Chassis
CV-SSB-19-CB-119	MOTOR, DANA TM4 permanent magnet synchronous motor with cooling system, with retarder function. Base Horse Power: 469horse power(350kW) max. 261.5 horse power(196kW) max 30 min.
CV-SSB-19-CB-120	MOTOR, Motor Controller Unit CO200
CV-SSB-19-CB-121	AXLE, REAR, Rear Disc Brake Axle, Rated Loading 28,660lbs with Disc Brake
CV-SSB-19-CB-122	SUSPENSION, REAR, Air Suspension
CV-SSB-19-CB-123	GAUGE
CV-SSB-19-CB-124	WHEELS, Aluminum alloy rim, Dual bright with spare tire and rim
CV-SSB-19-CB-125	WHEELS, 12R 22.5 Tires on 22.5 Wheels, DOT Approved
CV-SSB-19-CB-126	BODY, Monocoque Body Structure
CV-SSB-19-CB-127	LINING, Light grey interior paint
CV-SSB-19-CB-128	WINDSHIELD, 2 Piece Windshield

CV-SSB-19-CB-129	WINDOW, Windows Split Sash with 12" Egress
CV-SSB-19-CB-130	WINDOW, Windows Split Sash with 12" Egress, with Push Out Emergency Exit
CV-SSB-19-CB-131	STEP, Studded Steps, White Nosing with Black Treads
CV-SSB-19-CB-132	FLOOR, Dark Gray Composite Flooring
CV-SSB-19-CB-133	ROOF, White Roof with Roof Lettering
CV-SSB-19-CB-134	LIGHTS, INTERIOR, LED Light Stripe Integrated into Air Duct
CV-SSB-19-CB-135	LIGHTS, INTERIOR, LED Driver Dom Light
CV-SSB-19-CB-136	RUB RAILS, Rub Rails Painted Black
CV-SSB-19-CB-137	CHARGER, On-Board Charger and Cable with Plug (~20kW J1772/Level II charger)
CV-SSB-19-CB-138	TOW HOOKS, One Hook Front
CV-SSB-19-CB-139	DOOR, Rear Emergency Door 35"
CV-SSB-19-CB-140	DOOR, RED, Lock Assy, Door, Single Point Tapered Rh
CV-SSB-19-CB-141	DOOR, RED, Handle I/S Wide Red Painted
CV-SSB-19-CB-142	DOOR, RED, Black Bar 6"Wide 1/2" Thick 1 Ft Long
CV-SSB-19-CB-143	DOOR, RED, Steel Pull Handle
CV-SSB-19-CB-144	DOOR, RED, Door Switch
CV-SSB-19-CB-145	DOOR, Left Side Emergency Door 28" (LSED) w/ Telescopic Retainer, Floor Level Entry, Title 13 Required
CV-SSB-19-CB-146	DOOR, LSED, Handle, Door, O/S, Rear Emergency, Black D3Fe
CV-SSB-19-CB-147	DOOR, LSED, Telescopic Sed Lock Support
CV-SSB-19-CB-148	DOOR, LSED, Handle Inside Rear Emergency D
CV-SSB-19-CB-149	DOOR, LSED, Lock Assy Door Single Point Ta
CV-SSB-19-CB-150	DOOR, LSED, Steel Pull Handle
CV-SSB-19-CB-151	DOOR, LSED, Door Switch
CV-SSB-19-CB-152	SEATS, Air Driver's Seat
CV-SSB-19-CB-153	SEATS, CA Legal School Bus Bench Seats for 90 Pax
CV-SSB-19-CB-154	FAN, 6" Drivers Fan
CV-SSB-19-CB-155	ROOF HATCH, FRONT and REAR, Transpec Triple Value Roof Vents
CV-SSB-19-CB-156	HVAC, CoolTek Electric Ducted HVAC System
CV-SSB-19-CB-157	HEATER, Driver Windshield Defroster
CV-SSB-19-CB-158	MIRROR, INSIDE 10" x 30" with Roscoe STSK1030 Mirror Camera System
CV-SSB-19-CB-159	MIRROR, CROSSVIEW, EXTERIOR Black
CV-SSB-19-CB-160	MIRROR, REAR, Roscoe BSSK1001 Back-up Warning System
CV-SSB-19-CB-161	MIRROR, REAR, EXTERIOR, Heated Motorized Head, Black, Remote Control from Driver Area
CV-SSB-19-CB-162	ALARM, Child Checkmate Wiring, 12 Volt (only wiring front to rear)
CV-SSB-19-CB-163	ALARM, Child Check Unit
CV-SSB-19-CB-164	SUN VISOR, Driver's Front and Side Sun Visor
CV-SSB-19-CB-165	DRAIN, Driver Dash Located Electric Air Drains
CV-SSB-19-CB-166	RADIO, Radio with PA, with Six Speakers
CV-SSB-19-CB-167	KIT, FIRST AID 24 Unit, California
CV-SSB-19-CB-168	CERTIFICATE HOLDER for State of California

CV-SSB-19-CB-169	SWITCH, Noise Suppression Switch (Turns Off HVAC, Defroster, Dash Fan, Radio)
CV-SSB-19-CB-170	STOP ARM, LEFT Front Electric, Composite Blade, 18" Octagon, Double Sided
CV-SSB-19-CB-171	ALARM, Backup Alarm
CV-SSB-19-CB-172	DECAL, Red Reflector/Spitfire-Rr-4.435In X 1.640 In
CV-SSB-19-CB-173	DECAL, Yellow Reflector / Tape
CV-SSB-19-CB-174	DECAL, To Open Lift Red Bar
CV-SSB-19-CB-175	DECAL, Watch Your Step
CV-SSB-19-CB-176	DECAL, Battery Cut Off
CV-SSB-19-CB-177	DECAL, Air Drain Decal
CV-SSB-19-CB-178	DECAL, M17 - Fasten Seat Belts 1.5" X 4" Red on White
CV-SSB-19-CB-179	DECAL, Fire Extinguisher
CV-SSB-19-CB-180	DECAL, Emergency Exit Lift Handle Push Out to Open
CV-SSB-19-CB-181	DECAL, Exit with Arrows
CV-SSB-19-CB-182	DECAL, First Aid Kit
CV-SSB-19-CB-183	DECAL, This Vehicle Stops at All Railroad Crossings
CV-SSB-19-CB-184	DECAL, Arrow Clockwise
CV-SSB-19-CB-185	DECAL, Arrow Counter clock Wise
CV-SSB-19-CB-186	DECAL, Exterior Emergency Exit
CV-SSB-19-CB-187	DECAL, Stop When Red Lights Flash
CV-SSB-19-CB-188	DECAL, School Bus
CV-SSB-19-CB-189	DECAL, Lift to Open
CV-SSB-19-CB-190	DECAL, Emergency Exit
CV-SSB-19-CB-191	DECAL, Decal, Watch Your Step, Black on White, 2.5" X 12.5"
CV-SSB-19-CB-192	DECAL, Operates from Inside Only, Face Adhesive on White
CV-SSB-19-CB-193	LIGHTS, Red School Bus Warning Lamp
CV-SSB-19-CB-194	LIGHTS, Amber School Bus Warning Lamp
CV-SSB-19-CB-195	LIGHTS, Front Amber Turn Signal
CV-SSB-19-CB-196	LIGHTS, Amber Marker Lights
CV-SSB-19-CB-197	LIGHTS, Red Marker Lights
CV-SSB-19-CB-198	LIGHTS, Rear Amber Turn Signal
CV-SSB-19-CB-199	LIGHTS, Rear Tail and Stop Lamp
CV-SSB-19-CB-200	LIGHTS, Stop Light
CV-SSB-19-CB-201	LIGHTS, Backup Light
CV-SSB-19-CB-202	LIGHTS, Curb Door Light
CV-SSB-19-CB-203	LIGHTS, Above Wheel Lamp Led, Length 5-7/8", Width 2", Depth 1-1/2", Color Yellow
CV-SSB-19-CB-204	LIGHTS, Warning Light Visor
CV-SSB-19-CB-205	LIGHTS, Amber Reflex Reflector
CV-SSB-19-CB-206	LIGHTS, Red Reflex Reflector
CV-SSB-19-CB-207	LIGHTS, 7" Led Headlamp H/L
CV-SSB-19-CB-208	LIGHTS, Strobe, Peterson 14 Joule Duple Flahs School Bus Beacon - 792C
CV-SSB-19-CB-209	LIGHTS, Stepwell Light

CV-SSB-19-CB-210
CV-SSB-19-CB-211

MUD FLAPS, Front & Rear Wheels (4) Rubber
FIRE EXTINGUISHER, DRIVER AREA 5 lb. 2A-40BC Minimum with Flexible
Hose and Metal Nozzle, Mounted

Date: 3/10/23
Quote Valid Until:
Prepared By: TOM HARTMAN



Name:
Organization: EQUALIS GROUP
Address:
City, State ZIP:
Phone:

YEAR:	2024
MAKE:	Greenpower
MODEL:	BEAST
CAPACITY:	90
STOCK #'S:	RWCGPBEAST-2

		INCLUDES 3 CAMERA SYSTEM AND DVR INCLUDES AC SYSTEM EV FREEBLOW	\$ 560,000.00
TRADE BUS #:		Trade Total:	\$ -
		Pre Tax Sub Total:	\$ 560,000.00
		Sales Tax ():	\$ -
		Local Delivery Charge: 0	\$ -
		\$ -	-
TOTAL PRICE:			\$ 560,000.00

DWCGP BEAST-2 EV 194 kW 90 passenger

Model Profile

2023 GreenPower BEAST School Bus 90

APPLICATION: School Transportation

DIMENSION: Wheelbase: 240"

Electric Motor: DANA TM4 permanent magnet synchronous motor with cooling system, with retarder function.
Base Horse Power: 469horse power(350kW) max. 261.5 horse power(196kW) max 30 min.

BATTERY: 614.4V/315AH, 193.5kWh with 6 packs, Lithium iron phosphate battery with Battery Management System (BMS), and Battery Thermal Management System (TMS)

CHARGE: CCS-1 DC Fast Charger (up to 50 kW), CCS-1 AC Level 2 (up to 19.2 kW)

AXLE, FRONT NON-DRIVING: Front disc brake axle, rated loading 14330-lb with disc brake

AXLE, REAR: Rear disc brake axle, rated loading 28,660-lb with disc brake

TIRE, FRONT: (2) 12R22.5 tubeless radial tire

TIRE, REAR: (4) 12R22.5 tubeless radial tire

RIM: {Alcoa} Aluminum alloy rim, Dual bright with spare tire and rim

SUSPENSION, REAR, AIR: Firestone air bags, shock absorber

BRAKE: Service brake: Knorr Pneumatic Disc dual circuit full air brake, Parking brake: storage energy spring braking, acting on rear axle. WABCO brand of all components for braking system

PAINT: AXALTA N5898 EF School bus yellow

Vehicle Specifications
2023 GreenPower School Bus 90

Code	Description
CV-SSB-19-CB-001	Base Chassis, Wheelbase: 240"
CV-SSB-19-CB-002	BUMPER, Chassis Integrated Bumpers
CV-SSB-19-CB-003A	BATTERY, 614.4V/315AH, 193.5kWh with 6 packs, Lithium iron phosphate battery with Battery Management System (BMS)
CV-SSB-19-CB-004	AXLE, FRONT NON-DRIVING: Front Disc Brake Axle, Rated Loading 14330-lb with Disc Brake
CV-SSB-19-CB-005	SUSPENSION, FRONT, Air Suspension
CV-SSB-19-CB-006	BRAKE, Service Brake: Pneumatic Dual Circuit Full Air Brake, Parking brake: Storage Energy Spring Braking, Acting on Rear Axle. WABCO Brand of All Components for Braking System
CV-SSB-19-CB-007	BRAKE, Pneumatic Disc Brakes, Front and Rear Axles, with ABS
CV-SSB-19-CB-008	BRAKE, Regenerative Braking
CV-SSB-19-CB-009	Manual Air Drains for All Five Air Tanks- Full Drain for Brake Check
CV-SSB-19-CB-010	Dual Air Gauges for Performing Required Daily CHP Full Drain Air Brake Test
CV-SSB-19-CB-011	5-IN-1 UNIT, Control Unit, DC/AC Convertor, High Voltage Distribution System
CV-SSB-19-CB-012	CHASSIS, 1130300226, Water Hose (Without Insulation Pipe)
CV-SSB-19-CB-013	CHASSIS, 1290100003, Rubber Cushion
CV-SSB-19-CB-014	CHASSIS, 1340600300, Steering Oil Inlet Pipe Assembly
CV-SSB-19-CB-015	CHASSIS, 1340600321, Steering Return Pipe Assembly
CV-SSB-19-CB-016	CHASSIS, 1930460010, Acceleration/Brake Pedal Pad
CV-SSB-19-CB-017	CHASSIS, 2110800347, Electronic Accelerator Pedal
CV-SSB-19-CB-018	CHASSIS, 2130200004, Support Cushion on The Water Tank
CV-SSB-19-CB-019	CHASSIS, 2130700008, Water Pump (Drive Motor Cooling)
CV-SSB-19-CB-020	CHASSIS, 2131100026, Plastic Expansion Tank for Electric Vehicles
CV-SSB-19-CB-021	CHASSIS, 2131300052, Electronic Fan
CV-SSB-19-CB-023	CHASSIS, 2290100006, Vibration Proof Rubber Mat
CV-SSB-19-CB-024	CHASSIS, 2310200122, Front Wheel Sleeve Nut
CV-SSB-19-CB-025	CHASSIS, 2310200123, Rear Wheel Sleeve Nut
CV-SSB-19-CB-026	CHASSIS, 2310500006, Chassis Spare Tire Lifter
CV-SSB-19-CB-027	CHASSIS, 2340810023, Power Steering Oil Tank Assembly
CV-SSB-19-CB-028	CHASSIS, 2341500005, Angular Actuator
CV-SSB-19-CB-029	CHASSIS, 2350000007, Silencer - Wabco
CV-SSB-19-CB-030	CHASSIS, 2350500016, Brake Master Cylinder
CV-SSB-19-CB-031	CHASSIS, 2351400005, Pressure Limiting Valve
CV-SSB-19-CB-032	CHASSIS, 2351800009, Relay Valve
CV-SSB-19-CB-033	CHASSIS, 2351800014, Differential Relay Valve
CV-SSB-19-CB-034	CHASSIS, 2352000001, Pneumatic Signal Light Switch
CV-SSB-19-CB-035	CHASSIS, 2352600011, Manual Valve
CV-SSB-19-CB-036	CHASSIS, 2355000019, Wabco ABS

CV-SSB-19-CB-037	CHASSIS, 2355500031, Condenser
CV-SSB-19-CB-038	CHASSIS, 2355500057, Air Dryer
CV-SSB-19-CB-039	CHASSIS, 2356100104, Brake Hose
CV-SSB-19-CB-041	CHASSIS, 2357300014, Four Circuit Protection Valve
CV-SSB-19-CB-042	CHASSIS, 2360000083, Electronic Gear Switch
CV-SSB-19-CB-043	CHASSIS, 2370000701, 4kW Air Compressor
CV-SSB-19-CB-044	CHASSIS, 2370000734, Double Source Electric Pump
CV-SSB-19-CB-045	CHASSIS, 2370000736, 24V Controller
CV-SSB-19-CB-046	CHASSIS, 2371100192, Electrical Control Box
CV-SSB-19-CB-047	CHASSIS, 2372101010, Electric Horn
CV-SSB-19-CB-048	CHASSIS, 2373500003, Ordinary Relay (24V/5 Foot 2914)
CV-SSB-19-CB-049	CHASSIS, 2373510003, Wiper Relay
CV-SSB-19-CB-050	CHASSIS, 2373610084, Manual Power Main Switch A (Left Exit)
CV-SSB-19-CB-051	CHASSIS, 2379900004, Brake Switch
CV-SSB-19-CB-052	CHASSIS, 2381900018, Reversing Buzzer (Amp Plug-In 282044-1 (M)) - Yx
CV-SSB-19-CB-053	CHASSIS, 2387500018, Air Pressure Sensor (Small Housing Stainless Steel)
CV-SSB-19-CB-054	CHASSIS, 2391000200, Automatic Fire Extinguisher 3/Set (With Manual Push Button Switch, Start Feedback Device)
CV-SSB-19-CB-055	CHASSIS, 2406200001, Copper Preparation Line
CV-SSB-19-CB-062	CHASSIS, 2425000012, Centralized Lubrication
CV-SSB-19-CB-063	CHASSIS, 2810126004, Water Hose
CV-SSB-19-CB-064	CHASSIS, 2810142359, Water Hose
CV-SSB-19-CB-065	CHASSIS, 3050300004, Oil Resistant Hose*
CV-SSB-19-CB-068	CHASSIS, 5100002805, Front Suspension Left Bracket
CV-SSB-19-CB-069	CHASSIS, 5100002806, Front Suspension Right Bracket
CV-SSB-19-CB-070	CHASSIS, 5120000099, Gasket
CV-SSB-19-CB-071	CHASSIS, 5130800203, Upper Gasket
CV-SSB-19-CB-072	CHASSIS, 5130801596, Water Tank Support Rod
CV-SSB-19-CB-073	CHASSIS, 5130803494, Electrician Bracket
CV-SSB-19-CB-074	CHASSIS, 5130805750, Water Pump Inlet Joint
CV-SSB-19-CB-075	CHASSIS, 5130805821, Water Tank Left Mounting Bracket
CV-SSB-19-CB-076	CHASSIS, 5130805822, Electric Car Suction Radiator
CV-SSB-19-CB-077	CHASSIS, 5130805823, Cooling Bag Diagonal Stay Bracket
CV-SSB-19-CB-078	CHASSIS, 5130805824, Water Pump Inlet Pipe
CV-SSB-19-CB-079	CHASSIS, 5130805837, Cooling Bag Diagonal Stay Bracket 2
CV-SSB-19-CB-080	CHASSIS, 5130805838, Water Tank Right Mounting Bracket
CV-SSB-19-CB-081	CHASSIS, 5130805840, Connecting Hose
CV-SSB-19-CB-082	CHASSIS, 5130805843, Water Tank Ventilation Filter
CV-SSB-19-CB-083	CHASSIS, 5130806456, Water Pump Outlet Pipe 1
CV-SSB-19-CB-084	CHASSIS, 5130806460, Motor Controller Inlet Pipe 1
CV-SSB-19-CB-085	CHASSIS, 5130806461, Motor Controller Outlet Pipe 2
CV-SSB-19-CB-086	CHASSIS, 5130806462, Water Tank Inlet Pipe
CV-SSB-19-CB-087	CHASSIS, 5130807214, Motor Water Inlet Pipe
CV-SSB-19-CB-088	CHASSIS, 5130807215, Motor Controller Inlet Pipe 2

CV-SSB-19-CB-089	CHASSIS, 5130807216, Motor Water Pipe
CV-SSB-19-CB-091	CHASSIS, 5220000488, Rear Axle Drive Shaft
CV-SSB-19-CB-092	CHASSIS, 5280002207, Spare Tire Crank
CV-SSB-19-CB-093	CHASSIS, 5280005148, Air Pump Transition Bracket
CV-SSB-19-CB-094	CHASSIS, 5280005198, Electronically Controlled Transition Bracket
CV-SSB-19-CB-095	CHASSIS, 5290002388, Front Air Suspension
CV-SSB-19-CB-096	CHASSIS, 5340000144, Air Reservoir Assembly
CV-SSB-19-CB-097	CHASSIS, 5340000172, Oil Return Over Joint
CV-SSB-19-CB-098	CHASSIS, 5340000575, Steering Drive Shaft
CV-SSB-19-CB-099	CHASSIS, 5340001042, Steering Arm
CV-SSB-19-CB-100	CHASSIS, 5340001070, Steering Column and Drive Shaft
CV-SSB-19-CB-101	CHASSIS, 5340001203, Steering Straight Rod Assembly
CV-SSB-19-CB-102	CHASSIS, 5350000647, Flexible Metal Hose
CV-SSB-19-CB-103	CHASSIS, 5350002577, Aluminum Alloy Air Reservoir Assembly (With Two Straps)
CV-SSB-19-CB-105	CHASSIS, 5370004143, Instrument Wiring Harness
CV-SSB-19-CB-106	CHASSIS, 5370004145, Power Motor Line
CV-SSB-19-CB-107	CHASSIS, 5370004147, Power Control Harness
CV-SSB-19-CB-108	CHASSIS, 5370004148, Bus Instrument
CV-SSB-19-CB-109	CHASSIS, 5370004149, Combination Rocker Switch
CV-SSB-19-CB-110	CHASSIS, 5370004150, Power Main Switch Assembly
CV-SSB-19-CB-111	CHASSIS, 5400109719, ABS Harness
CV-SSB-19-CB-112	STEERING, Electric Hydraulic Power Steering Pump, 20 Seconds Low Voltage Backup
CV-SSB-19-CB-113	AIR PUMP, Electric Air Compressor
CV-SSB-19-CB-114	STEERING, Tilt/ Telescope Steering Wheel
CV-SSB-19-CB-115	HORN, Air Horn & Electric Horn
CV-SSB-19-CB-116	BATTERY, (2) 12-Volt Group 95R battery
CV-SSB-19-CB-117	BATTERY BOX, Steel with Sliding Tray for Standard Group 95R Battery, Mounted Left Side Rear Axle
CV-SSB-19-CB-118	CHASSIS COATING, Electrophoresis Technology Coating Full Chassis
CV-SSB-19-CB-119	MOTOR, DANA TM4 permanent magnet synchronous motor with cooling system, with retarder function. Base Horse Power: 469horse power(350kW) max. 261.5 horse power(196kW) max 30 min.
CV-SSB-19-CB-120	MOTOR, Motor Controller Unit CO200
CV-SSB-19-CB-121	AXLE, REAR, Rear Disc Brake Axle, Rated Loading 28,660lbs with Disc Brake
CV-SSB-19-CB-122	SUSPENSION, REAR, Air Suspension
CV-SSB-19-CB-123	GAUGE
CV-SSB-19-CB-124	WHEELS, Aluminum alloy rim, Dual bright with spare tire and rim
CV-SSB-19-CB-125	WHEELS, 12R 22.5 Tires on 22.5 Wheels, DOT Approved
CV-SSB-19-CB-126	BODY, Monocoque Body Structure
CV-SSB-19-CB-127	LINING, Light grey interior paint
CV-SSB-19-CB-128	WINDSHIELD, 2 Piece Windshield

CV-SSB-19-CB-129	WINDOW, Windows Split Sash with 12" Egress
CV-SSB-19-CB-130	WINDOW, Windows Split Sash with 12" Egress, with Push Out Emergency Exit
CV-SSB-19-CB-131	STEP, Studded Steps, White Nosing with Black Treads
CV-SSB-19-CB-132	FLOOR, Dark Gray Composite Flooring
CV-SSB-19-CB-133	ROOF, White Roof with Roof Lettering
CV-SSB-19-CB-134	LIGHTS, INTERIOR, LED Light Stripe Integrated into Air Duct
CV-SSB-19-CB-135	LIGHTS, INTERIOR, LED Driver Dom Light
CV-SSB-19-CB-136	RUB RAILS, Rub Rails Painted Black
CV-SSB-19-CB-137	CHARGER, On-Board Charger and Cable with Plug (~20kW J1772/Level II charger)
CV-SSB-19-CB-138	TOW HOOKS, One Hook Front
CV-SSB-19-CB-139	DOOR, Rear Emergency Door 35"
CV-SSB-19-CB-140	DOOR, RED, Lock Assy, Door, Single Point Tapered Rh
CV-SSB-19-CB-141	DOOR, RED, Handle I/S Wide Red Painted
CV-SSB-19-CB-142	DOOR, RED, Black Bar 6"Wide 1/2" Thick 1 Ft Long
CV-SSB-19-CB-143	DOOR, RED, Steel Pull Handle
CV-SSB-19-CB-144	DOOR, RED, Door Switch
CV-SSB-19-CB-145	DOOR, Left Side Emergency Door 28" (LSED) w/ Telescopic Retainer, Floor Level Entry, Title 13 Required
CV-SSB-19-CB-146	DOOR, LSED, Handle, Door, O/S, Rear Emergency, Black D3Fe
CV-SSB-19-CB-147	DOOR, LSED, Telescopic Sed Lock Support
CV-SSB-19-CB-148	DOOR, LSED, Handle Inside Rear Emergency D
CV-SSB-19-CB-149	DOOR, LSED, Lock Assy Door Single Point Ta
CV-SSB-19-CB-150	DOOR, LSED, Steel Pull Handle
CV-SSB-19-CB-151	DOOR, LSED, Door Switch
CV-SSB-19-CB-152	SEATS, Air Driver's Seat
CV-SSB-19-CB-153	SEATS, CA Legal School Bus Bench Seats for 90 Pax
CV-SSB-19-CB-154	FAN, 6" Drivers Fan
CV-SSB-19-CB-155	ROOF HATCH, FRONT and REAR, Transpec Triple Value Roof Vents
CV-SSB-19-CB-156	HVAC, CoolTek Electric Ducted HVAC System
CV-SSB-19-CB-157	HEATER, Driver Windshield Defroster
CV-SSB-19-CB-158	MIRROR, INSIDE 10" x 30" with Roscoe STSK1030 Mirror Camera System
CV-SSB-19-CB-159	MIRROR, CROSSVIEW, EXTERIOR Black
CV-SSB-19-CB-160	MIRROR, REAR, Roscoe BSSK1001 Back-up Warning System
CV-SSB-19-CB-161	MIRROR, REAR, EXTERIOR, Heated Motorized Head, Black, Remote Control from Driver Area
CV-SSB-19-CB-162	ALARM, Child Checkmate Wiring, 12 Volt (only wiring front to rear)
CV-SSB-19-CB-163	ALARM, Child Check Unit
CV-SSB-19-CB-164	SUN VISOR, Driver's Front and Side Sun Visor
CV-SSB-19-CB-165	DRAIN, Driver Dash Located Electric Air Drains
CV-SSB-19-CB-166	RADIO, Radio with PA, with Six Speakers
CV-SSB-19-CB-167	KIT, FIRST AID 24 Unit, California
CV-SSB-19-CB-168	CERTIFICATE HOLDER for State of California

CV-SSB-19-CB-169	SWITCH, Noise Suppression Switch (Turns Off HVAC, Defroster, Dash Fan, Radio)
CV-SSB-19-CB-170	STOP ARM, LEFT Front Electric, Composite Blade, 18" Octagon, Double Sided
CV-SSB-19-CB-171	ALARM, Backup Alarm
CV-SSB-19-CB-172	DECAL, Red Reflector/Spitfire-Rr-4.435In X 1.640 In
CV-SSB-19-CB-173	DECAL, Yellow Reflector / Tape
CV-SSB-19-CB-174	DECAL, To Open Lift Red Bar
CV-SSB-19-CB-175	DECAL, Watch Your Step
CV-SSB-19-CB-176	DECAL, Battery Cut Off
CV-SSB-19-CB-177	DECAL, Air Drain Decal
CV-SSB-19-CB-178	DECAL, M17 - Fasten Seat Belts 1.5" X 4" Red on White
CV-SSB-19-CB-179	DECAL, Fire Extinguisher
CV-SSB-19-CB-180	DECAL, Emergency Exit Lift Handle Push Out to Open
CV-SSB-19-CB-181	DECAL, Exit with Arrows
CV-SSB-19-CB-182	DECAL, First Aid Kit
CV-SSB-19-CB-183	DECAL, This Vehicle Stops at All Railroad Crossings
CV-SSB-19-CB-184	DECAL, Arrow Clockwise
CV-SSB-19-CB-185	DECAL, Arrow Counter clock Wise
CV-SSB-19-CB-186	DECAL, Exterior Emergency Exit
CV-SSB-19-CB-187	DECAL, Stop When Red Lights Flash
CV-SSB-19-CB-188	DECAL, School Bus
CV-SSB-19-CB-189	DECAL, Lift to Open
CV-SSB-19-CB-190	DECAL, Emergency Exit
CV-SSB-19-CB-191	DECAL, Decal, Watch Your Step, Black on White, 2.5" X 12.5"
CV-SSB-19-CB-192	DECAL, Operates from Inside Only, Face Adhesive on White
CV-SSB-19-CB-193	LIGHTS, Red School Bus Warning Lamp
CV-SSB-19-CB-194	LIGHTS, Amber School Bus Warning Lamp
CV-SSB-19-CB-195	LIGHTS, Front Amber Turn Signal
CV-SSB-19-CB-196	LIGHTS, Amber Marker Lights
CV-SSB-19-CB-197	LIGHTS, Red Marker Lights
CV-SSB-19-CB-198	LIGHTS, Rear Amber Turn Signal
CV-SSB-19-CB-199	LIGHTS, Rear Tail and Stop Lamp
CV-SSB-19-CB-200	LIGHTS, Stop Light
CV-SSB-19-CB-201	LIGHTS, Backup Light
CV-SSB-19-CB-202	LIGHTS, Curb Door Light
CV-SSB-19-CB-203	LIGHTS, Above Wheel Lamp Led, Length 5-7/8", Width 2", Depth 1-1/2", Color Yellow
CV-SSB-19-CB-204	LIGHTS, Warning Light Visor
CV-SSB-19-CB-205	LIGHTS, Amber Reflex Reflector
CV-SSB-19-CB-206	LIGHTS, Red Reflex Reflector
CV-SSB-19-CB-207	LIGHTS, 7" Led Headlamp H/L
CV-SSB-19-CB-208	LIGHTS, Strobe, Peterson 14 Joule Duple Flahs School Bus Beacon - 792C
CV-SSB-19-CB-209	LIGHTS, Stepwell Light

CV-SSB-19-CB-210
CV-SSB-19-CB-211

MUD FLAPS, Front & Rear Wheels (4) Rubber
FIRE EXTINGUISHER, DRIVER AREA 5 lb. 2A-40BC Minimum with Flexible
Hose and Metal Nozzle, Mounted

Date: 3/10/23
 Quote Valid Until:
 Prepared By: TOM HARTMAN



Name:
 Organization: EQUALIS GROUP
 Address:
 City, State ZIP:
 Phone:

YEAR:	2024
MAKE:	Greenpower
MODEL:	NANO BEAST
CAPACITY:	24
STOCK #'S:	RWCGPBEST-3

		\$ 425,000.00
INCLUDES 3 CAMERA SYSTEM AND DVR INCLUDES AC SYSTEM EV FREEBLOW		
TRADE BUS #:		Trade Total:
		\$ -
Pre Tax Sub Total:		\$ 425,000.00
Sales Tax ():		\$ -
Local Delivery Charge: 0		\$ -
		\$ -
TOTAL PRICE:		\$ 425,000.00



Date: 3/10/23
Quote Valid Until:
Prepared By: TOM HARTMAN

Name:
Organization: EQUALIS GROUP
Address:
City, State ZIP:
Phone:

YEAR:	2024
MAKE:	Greenpower
MODEL:	NANO BEAST
CAPACITY:	18 PLUS 1 WC
STOCK #'S:	RWCGPBEST-4

INCLUDES 3 CAMERA SYSTEM AND DVR INCLUDES AC SYSTEM EV FREEBLOW		\$ 430,000.00
TRADE BUS #:		Trade Total: \$ -
Pre Tax Sub Total:		\$ 430,000.00
Sales Tax ():		\$ -
Local Delivery Charge: 0		\$ -
		\$ -
TOTAL PRICE:		\$ 430,000.00

Date: 3/10/23
Quote Valid Until:
Prepared By: TOM HARTMAN



Name:
Organization: EQUALIS GROUP
Address:
City, State ZIP:
Phone:

YEAR:	2024
MAKE:	IC
MODEL:	CE EV
CAPACITY:	60-71
STOCK #'S:	RWCICCE-1

INCLUDES 3 CAMERA SYSTEM AND DVR INCLUDES AC SYSTEM EV FREEBLOW		\$ 525,000.00
<div style="text-align: center; opacity: 0.5; font-size: 2em;"> </div>		
TRADE BUS #:		Trade Total: \$ -
Pre Tax Sub Total:		\$ 525,000.00
Sales Tax ():		\$ -
Local Delivery Charge: 0		\$ -
TOTAL PRICE:		\$ 525,000.00

June 16, 2022

RWC ICCE-1 EV Bus 60-71 Pass

Prepared For:
RWC INTERNATIONAL, LTD
TOM HARTMAN
2202 S Central Ave.
Phoenix, AZ 85004-2908
(602)307 - 1050
Reference ID: 3402-276-66E3S

Presented By:
RWC Group
Julie Shockley
600 North 75th Avenue
PHOENIX AZ 85043 -
(602)307-1050

Model Profile
2023 Electric CE S Bus (PB10E)

APPLICATION:	School Transportation
MISSION:	Requested GVWR: 33000. Calc. GVWR: 33000 Calc. Start / Grade Ability: 0.00% / 0.00% @ 0 MPH Calc. Geared Speed: N/A
DIMENSION:	Wheelbase: 276.00, CA: N/A, Axle to Frame: 157.00
MOTOR, ELECTRIC, DRIVETRAIN:	{Dana TM4 SUMO MD HV2200-6P} 255kW Rated Power @ 1000 RPM, 2355 Nm Rated Torque @ 1000 RPM
AXLE, FRONT NON-DRIVING:	{Meritor MFS-10-122A} I-Beam Type, 10,000-lb Capacity
AXLE, REAR, SINGLE:	{Dana Spicer S23-172F} Single Reduction, Pinion Up, 23,000-lb Capacity, R Wheel Ends Gear Ratio: 6.83
TIRE, FRONT:	(2) 11R22.5 Load Range H ECOPLUS HS3+ (CONTINENTAL), 495 rev/mile, 75 MPH, All-Position
TIRE, REAR:	(4) 11R22.5 Load Range H ECOPLUS HS3+ (CONTINENTAL), 495 rev/mile, 75 MPH, All-Position
SUSPENSION, REAR, AIR, SINGLE:	{International IROS} 23,000-lb Capacity, 9.25" Ride Height, with Shock Absorbers
PAINT:	Cab schematic 101NB Location 1: 4421, School Bus Yellow (Std) Location 2: 4422, School Bus Yellow Non Reflective (Nrf) Chassis schematic N/A

Vehicle Specifications
2023 Electric CE S Bus (PB10E)

June 16, 2022

Code	Description
PB10E00	Base Chassis, Model Electric CE S Bus with 276.00 Wheelbase, N/A CA, and 157.00 Axle to Frame.
1570	TOW HOOK, FRONT (2) Frame Mounted
1CGL	FRAME RAILS Heat Treated Alloy Steel (120,000 PSI Yield); 10.125" x 3.062" x 0.312" (257.2mm x 77.8mm x 8.0mm); 480.1" (12195mm) Maximum OAL
1LLE	BUMPER, FRONT Contoured, Steel, Severe Duty
1LNT	CROSSING GATE, FRONT Omit Item
1SAM	CROSSMEMBER, REAR, AF (2)
1WJE	WHEELBASE RANGE 276" (700cm) Only
1WRP	TOW HOOK, REAR (2) Mounted on Lower Rail Flange
2ASH	AXLE, FRONT NON-DRIVING {Meritor MFS-10-122A} I-Beam Type, 10,000-lb Capacity
3ADB	SUSPENSION, FRONT, SPRING Parabolic Taper Leaf, Shackle Type, 10,000-lb Capacity, with Shock Absorbers
4091	BRAKE SYSTEM, AIR Dual System for Straight Truck Applications
4AZS	AIR BRAKE ABS {Bendix AntiLock Brake System} 4-Channel (4 Sensor/4 Modulator) Electronic Stability Program, with Automatic Traction Control
4EBT	AIR DRYER {Bendix AD-IP} with Heater
4SPS	AIR COMPRESSOR {Quanxing} 10.6 CFM, for Electric Vehicle
4VLN	AIR TANK LOCATION (2) Mounted Outside Right Rail, Side by Side, Back of Stepwell, for Electric Vehicle
4WWX	DRAIN VALVE {Humphrey} (3) Air Operated, with Controls in Drivers Compartment, for Air Tanks
4WZT	GVWR LIMITATION FOR BUS with Air Brakes, Limited to 33,000-lbs Maximum to meet FMVSS 121 Requirements, for Conventional Bus
4XCJ	BRAKES, FRONT {Bendix Spicer ADB22X} Air Disc Type, Extended Service, Size 22.5", 23,000-lb Capacity
4XCK	BRAKES, REAR {Bendix Spicer ADB22X} Air Disc Type, Extended Service, Size 22.5", 26,000-lb Capacity per Axle
4XDW	BRAKE CHAMBERS, FRONT AXLE 18 SqIn, for Air Disc Brakes
4XEA	BRAKE CHAMBERS, REAR AXLE 18/24 SqIn Spring Brake, Double Diaphragm, for Air Disc Brakes
5710	STEERING COLUMN Tilting and Telescoping
5CAL	STEERING WHEEL 2-Spoke, 18" Dia., Black
5PRR	STEERING GEAR {TRW (Ross) TAS66} Power
6DGL	DRIVELINE SYSTEM {Dana Spicer} Service Free SPL170, for 4x2/6x2
8000	ELECTRICAL SYSTEM 12-Volt, Standard Equipment
8MVY	BATTERY SYSTEM {Energys Odyssey 31-PC2150 AGM} Maintenance-Free, (2) AGM 12-Volt 2300CCA Total, Top Threaded Stud
8TLD	BATTERY PACK High Voltage, 315 kWh Total Capacity
8TTK	BATTERY BOX Steel, with Sliding Tray, 25.25" Wide, for Standard Batteries, 1-3 Battery Capacity, Mounted Left Side Behind Front Axle Perpendicular to Frame Rail
8VBD	HORN, ELECTRIC (2) Trumpet Style, Mounted Above Right Frame Rail
8WPB	HEADLIGHTS Halogen, Composite Aero Design, with Daytime Running Lights

Vehicle Specifications
2023 Electric CE S Bus (PB10E)

June 16, 2022

<u>Code</u>	<u>Description</u>
8WSU	CHARGING PORT Forward Location, for Electric Vehicle <u>Includes</u> : CHARGING PORT Forward Charging Port Located Right Side Aft of Entrance Door
8WUC	POWER CONVERTER HV Battery to 12V Battery, with Dual Converters, for Electric Vehicle
8WWJ	INDICATOR, LOW COOLANT LEVEL with Audible Alarm
8WXB	HEADLIGHT WARNING BUZZER Sounds When Head Light Switch is on and Ignition Switch is in "Off" Position
8XAH	CIRCUIT BREAKERS Manual-Reset (Main Panel) SAE Type III with Trip Indicators, Replaces All Fuses
8XNX	SOUND GENERATOR for Electric Vehicle
9WAB	HOOD TILT ASSIST {EASY TILT} Mechanical
9WAY	FRONT END Tilting, Fiberglass, with Three Piece Construction
10020	CHASSIS PAINT Full Chassis
10063	PAINT SCHEMATIC, PT-1 Two Tone, Design 101 for Non-Reflecting Schoolbus Hood
10661	PAINT, NON-REFLECTING Non-Reflecting Paint
10788	PAINT TYPE Urethane, One or Two Colors, Other than Imron or International.
10AEP	FLEET HEALTH MONITOR REPORTING for 60 Months
10AET	ADVANCED PREVENTIVE MAINT for 60 Months
10AGC	COMMUNICATIONS MODULE Telematics Device; Includes Five Year Data Plan and International 360
10WHJ	SPECIAL ROUTING CONTROL To Bus Vehicle Modification Center
10WLM	SPECIAL ROUTING CONTROL WIFI to CBC for Kajeet Wi-Fi Installation; Contact CBC for Quote/Pricing
12703	ANTI-FREEZE Red, Extended Life Coolant; To -40 Degrees F/ -40 Degrees C, Freeze Protection
12AAB	MOTOR, ELECTRIC, DRIVETRAIN {Dana TM4 SUMO MD HV2200-6P} 255kW Rated Power @ 1000 RPM, 2355 Nm Rated Torque @ 1000 RPM
12VVN	CRUISE CONTROL Electronic
12VWH	GOVERNOR Electronic Road Speed Type; for Electronic Engines and Bus Models; with 55 MPH Default
12XCJ	RADIATOR Aluminum, 2-Row, Cross Flow, Four 12" E-Fan System, 595 SqIn Louvered, for Electric Vehicle
14ERW	AXLE, REAR, SINGLE {Dana Spicer S23-172F} Single Reduction, Pinion Up, 23,000-lb Capacity, R Wheel Ends . Gear Ratio: 6.83
14TBT	SUSPENSION, REAR, AIR, SINGLE {International IROS} 23,000-lb Capacity, 9.25" Ride Height, with Shock Absorbers
16010	COWL Flat Back
16HCV	GAUGE CLUSTER English with English Electronic Speedometer, for Electric Vehicle
16VCD	DASH INSULATOR
27DUW	WHEELS, FRONT {Accuride 51408} DISC; 22.5x8.25 Rims, Powder Coat Steel, 2-Hand Hole, 10-Stud, 285.75mm BC, Hub-Piloted, Flanged Nut, with Steel Hubs
28DUW	WHEELS, REAR {Accuride 51408} DUAL DISC; 22.5x8.25 Rims, Powder Coat Steel, 2-Hand Hole, 10-Stud, 285.75mm BC, Hub-Piloted, Flanged Nut, with Steel Hubs
47AGK	BODY, BUS Conventional; 78" Headroom, 34'2" Body Length, 77 Passenger, 276" WB
47AJC	BODY TAG, METAL Capacity to Include the Total Number of Passengers

Vehicle Specifications
2023 Electric CE S Bus (PB10E)

June 16, 2022

Code	Description
47APR	HEADLINER, BODY Conventional; 25'11"-34'11" Body Length, Perforated Full Length with Sound Insulation Full Length
47APW	FASTENERS, HEADLINER Rivets
47ARH	BOWS, ROOF 14 ga., One Piece Construction
47ARP	LIGHT BARS Plastic
47ATB	SKIRT, BODY Conventional, 20", 16ga., 31'2", 31'11", 32'8", 33'5", 34'2", 34'11", 35'8" Body Lengths
47AUR	TIE DOWNS, BODY Grade 8 Bolts, Every Body Section
47AXT	RUB RAILS, BODY (4) Conventional; Steel, 31'2", 31'11", 32'8", 33'5", 34'2", 34'11", 35'8" Body Lengths, Includes Snow Rail
47AYB	BODY, REAR Includes Emergency Door
47AZE	SIDE SHEET, BODY, EXTERIOR Conventional, 16ga., Smooth, 31'2", 31'11", 32'8", 33'5", 34'2", 34'11", 35'8" Body Lengths
47AZL	FLOOR, BODY with Wheel Wells
47AZX	RAILS, WRAP-AROUND, FLOOR At Floor Level To Rear Door Post
47AZZ	RAILS, WRAP-AROUND Just Below Window Line
47BAK	BUMPER, REAR Painted, 12" High, 3/16" Thick
47BAR	SUPPORTS, REAR BUMPER Bolted to Frame
47BBH	LINING, SIDE INTERIOR, LOWER Embossed Steel, Clear Coated
47BBZ	SEALER Extra; Sidewall to Floor, In Wheel Pocket Area, and Rear Wall to Floor
47BLD	STEP, FRONT ENTRANCE DOOR 27 1/4" Depth; 14ga Steel, Formed Treads, Naviflex Finish
47DAJ	COVER, REAR DOOR INSIDE HANDLE Partial Coverage
47DAK	FASTENERS, REAR DOOR Bolts and Nutserts, Rear Door To Body
47DBP	DOOR, ENTRANCE, FRONT Air, Outward Opening, with Split Pane Glass
47DDE	HANDLE, ASSIST, ENTRANCE DOOR Outside Entrance
47DDH	HOLD BACK, REAR DOOR Stationary, No Cables, with Plastic Cover
47DDU	LATCH, REAR DOOR One Point Slide Bar, Cam Operated, with One Inch Stroke
47DEK	LOCK, REAR DOOR with Ignition Starter Interlock
47DEY	HANDLE, EXTERIOR, REAR Emergency Door; Yellow
47DNK	SWITCH, LOCATION Steering Wheel; Includes Master Flasher, Flasher On/Off, Red Override, and Door Control
47DWU	KEYS ALIKE, BATTERY BOX , 545 Keys
47DWV	KEYS ALIKE, LOCKS Entrance Door, 545 Keys
47EBD	LOCK, BATTERY COMPARTMENT Standard Location
47EBM	HOLD DOWN, BATTERY For (2) Standard Size Batteries
47ETK	COMPARTMENT, LUGGAGE, RT AFT 79" x 20" x 18"
47EXK	LOCK, ENTRANCE DOOR Integrated Manual Control in Door, with Key

Vehicle Specifications
2023 Electric CE S Bus (PB10E)

June 16, 2022

<u>Code</u>	<u>Description</u>
47KDC	MONITOR, POST TRIP INSPECTION {Leave No Student Behind} Accessory Controlled, with Push Button Alarm Disable at Rear of Bus in Light Bar Prompts Driver to Walk to Back of Bus to Disable Alarm
47LAB	NOISE REDUCTION, DRIVER FLOOR Insulation Covering Complete Driver Floor Area
47LAT	NOISE REDUCTION, ROOF BOW Conventional; Insulation, 31'2", 31'11", 32'8", 33'5", 34'2", 34'11", 35'8" Body Lengths
47LAU	INSULATION,ROOF/SIDES/BULKHEAD 1.5"
47MBA	UNDERCOAT, BODY Fire Resistant, Water Based, TT-C-730 Spec
47MJR	LETTERS, DOOR, REAR Decals; "EMERGENCY DOOR", 2" Black Letters Inside and Outside
47MNM	LETTERS, BATTERY COMPARTMENT (01) Decal; "Battery"; 2" Black Letters, Centered on Standard Battery Box
47MNT	ARROW, RR DOOR, INSIDE Decal; Red, .75" Stroke, Indicating Handle Direction
47MNV	ARROW, RR DOOR, OUTSIDE Decal; Black .75" Stroke, Indicating Handle Direction
47MPD	LETTERS, SCHOOL BUS FRONT/REAR Decal; "SCHOOL BUS"; with 8" Black Reflective Letters, Reflexite V82, On Front and Rear Cap
47MRN	STRIPING, E/E WINDOW, LEFT (02) Perimeter, Reflexite V82, 1" Yellow
47MRU	LETTERS, E/E WINDOW, LEFT (2) Decal Sets, "EMERGENCY EXIT", Black Inside and Outside
47MSA	STRIPING, PERIMETER, REAR Emergency Door, Reflexite 1" Yellow Reflective
47MSE	STRIPING, REAR END Reflexite 2" Yellow
47MSJ	STRIPING, ROOF HATCH, FRONT Reflexite Decal, Perimeter, 1" Yellow
47MSK	STRIPING, ROOF HATCH, REAR Reflexite Decal, Perimeter, 1" Yellow
47MSS	STRIPING, SEATLINE Reflexite V82, 2" Yellow
47MTY	WIRING DIAGRAM Schematic, Electrical
47MUP	STRIPING, E/E WINDOW, RIGHT (02) Perimeter, Reflexite V82, 1" Yellow
47MVA	LETTERS, HEADER Decal; "WATCH YOUR STEP", 1" Black, Above Windshield
47MVC	LETTERS, STEPWELL Decal, "WATCH YOUR STEP", 2.5" Black, Behind Door on Step Riser
47NAB	PAINT COLOR, RUB RAILS 0001 Canyon Black
47NGT	PAINT HOOD TOP 4422 Yellow, Non-Reflecting
47NGW	SEAL, RUB RAILS Top Edge, All Rails
47NHL	LETTERS, E/E WINDOW, RIGHT (2) Decal Sets, "EMERGENCY EXIT", Black, Inside and Outside
47NJA	PAINT COLOR, BODY EXTERIOR 4421 School Bus Yellow
47NJM	PAINT FLASHER BACKGRD 0001 Canyon Black
47NJS	PAINT COLOR, BUMPER Rear, 0001 Canyon Black
47NKD	PAINT COLOR, ROOF 9219 Winter White, Beginning 5" Above Drip
47NKL	PAINT, RUB RAIL Flange to Flange
47NKM	PAINT COLOR, BODY INTERIOR 9384 Spring White
47NMG	OPERATING INSTR, REAR Decal, Inside Rear Emergency Door

Vehicle Specifications
2023 Electric CE S Bus (PB10E)

June 16, 2022

Code	Description
47NTE	LOGO, ROOF LINE Decal; Wing and Shield, First Body Section, Above Driver Window and Entrance Door Over Driver Window and Entrance Door
47NXW	DECAL, BUMPERS Yellow Numbers, Front and Rear
47PAR	BODY CERTIFICATION TAG Mylar Label, with Actual Tire Load Rating
47PCG	HANDLE, ASSIST Windshield Side Mounted, Left and Right, Body Color, with Certain Mirrors Only
47SBS	SUB FLOOR, PLYWOOD Conventional; B-C Exterior Grade, Less Sealed Edges, 5/8", 5 Ply, for 31'2", 31'11", 32'8", 33'5", 34'2", 34'11", 35'8" Body Lengths
47SPJ	ALPHA/NUMERIC DECAL GUIDE Quantity 081-90
48ACN	SEAT BELT, DRIVER, COLOR with Blaze Orange Seat Belt Webbing
48ANT	WINDOW, DRIVER Laminated, Clear
48APL	WINDOW, STOPS 12" Opening, Only with 78" Headroom
48ARW	WINDOW, SASH (22) 27" Sections, 9"x 23" Opening
48BAH	WINDOW, E/E, LEFT (2) Vertical Hinge
48BJA	COLOR, WINDOW FRAME, PASS Passenger Window, Natural Aluminum Finish
48BKP	WINDOW, E/E, RIGHT (2) Vertical Hinge
48BUB	WINDOW, PASSENGER, TINT Conventional; 28% Light, Tempered Glass, 78" Headroom, with 34'11", 31'2", 31'11", 32'8", 33'5", 34'2", 35'8" Body Lengths
48CGB	HEATER, PASSENGER (UWE P90) Convection Type, with 34'2" Body Length
48CMY	UPHOLSTERY, DRIVER SEAT, COLOR 2-Tone Gray
48CXZ	AIR CONDITIONER, BODY IC Air, 120,000 BTU, Evaporators ProAir Front & Rear Flush Mounted, Condensers ProAir Skirt Mounted, Electric Compressors, with ProAir Control System
48GHC	HEATER, DRIVER 90,000 BTU, with Defroster and without Rear Heat Duct
48NAT	FITTINGS, AIR SEAT for Driver Seat
48PAM	WINDSHIELD 3 Flat Pieces, 73% Light, with Band
48PAV	WHEEL POCKET COVER Plastic, ABS
48PAY	AISLE POSITION Center, for balanced seating
48PEW	FLOOR COVERING, COLOR Gray #766
48PJZ	FLOOR COVERING, TYPE {Koroseal} All Body Lengths
48PKM	FLOOR COVERING, TRIM {Koroseal} Plastic Base with PVC Cap
48PKS	FAN, DEFOG RIGHT CENTER 6.50" Diameter, Black, Mounted Over Windshield, 15" Right of Centerline, 2-Speed Switch in Panel
48PPS	ROOF VENT, FRONT Static
48PTT	ARM REST, DRIVER, RIGHT (National)
48PUT	NUTS, BELT MOUNTING Standard Nuts For Seat Belt Mounting
48PVB	UPHOLSTERY, DRIVER SEAT, STYLE Plain
48PWD	UPHOLSTERY, PASS SEATS, COLOR Gray, for Seats, Barriers and Head Bumpers
48PWZ	UPHOLSTERY, DRIVER SEAT, TYPE Fabric

Vehicle Specifications
2023 Electric CE S Bus (PB10E)

June 16, 2022

<u>Code</u>	<u>Description</u>
48PXA	UPHOLSTERY, BARRIER, TYPE (1-2) Vinyl, 42 oz.
48RAE	BARRIER, CRASH, AFT ENTRY DOOR 39", 1 Leg
48RAL	BARRIER, CRASH, AFT DRIVER 39", 1 Leg
48REP	PANEL, MODESTY, AFT OF DRIVER Mounted Under Barrier
48RET	PANEL, MODESTY, AFT ENTR DOOR Mounted Under Barrier
48RGE	HAND RAIL, ENTRANCE DOOR, FWD Stainless Steel; Curved
48RGR	HAND RAIL, ENTRANCE DOOR, AFT Stainless Steel, 4", Above Step
48RLX	CUSHION, SEAT 15" Depth
48RRA	UPHOLSTERY, SEAT, STITCHING Single
48RTL	SEAT, TRACK, LT, 39", 2 LEG (3)
48RTS	SEAT, TRACK, RT, 39", 2 LEG (2)
48RUN	SEAT, TRACK, LT, 39", 4 LEG (8)
48RXX	SEAT, TRACK, RT, 39", 4 LEG (9)
48SBG	UPHOLSTERY, PASS SEATS, TYPE Vinyl, 42 Ounce
48TZK	SEAT, DRIVER {National Premium} Air Suspension with Suspension Skirt, Triple Chamber Adjustable Air Lumbar, Adjustable Cushion and Back Bolsters, 6 Position Front Cushion Adjuster, 3 Position Rear Cushion Adjuster, 6 to 23 Degree Back Recline
48USV	SEAT BACK, PASSENGER High Back
48UZN	ROOF HATCH, FRONT {Specialty Hybrid Adv H1975-025-191-0F} Emergency Exit with Outside Release, Alarm, English Decals
48UZT	ROOF HATCH, REAR {Specialty Hybrid Adv H1975-025-191-0F} Emergency Exit with Outside Release, Alarm, English Decals
48VVR	STEP TREADS {Koroseal} Pebble White Nosing Only, with Non-Metal Backing, used with Formed Treaded Steps
49001	BODY PLAN, APPROVED VARIATION Number 001
49AHV	LIGHT, STROBE, STOP SIGN, FRT In Lieu Of Flashing Lights Furnished with Stop Sign, Speciality
49AMD	SWITCH, DRIVER PANEL, TYPE Rocker
49AMJ	ALARM, BACKING {Ecco #575} 107 dB
49AMT	CIRCUIT, PROTECTION Breakers, Manual Reset in Lieu of Fuses
49AMY	SWITCH, REAR DOOR BUZZER for Emergency Door
49ANH	SWITCH, MAGNETIC, DISCONNECT Master, Ignition Operated, All Body Circuits
49ANU	SOURCE, POWER 12 VDC, Mounted In Dash
49AUM	SWITCH, MASTER FLASHER Omit Master Flasher Switch, 8-Lamp System
49AWV	SPEAKERS AND WIRING (8) Flush Mounted In Light Bar
49BCL	FLASHER SYSTEM (8) Warning Lights, 8-Lamp System, Electronic Relay Flasher, Sequential Operation, Red Lights Activate after Amber Lights, with Road Speed Parameters
49BCR	LIGHT, EXTERIOR, CHECK Automatically Activates Lights for Pre Trip Inspection
49BEW	MIRROR, REAR VIEW, EXTERIOR {Mirror Lite Super Nickels} Black, Motorized Head, Heated

Vehicle Specifications
2023 Electric CE S Bus (PB10E)

June 16, 2022

<u>Code</u>	<u>Description</u>
49BMA	STOP ARM, FRONT {Specialty 2980} Air, 18" Octagon, Double Sided, 1/2" White Border, Hi Intensity Grade, Strobing LED Lights
49BUT	VISOR, INTERIOR, LEFT FRONT 6" x 30", Transparent, For Left Windshield, with Finger Hold Adjustment Knob
49BVE	MIRROR, CROSS VIEW, EXTERIOR (2) {Mirror Lite High Definition Busboy} Black
49BYT	LIGHTS, STOP (2) {Sound Off/OptiLuxx} and Tail; 7" Round LED, Red
49BYZ	LIGHTS, DIRECTIONAL, REAR (2) {Sound Off/OptiLuxx} LED, 7" Round Amber
49BZG	LIGHTS, BACK UP (2) {Sound Off/OptiLuxx} LED, 7" Round Clear
49CLM	RADIO, ENTERTAINMENT AM/FM/USB Input/Auxiliary Input, Includes Antenna and Cable, with Public Address System
49DAG	LIGHT, INDIC, WARNING LIGHTS LED Type; Red and Amber
49DBR	HOOD, WARNING LAMP (4) Black, 8-Lamp System, One Hood Above Two Lights
49EAX	LIGHTS, DIRECTIONAL, SIDE (4) {Sound Off/OptiLuxx} Rectangular LED Armored, 2 Each Side First Section Aft Entrance Door & Forward Rear Wheel Pocket
49ENR	VISOR, INTERIOR, DRIVER LEFT 10" X 30" for Driver's Window
49ESC	LIGHTS, DOME, DRIVER {Sound Off/OptiLuxx} (1) LED, Rectangular, Mounted in Light Bar in Ceiling, with Separate Switch
49EUB	KIT, FIRST AID Metal; 24 Unit, Spec State
49EVL	SWITCH, NOISE SUPPRESSION Actuator Legend States, "NOISE SUPP ", for Separate Solenoid, with Red Switch in Panel
49GBG	KIT, BODY FLUID Arizona, Mounted on the Bulkhead
49GBV	WINDSHIELD WIPERS (2) Cowl Mounted
49GDG	PADDING COMPART ABOVE DRIVER Window; Safety Equipment Compartment, with Cutout for Dome Light
49GDS	COMPARTMENT ABOVE DRIVER Left of the Driver
49GGE	FIRE EXTINGUISHER, DRIVER AREA 5 lb 2A-40BC Minimum, with Flexible Hose and Metal Nozzle
49GHN	REFLECTORS, REAR (2) 3", Red, Adhesive Back
49GHR	REFLECTORS, SIDE, REAR (2) 3", Red, Adhesive Back
49GHV	REFLECTORS, SIDE, FRONT (2) 3", Amber; Adhesive Back, 1 Aft Drivers Window Left, 1 Aft Entrance Door Right
49GHX	REFLECTORS, SIDE, INTERMEDIATE (2) 3" Amber, 1 Each Side, Below The Third Rub Rail From the Top, Adhesive Back
49GKL	SAFETY TRIANGLES 1 Kit; Warning Reflectors, Mounted on Floor Between Driver Seat and Drivers Crash Barrier/Stanchion
49GUK	FENDERS, RUBBER, REAR (2)
49GUX	MUD FLAPS, FRONT WHEELS (2) Rubber
49GVC	MUD FLAPS, REAR WHEELS (2) Rubber
49GWW	WINDSHIELD WASHER Kit; 6 Quart Capacity, Bottle
49JAK	TRACK, FLOOR LENGTHS 651"-700", Less Shoulder Track
49JAL	TRACK, COVER

Vehicle Specifications
2023 Electric CE S Bus (PB10E)

June 16, 2022

<u>Code</u>	<u>Description</u>
49JBG	TRACK, TYPE (BRAND) {OMNI L Track}
49JBP	LIGHTS, DOME {Sound Off/OptiLuxx} {07} LED, Rectangular Recessed Type, Mounted in Light Bar
49JBS	LIGHTS, CLUSTER {Sound Off/OptiLuxx} Oval, 4 Internal LEDs per Light; Amber Front and Red Rear
49JBX	LIGHT, STEP {Sound Off/OptiLuxx} 4" Round LED, White, Wired to Ignition, Operated by Entrance Door
49JBY	LIGHTS, MARKER, FRONT & REAR (4) {Sound Off/OptiLuxx} LED, Armored, Slim-Line, (2) Amber Front and (2) Red Rear
49MRN	MIRROR, INSIDE 6" x 30" with Lever Lock
49MZV	LATCH, COMPARTMENT Locking, for Overhead Storage Compartment
49NGB	LIGHT, COMPARTMENT, ENGINE {Sound Off/OptiLuxx} LED 4" Oval; Activated with Parking Lights, with On/Off Switch, Includes Limit Switch that Allows Light to come on When Hood is Opened
49NGG	LIGHTS, TAIL, LICENSE PLATE (2) {Sound Off/OptiLuxx} 4" Round LED, Red, Includes Stop & Light Window, Includes Mounting Gasket
49NGJ	LIGHTS, WARNING (8) {Sound Off/OptiLuxx} (4) 7" Round Red Strobing LED and (4) 7" Round Amber Strobing LED, 2 Front, 2 Rear Each Color
49UAC	STATE OF OPERATION Arizona
49ZNE	LIGHTS, MARKER, SIDE, INTERMED {Sound Off/OptiLuxx} LED, Amber, Slim-Line, Armored, Intermediate, Centered, Required for Units 30 Foot or Longer
50YSD	BODY PLAN, NON-SPECIAL NEEDS Electric Vehicle; 34' 02" Body Length, 66 Passenger, 276" WB, DK0029A000
7382135443	(2) TIRE, FRONT 11R22.5 Load Range H ECOPLUS HS3+ (CONTINENTAL), 495 rev/mile, 75 MPH, All-Position
7382135443	(4) TIRE, REAR 11R22.5 Load Range H ECOPLUS HS3+ (CONTINENTAL), 495 rev/mile, 75 MPH, All-Position

Services Section:

40133	WARRANTY Standard for Electric School Bus Models, Effective with Vehicles Built October 1, 2020 or Later, CTS-3310
40RAT	SERVICES, TOWING {Navistar} Service Call to 60-Month/Unlimited Mileage to the Nearest IC Bus Dealer for Navistar Warrantable Failure as Contract Defined; Includes Engine Failure if Supplier Declines Tow Coverage & ESC Supplied thru Navistar; \$1100 (USA) Maximum Benefit per Incident
49GVN	WARRANTY 5-Year, Limited

Body/Allied Equipment

<u>Code</u>	<u>Description</u>
<u>Goods Purchased</u>	
<u>Code</u>	<u>Description</u>

Turning Radius Summary
2023 Electric CE S Bus (PB10E)

June 16, 2022

Series: INGB
 Model: PB10E
 Description: Electric CE S Bus
 Model Year: 2023

Calculation Factors

Wheelbase: 276
 Front Axle: 0002ASH
 Description: AXLE, FRONT NON-DRIVING, {Meritor MFS-10-122A} I-Beam Type, 10,000-lb Capacity
 Front Wheel: 0027DUW
 Description: WHEELS, FRONT, {Accuride 51408} DISC; 22.5x8.25 Rims, Powder Coat Steel, 2-Hand Hole, 10-Stud, 285.75mm BC, Hub-Piloted, Flanged Nut, with Steel Hubs
 Front Tire: 07382135443
 Description: TIRES, 11R22.5 Load Range H ECOPLUS HS+ (CONTINENTAL), 495 rev/mile, 75 MPH, All-Position
 Steering Gear: 0005PRR
 Description: STEERING GEAR, {TRW (Ross) TAS66} Power

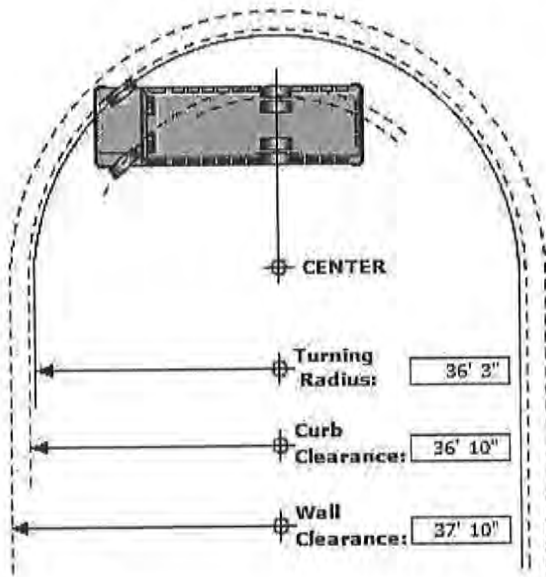

Turning Radius Statistics

General Information

Inside Turn Angle: 50 Degrees
 Radial Overhang: 19

Axle Information

KingPin Inclination: 6.25 Degrees
 KingPin Center: 69

Turning Radius - Curb View

C	- Curb Contact Length:	15.95
CI	- Curb Clearance Increment:	6.14
CR	- Curb Clearance Radius:	36'10"
CH	- Curb Height:	6"
TR	- Turning Radius:	36'3"
TW	- Tire Width:	11.70

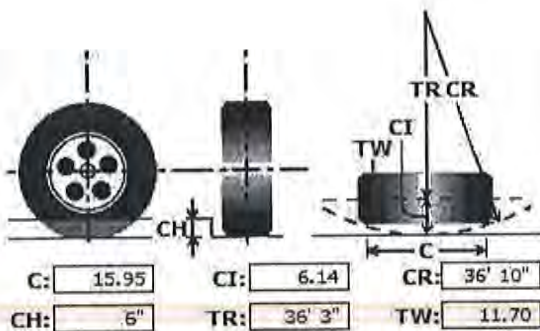

* All Measurements are in inches, unless otherwise specified.

This information is based on engineering information available at this time. Actual figures may vary. Navistar, Inc. cannot accept liability for consequences due to this variance.

Date: 3/10/23
 Quote Valid Until:
 Prepared By: TOM HARTMAN



Name:
 Organization: EQUALIS GROUP
 Address:
 City, State ZIP:
 Phone:

YEAR:	2024
MAKE:	IC
MODEL:	CE EV
CAPACITY:	72-77
STOCK #'S:	RWCICCE-2

		INCLUDES 3 CAMERA SYSTEM AND DVR INCLUDES AC SYSTEM EV FREEBLOW	\$ 510,000.00
TRADE BUS #:		Trade Total:	\$ -
		Pre Tax Sub Total:	\$ 510,000.00
		Sales Tax ():	\$ -
		Local Delivery Charge: 0	\$ -
			\$ -
		TOTAL PRICE:	\$ 510,000.00

RWC ICE-2 EV Bus $\frac{72}{77}$ passengers

February 23, 2022

Prepared For:
RWC International Ltd
TOM HARTMAN
2202 S Central Ave.
Phoenix, AZ 85004-2908
(602)307 - 1050
Reference ID: CE3411-276-77E

Presented By:
RWC Group
Julie Shockley
600 North 75th Avenue
PHOENIX AZ 85043 -
(602)307-1050

Model Profile
2023 Electric CE S Bus (PB10E)

APPLICATION:	School Transportation
MISSION:	Requested GVWR: 33000. Calc. GVWR: 33000 Calc. Start / Grade Ability: 0.00% / 0.00% @ 0 MPH Calc. Geared Speed: N/A
DIMENSION:	Wheelbase: 276.00, CA: N/A, Axle to Frame: 157.00
MOTOR, ELECTRIC, DRIVETRAIN:	{Dana TM4 SUMO MD HV2200-6P} 255kW Rated Power @ 1000 RPM, 2355 Nm Rated Torque @ 1000 RPM
CLUTCH:	Omit Item (Clutch & Control)
AXLE, FRONT NON-DRIVING:	{Meritor MFS-10-122A} I-Beam Type, 10,000-lb Capacity
AXLE, REAR, SINGLE:	{Dana Spicer S23-172F} Single Reduction, Pinion Up, 23,000-lb Capacity, R Wheel Ends Gear Ratio: 6.83
TIRE, FRONT:	(2) 11R22.5 Load Range H ECOPLUS HS3+ (CONTINENTAL), 495 rev/mile, 75 MPH, All-Position
TIRE, REAR:	(4) 11R22.5 Load Range H ECOPLUS HS3+ (CONTINENTAL), 495 rev/mile, 75 MPH, All-Position
SUSPENSION, REAR, AIR, SINGLE:	{International IROS} 23,000-lb Capacity, 9.25" Ride Height, with Shock Absorbers
PAINT:	Cab schematic 101NB Location 1: 4421, School Bus Yellow (Std) Location 2: 4422, School Bus Yellow Non Reflective (Nrf) Chassis schematic N/A

Vehicle Specifications
2023 Electric CE S Bus (PB10E)

February 23, 2022

Code	Description
PB10E00	Base Chassis, Model Electric CE S Bus with 276.00 Wheelbase, N/A CA, and 157.00 Axle to Frame.
1570	TOW HOOK, FRONT (2) Frame Mounted
1CGL	FRAME RAILS Heat Treated Alloy Steel (120,000 PSI Yield); 10.125" x 3.062" x 0.312" (257.2mm x 77.8mm x 8.0mm); 480.1" (12195mm) Maximum OAL
1LLE	BUMPER, FRONT Contoured, Steel, Severe Duty
1LNT	CROSSING GATE, FRONT Omit Item
1SAM	CROSSMEMBER, REAR, AF (2)
1WJE	WHEELBASE RANGE 276" (700cm) Only
1WRP	TOW HOOK, REAR (2) Mounted on Lower Rail Flange
2ASH	AXLE, FRONT NON-DRIVING {Meritor MFS-10-122A} I-Beam Type, 10,000-lb Capacity
3ADB	SUSPENSION, FRONT, SPRING Parabolic Taper Leaf, Shackle Type, 10,000-lb Capacity, with Shock Absorbers
4091	BRAKE SYSTEM, AIR Dual System for Straight Truck Applications
4AZS	AIR BRAKE ABS {Bendix AntiLock Brake System} 4-Channel (4 Sensor/4 Modulator) Electronic Stability Program, with Automatic Traction Control
4EBT	AIR DRYER {Bendix AD-IP} with Heater
4SPS	AIR COMPRESSOR {Quanxing} 10.6 CFM, for Electric Vehicle
4VLN	AIR TANK LOCATION (2) Mounted Outside Right Rail, Side by Side, Back of Stepwell, for Electric Vehicle
4WWX	DRAIN VALVE {Humphrey} (3) Air Operated, with Controls in Drivers Compartment, for Air Tanks
4WZT	GVWR LIMITATION FOR BUS with Air Brakes, Limited to 33,000-lbs Maximum to meet FMVSS 121 Requirements, for Conventional Bus
4XCJ	BRAKES, FRONT {Bendix Spicer ADB22X} Air Disc Type, Extended Service, Size 22.5", 23,000-lb Capacity
4XCK	BRAKES, REAR {Bendix Spicer ADB22X} Air Disc Type, Extended Service, Size 22.5", 26,000-lb Capacity per Axle
4XDW	BRAKE CHAMBERS, FRONT AXLE 18 SqIn, for Air Disc Brakes
4XEA	BRAKE CHAMBERS, REAR AXLE 18/24 SqIn Spring Brake, Double Diaphragm, for Air Disc Brakes
5710	STEERING COLUMN Tilting and Telescoping
5CAL	STEERING WHEEL 2-Spoke, 18" Dia., Black
5PRR	STEERING GEAR {TRW (Ross) TAS66} Power
6DGL	DRIVELINE SYSTEM {Dana Spicer} Service Free SPL170, for 4x2/6x2
8000	ELECTRICAL SYSTEM 12-Volt, Standard Equipment
8MVY	BATTERY SYSTEM {Energys Odyssey 31-PC2150 AGM} Maintenance-Free, (2) AGM 12-Volt 2300CCA Total, Top Threaded Stud
8TLD	BATTERY PACK 315 kWh Capacity
8TTK	BATTERY BOX Steel, with Sliding Tray, 25.25" Wide, for Standard Batteries, 1-3 Battery Capacity, Mounted Left Side Behind Front Axle Perpendicular to Frame Rail
8VBD	HORN, ELECTRIC (2) Trumpet Style, Mounted Above Right Frame Rail
8WPB	HEADLIGHTS Halogen, Composite Aero Design, with Daytime Running Lights

Vehicle Specifications
2023 Electric CE S Bus (PB10E)

February 23, 2022

<u>Code</u>	<u>Description</u>
8WSU	CHARGING PORT Forward Location, for Electric Vehicle
	<u>Includes</u> : CHARGING PORT Forward Charging Port Located Right Side Aft of Entrance Door
8WUC	POWER CONVERTER HV Battery to 12V Battery, with Dual Converters, for Electric Vehicle
8WWJ	INDICATOR, LOW COOLANT LEVEL with Audible Alarm
8WXB	HEADLIGHT WARNING BUZZER Sounds When Head Light Switch is on and Ignition Switch is in "Off" Position
8XAH	CIRCUIT BREAKERS Manual-Reset (Main Panel) SAE Type III with Trip Indicators, Replaces All Fuses
8XNX	SOUND GENERATOR for Electric Vehicle
9WAB	HOOD TILT ASSIST {EASY TILT} Mechanical
9WAY	FRONT END Tilting, Fiberglass, with Three Piece Construction
10020	CHASSIS PAINT Full Chassis
10063	PAINT SCHEMATIC, PT-1 Two Tone, Design 101 for Non-Reflecting Schoolbus Hood
10661	PAINT, NON-REFLECTING Non-Reflecting Paint
10788	PAINT TYPE Urethane, One or Two Colors, Other than Imron or International.
10AEP	FLEET HEALTH MONITOR REPORTING for 60 Months
10AET	ADVANCED PREVENTIVE MAINT for 60 Months
10AEY	COMMUNICATIONS MODULE Telematics Device; Includes Two Year Data Plan
10WHJ	SPECIAL ROUTING CONTROL To Bus Vehicle Modification Center
10WLM	SPECIAL ROUTING CONTROL WIFI to CBC for Kajeet WiFi Installation; Contact CBC for Quote/Pricing
11001	CLUTCH Omit Item (Clutch & Control)
12703	ANTI-FREEZE Red, Extended Life Coolant; To -40 Degrees F/ -40 Degrees C, Freeze Protection
12AAB	MOTOR, ELECTRIC, DRIVETRAIN {Dana TM4 SUMO MD HV2200-6P} 255kW Rated Power @ 1000 RPM, 2355 Nm Rated Torque @ 1000 RPM
12VVN	CRUISE CONTROL Electronic
12VWH	GOVERNOR Electronic Road Speed Type; for Electronic Engines and Bus Models; with 55 MPH Default
12XCJ	RADIATOR Aluminum, 2-Row, Cross Flow, Four 12" E-Fan System, 595 SqIn Louvered, for Electric Vehicle
14ERW	AXLE, REAR, SINGLE {Dana Spicer S23-172F} Single Reduction, Pinion Up, 23,000-lb Capacity, R Wheel Ends . Gear Ratio: 6.83
14TBT	SUSPENSION, REAR, AIR, SINGLE {International IROS} 23,000-lb Capacity, 9.25" Ride Height, with Shock Absorbers
16010	COWL Flat Back
16HCV	GAUGE CLUSTER English with English Electronic Speedometer, for Electric Vehicle
16VCD	DASH INSULATOR
27DUW	WHEELS, FRONT {Accuride 51408} DISC; 22.5x8.25 Rims, Powder Coat Steel, 2-Hand Hole, 10-Stud, 285.75mm BC, Hub-Piloted, Flanged Nut, with Steel Hubs
28DUW	WHEELS, REAR {Accuride 51408} DUAL DISC; 22.5x8.25 Rims, Powder Coat Steel, 2-Hand Hole, 10-Stud, 285.75mm BC, Hub-Piloted, Flanged Nut, with Steel Hubs
47AJC	BODY TAG, METAL Capacity to Include the Total Number of Passengers

Vehicle Specifications
2023 Electric CE S Bus (PB10E)

February 23, 2022

<u>Code</u>	<u>Description</u>
47AMG	BODY, BUS Conventional; 78" Headroom, 34'11" Body Length, +9 Section Rear, 78 Passenger, 276 WB
47APR	HEADLINER, BODY Conventional; 25'11"-34'11" Body Length, Perforated Full Length with Sound Insulation Full Length
47APW	FASTENERS, HEADLINER Rivets
47ARH	BOWS, ROOF 14 ga., One Piece Construction
47ARP	LIGHT BARS Plastic
47ATB	SKIRT, BODY Conventional, 20", 16ga., 31'2", 31'11", 32'8", 33'5", 34'2", 34'11", 35'8" Body Lengths
47AUR	TIE DOWNS, BODY Grade 8 Bolts, Every Body Section
47AXT	RUB RAILS, BODY (4) Conventional; Steel, 31'2", 31'11", 32'8", 33'5", 34'2", 34'11", 35'8" Body Lengths, Includes Snow Rail
47AYB	BODY, REAR Includes Emergency Door
47AZE	SIDE SHEET, BODY, EXTERIOR Conventional, 16ga., Smooth, 31'2", 31'11", 32'8", 33'5", 34'2", 34'11", 35'8" Body Lengths
47AZL	FLOOR, BODY with Wheel Wells
47AZX	RAILS, WRAP-AROUND, FLOOR At Floor Level To Rear Door Post
47AZZ	RAILS, WRAP-AROUND Just Below Window Line
47BAK	BUMPER, REAR Painted, 12" High, 3/16" Thick
47BAR	SUPPORTS, REAR BUMPER Bolted to Frame
47BBH	LINING, SIDE INTERIOR, LOWER Embossed Steel, Clear Coated
47BBZ	SEALER Extra; Sidewall to Floor, In Wheel Pocket Area, and Rear Wall to Floor
47BKE	LOCK, HEATER COMPARTMENT
47BLD	STEP, FRONT ENTRANCE DOOR 27 1/4" Depth; 14ga Steel, Formed Treads, Naviflex Finish
47DAJ	COVER, REAR DOOR INSIDE HANDLE Partial Coverage
47DAK	FASTENERS, REAR DOOR Bolts and Nutserts, Rear Door To Body
47DBP	DOOR, ENTRANCE, FRONT Air, Outward Opening, with Split Pane Glass
47DDE	HANDLE, ASSIST, ENTRANCE DOOR Outside Entrance
47DDH	HOLD BACK, REAR DOOR Stationary, No Cables, with Plastic Cover
47DDU	LATCH, REAR DOOR One Point Slide Bar, Cam Operated, with One Inch Stroke
47DEK	LOCK, REAR DOOR with Ignition Starter Interlock
47DEY	HANDLE, EXTERIOR, REAR Emergency Door; Yellow
47DNK	SWITCH, LOCATION Steering Wheel; Includes Master Flasher, Flasher On/Off, Red Override, and Door Control
47DWU	KEYS ALIKE, BATTERY BOX , 545 Keys
47DWW	KEYS ALIKE, LOCKS Entrance Door, 545 Keys
47EBD	LOCK, BATTERY COMPARTMENT Standard Location
47EBM	HOLD DOWN, BATTERY For (2) Standard Size Batteries
47ETK	COMPARTMENT, LUGGAGE, RT AFT 79" x 20" x 18"

Vehicle Specifications
2023 Electric CE S Bus (PB10E)

February 23, 2022

<u>Code</u>	<u>Description</u>
47EXK	LOCK, ENTRANCE DOOR Integrated Manual Control in Door, with Key
47KDC	MONITOR, POST TRIP INSPECTION {Leave No Student Behind} Accessory Controlled, with Push Button Alarm Disable at Rear of Bus in Light Bar Prompts Driver to Walk to Back of Bus to Disable Alarm
47LAB	NOISE REDUCTION, DRIVER FLOOR Insulation Covering Complete Driver Floor Area
47LAT	NOISE REDUCTION, ROOF BOW Conventional; Insulation, 31'2", 31'11", 32'8", 33'5", 34'2", 34'11", 35'8" Body Lengths
47LAU	INSULATION, ROOF AND SIDES 1.50", All Models
47MBA	UNDERCOAT, BODY Fire Resistant, Water Based, TT-C-730 Spec
47MJR	LETTERS, DOOR, REAR Decals; "EMERGENCY DOOR", 2" Black Letters Inside and Outside
47MNM	LETTERS, BATTERY COMPARTMENT (01) Decal; "Battery"; 2" Black Letters, Centered on Standard Battery Box
47MNT	ARROW, RR DOOR, INSIDE Decal; Red, .75" Stroke, Indicating Handle Direction
47MNV	ARROW, RR DOOR, OUTSIDE Decal; Black .75" Stroke, Indicating Handle Direction
47MPD	LETTERS, SCHOOL BUS FRONT/REAR Decal; "SCHOOL BUS"; with 8" Black Reflective Letters, Reflexite V82, On Front and Rear Cap
47MRN	STRIPING, E/E WINDOW, LEFT (02) Perimeter, Reflexite V82, 1" Yellow
47MRU	LETTERS, E/E WINDOW, LEFT (2) Decal Sets, "EMERGENCY EXIT", Black Inside and Outside
47MSA	STRIPING, PERIMETER, REAR Emergency Door, Reflexite 1" Yellow Reflective
47MSE	STRIPING, REAR END Reflexite 2" Yellow
47MSJ	STRIPING, ROOF HATCH, FRONT Reflexite Decal, Perimeter, 1" Yellow
47MSK	STRIPING, ROOF HATCH, REAR Reflexite Decal, Perimeter, 1" Yellow
47MSS	STRIPING, SEATLINE Reflexite V82, 2" Yellow
47MTY	WIRING DIAGRAM Schematic, Electrical
47MUP	STRIPING, E/E WINDOW, RIGHT (02) Perimeter, Reflexite V82, 1" Yellow
47MVA	LETTERS, HEADER Decal; "WATCH YOUR STEP", 1" Black, Above Windshield
47MVC	LETTERS, STEPWELL Decal, "WATCH YOUR STEP", 2.5" Black, Behind Door on Step Riser
47NAB	PAINT COLOR, RUB RAILS 0001 Canyon Black
47NGT	PAINT HOOD TOP 4422 Yellow, Non-Reflecting
47NGW	SEAL, RUB RAILS Top Edge, All Rails
47NHL	LETTERS, E/E WINDOW, RIGHT (2) Decal Sets, "EMERGENCY EXIT", Black, Inside and Outside
47NJA	PAINT COLOR, BODY EXTERIOR 4421 School Bus Yellow
47NJM	PAINT FLASHER BACKGRD 0001 Canyon Black
47NJS	PAINT COLOR, BUMPER Rear, 0001 Canyon Black
47NKD	PAINT COLOR, ROOF 9219 Winter White, Beginning 5" Above Drip
47NKL	PAINT, RUB RAIL Flange to Flange
47NKM	PAINT COLOR, BODY INTERIOR 9384 Spring White
47NMG	OPERATING INSTR, REAR Decal, Inside Rear Emergency Door

Vehicle Specifications
2023 Electric CE S Bus (PB10E)

February 23, 2022

<u>Code</u>	<u>Description</u>
47NTE	LOGO, ROOF LINE Decal; Wing and Shield, First Body Section, Above Driver Window and Entrance Door Over Driver Window and Entrance Door
47NXW	DECAL, BUMPERS Yellow Numbers, Front and Rear
47PAR	BODY CERTIFICATION TAG Mylar Label, with Actual Tire Load Rating
47PCG	HANDLE, ASSIST Windshield Side Mounted, Left and Right, Body Color, with Certain Mirrors Only
47SBS	SUB FLOOR, PLYWOOD Conventional; B-C Exterior Grade, Less Sealed Edges, 5/8", 5 Ply, for 31'2", 31'11", 32'8", 33'5", 34'2", 34'11", 35'8" Body Lengths
47SPJ	ALPHA/NUMERIC DECAL GUIDE Quantity 081-90
48ACN	SEAT BELT, DRIVER, COLOR with Blaze Orange Seat Belt Webbing
48ANT	WINDOW, DRIVER Laminated, Clear
48APL	WINDOW, STOPS 12" Opening, Only with 78" Headroom
48ARU	WINDOW, SASH (20) 27" Sections, 9"x 23" Opening
48ASP	WINDOW, SASH +9 SECTIONS (2) 9" x 32 1/4" Opening
48BAH	WINDOW, E/E, LEFT (2) Vertical Hinge
48BJA	COLOR, WINDOW FRAME, PASS Passenger Window, Natural Aluminum Finish
48BKP	WINDOW, E/E, RIGHT (2) Vertical Hinge
48BUB	WINDOW, PASSENGER, TINT Conventional; 28% Light, Tempered Glass, 78" Headroom, with 34'11", 31'2", 31'11", 32'8", 33'5", 34'2", 35'8" Body Lengths
48CMY	UPHOLSTERY, DRIVER SEAT, COLOR 2-Tone Gray
48GHC	HEATER, DRIVER 90,000 BTU, with Defroster and without Rear Heat Duct
48NAT	FITTINGS, AIR SEAT for Driver Seat
48PAM	WINDSHIELD 3 Flat Pieces, 73% Light, with Band
48PAV	WHEEL POCKET COVER Plastic, ABS
48PAY	AISLE POSITION Center, for balanced seating
48PEW	FLOOR COVERING, COLOR Gray #766
48PJZ	FLOOR COVERING, TYPE {Koroseal} All Body Lengths
48PKM	FLOOR COVERING, TRIM {Koroseal} Plastic Base with PVC Cap
48PKS	FAN, DEFOG RIGHT CENTER 6.50" Diameter, Black, Mounted Over Windshield, 15" Right of Centerline, 2-Speed Switch in Panel
48PPS	ROOF VENT, FRONT Static
48PTT	ARM REST, DRIVER, RIGHT {National}
48PUT	NUTS, BELT MOUNTING Standard Nuts For Seat Belt Mounting
48PVB	UPHOLSTERY, DRIVER SEAT, STYLE Plain
48PWD	UPHOLSTERY, PASS SEATS, COLOR Gray, for Seats, Barriers and Head Bumpers
48PWZ	UPHOLSTERY, DRIVER SEAT, TYPE Fabric
48PXA	UPHOLSTERY, BARRIER, TYPE (1-2) Vinyl, 42 oz.
48RAE	BARRIER, CRASH, AFT ENTRY DOOR 39", 1 Leg

Vehicle Specifications
2023 Electric CE S Bus (PB10E)

February 23, 2022

<u>Code</u>	<u>Description</u>
48RAL	BARRIER, CRASH, AFT DRIVER 39", 1 Leg
48REP	PANEL, MODESTY, AFT OF DRIVER Mounted Under Barrier
48RET	PANEL, MODESTY, AFT ENTR DOOR Mounted Under Barrier
48RGE	HAND RAIL, ENTRANCE DOOR, FWD Stainless Steel; Curved
48RGR	HAND RAIL, ENTRANCE DOOR, AFT Stainless Steel, 4", Above Step
48RLX	CUSHION, SEAT 15" Depth
48RLZ	COMPARTMENT, HEATER for Webasto Scholastic Fuel Fired, Mounted Left Side Behind Front Wheel Pocket
48RRA	UPHOLSTERY, SEAT, STITCHING Single
48RTL	SEAT, TRACK, LT, 39", 2 LEG (3)
48RTS	SEAT, TRACK, RT, 39", 2 LEG (2)
48RUP	SEAT, TRACK, LT, 39", 4 LEG (9)
48RYZ	SEAT, TRACK, LT, 26", 4 LEG (01)
48SBG	UPHOLSTERY, PASS SEATS, TYPE Vinyl, 42 Ounce
48SYP	SEAT, TRACK, RT, 39", 4 LEG (11)
48TZK	SEAT, DRIVER {National Premium} Air Suspension with Suspension Skirt, Triple Chamber Adjustable Air Lumbar, Adjustable Cushion and Back Bolsters, 6 Position Front Cushion Adjuster, 3 Position Rear Cushion Adjuster, 6 to 23 Degree Back Recline
48USV	SEAT BACK, PASSENGER High Back
48UZN	ROOF HATCH, FRONT {Specialty Hybrid Adv H1975-025-191-0F} Emergency Exit with Outside Release, Alarm, English Decals
48UZT	ROOF HATCH, REAR {Specialty Hybrid Adv H1975-025-191-0F} Emergency Exit with Outside Release, Alarm, English Decals
48VVR	STEP TREADS {Koroseal} Pebble White Nosing Only, with Non-Metal Backing, used with Formed Treaded Steps
49AHV	LIGHT, STROBE, STOP SIGN, FRT In Lieu Of Flashing Lights Furnished with Stop Sign, Speciality
49AMD	SWITCH, DRIVER PANEL, TYPE Rocker
49AMJ	ALARM, BACKING {Ecco #575} 107 db
49AMT	CIRCUIT, PROTECTION Breakers, Manual Reset in Lieu of Fuses
49AMY	SWITCH, REAR DOOR BUZZER for Emergency Door
49ANH	SWITCH, MAGNETIC, DISCONNECT Master, Ignition Operated, All Body Circuits
49ANU	SOURCE, POWER 12 VDC, Mounted In Dash
49AUM	SWITCH, MASTER FLASHER Omit Master Flasher Switch, 8-Lamp System
49AWV	SPEAKERS AND WIRING (8) Flush Mounted In Light Bar
49BCL	FLASHER SYSTEM (8) Warning Lights, 8-Lamp System, Electronic Relay Flasher, Sequential Operation, Red Lights Activate after Amber Lights, with Road Speed Parameters
49BCR	LIGHT, EXTERIOR, CHECK Automatically Activates Lights for Pre Trip Inspection
49BEW	MIRROR, REAR VIEW, EXTERIOR {Mirror Lite Super Nickels} Black, Motorized Head, Heated

Vehicle Specifications
2023 Electric CE S Bus (PB10E)

February 23, 2022

<u>Code</u>	<u>Description</u>
49BMA	STOP ARM, FRONT {Specialty 2980} Air, 18" Octagon, Double Sided, 1/2" White Border, Hi Intensity Grade, Strobing LED Lights
49BUT	VISOR, INTERIOR, LEFT FRONT 6" x 30", Transparent, For Left Windshield, with Finger Hold Adjustment Knob
49BVE	MIRROR, CROSS VIEW, EXTERIOR (2) {Mirror Lite High Definition Busboy} Black
49BYT	LIGHTS, STOP (2) {Sound Off/OptiLuxx} and Tail; 7" Round LED, Red
49BYZ	LIGHTS, DIRECTIONAL, REAR (2) {Sound Off/OptiLuxx} LED, 7" Round Amber
49BZG	LIGHTS, BACK UP (2) {Sound Off/OptiLuxx} LED, 7" Round Clear
49CLM	RADIO, ENTERTAINMENT AM/FM/USB Input/Auxiliary Input, Includes Antenna and Cable, with Public Address System
49DAG	LIGHT, INDIC, WARNING LIGHTS LED Type; Red and Amber
49DBR	HOOD, WARNING LAMP (4) Black, 8-Lamp System, One Hood Above Two Lights
49EAX	LIGHTS, DIRECTIONAL, SIDE (4) {Sound Off/OptiLuxx} Rectangular LED Armored, 2 Each Side First Section Aft Entrance Door & Forward Rear Wheel Pocket
49ENR	VISOR, INTERIOR, DRIVER LEFT 10" X 30" for Driver's Window
49ESC	LIGHTS, DOME, DRIVER {Sound Off/OptiLuxx} (1) LED, Rectangular, Mounted in Light Bar in Ceiling, with Separate Switch
49EUB	KIT, FIRST AID Metal; 24 Unit, Spec State
49EVL	SWITCH, NOISE SUPPRESSION Actuator Legend States, "NOISE SUPP ", for Separate Solenoid, with Red Switch in Panel
49GBG	KIT, BODY FLUID Arizona, Mounted on the Bulkhead
49GBV	WINDSHIELD WIPERS (2) Cowl Mounted
49GDG	PADDING COMPART ABOVE DRIVER Window; Safety Equipment Compartment, with Cutout for Dome Light
49GDS	COMPARTMENT ABOVE DRIVER Left of the Driver
49GGE	FIRE EXTINGUISHER, DRIVER AREA 5 lb 2A-40BC Minimum, with Flexible Hose and Metal Nozzle
49GHN	REFLECTORS, REAR (2) 3", Red, Adhesive Back
49GHR	REFLECTORS, SIDE, REAR (2) 3", Red, Adhesive Back
49GHV	REFLECTORS, SIDE, FRONT (2) 3", Amber; Adhesive Back, 1 Aft Drivers Window Left, 1 Aft Entrance Door Right
49GHX	REFLECTORS, SIDE, INTERMEDIATE (2) 3" Amber, 1 Each Side, Below The Third Rub Rail From the Top, Adhesive Back
49GKL	SAFETY TRIANGLES 1 Kit; Warning Reflectors, Mounted on Floor Between Driver Seat and Drivers Crash Barrier/Stanchion
49GUK	FENDERS, RUBBER, REAR (2)
49GUX	MUD FLAPS, FRONT WHEELS (2) Rubber
49GVC	MUD FLAPS, REAR WHEELS (2) Rubber
49GWW	WINDSHIELD WASHER Kit; 6 Quart Capacity, Bottle
49JAK	TRACK, FLOOR LENGTHS 651"-700", Less Shoulder Track
49JAL	TRACK, COVER

Vehicle Specifications
2023 Electric CE S Bus (PB10E)

February 23, 2022

<u>Code</u>	<u>Description</u>
49JBG	TRACK, TYPE (BRAND) {OMNI L Track}
49JBP	LIGHTS, DOME {Sound Off/OptiLuxx} (07) LED, Rectangular Recessed Type, Mounted in Light Bar
49JBS	LIGHTS, CLUSTER {Sound Off/OptiLuxx} Oval, 4 Internal LEDs per Light; Amber Front and Red Rear
49JBU	LIGHT, ENTRY DOOR {Sound Off/OptiLuxx} LED; 4" Oval; Light Mounted in Skirt Behind Entrance Door, Wired To Step Light
49JBX	LIGHT, STEP {Sound Off/OptiLuxx} 4" Round LED, White, Wired to Ignition, Operated by Entrance Door
49JBY	LIGHTS, MARKER, FRONT & REAR (4) {Sound Off/OptiLuxx} LED, Armored, Slim-Line, (2) Amber Front and (2) Red Rear
49MRN	MIRROR, INSIDE 6" x 30" with Lever Lock
49MZV	LATCH, COMPARTMENT Locking, for Overhead Storage Compartment
49NGB	LIGHT, COMPARTMENT, ENGINE {Sound Off/OptiLuxx} LED 4" Oval; Activated with Parking Lights, with On/Off Switch, Includes Limit Switch that Allows Light to come on When Hood is Opened
49NGG	LIGHTS, TAIL, LICENSE PLATE (2) {Sound Off/OptiLuxx} 4" Round LED, Red, Includes Stop & Light Window, Includes Mounting Gasket
49NGJ	LIGHTS, WARNING (8) {Sound Off/OptiLuxx} (4) 7" Round Red Strobing LED and (4) 7" Round Amber Strobing LED, 2 Front, 2 Rear Each Color
49UAC	STATE OF OPERATION Arizona
49ZNE	LIGHTS, MARKER, SIDE, INTERMED {Sound Off/OptiLuxx} LED, Amber, Slim-Line, Armored, Intermediate, Centered, Required for Units 30 Foot or Longer
7382135443	(2) TIRE, FRONT 11R22.5 Load Range H ECOPLUS HS3+ (CONTINENTAL), 495 rev/mile, 75 MPH, All-Position
7382135443	(4) TIRE, REAR 11R22.5 Load Range H ECOPLUS HS3+ (CONTINENTAL), 495 rev/mile, 75 MPH, All-Position
OBD001	BODY PLAN, NON-SPECIAL NEEDS .RWC-638

Services Section:

40133	WARRANTY Standard for Electric School Bus Models, Effective with Vehicles Built October 1, 2020 or Later, CTS-3310
40RAM	SERVICES, TOWING {Navistar} Service Call to 60-Month/Unlimited Mileage to the Nearest IC Bus Dealer for Navistar Warrantable Failure as Contract Defined; Includes Engine Failure if Supplier Declines Tow Coverage & ESC Supplied thru Navistar; \$550 (USA) Maximum Benefit per Incident
49GVN	WARRANTY 5-Year, Limited

Body/Allied Equipment

<u>Code</u>	<u>Description</u>
<u>Goods Purchased</u>	
<u>Code</u>	<u>Description</u>

Turning Radius Summary
2023 Electric CE S Bus (PB10E)

February 23, 2022

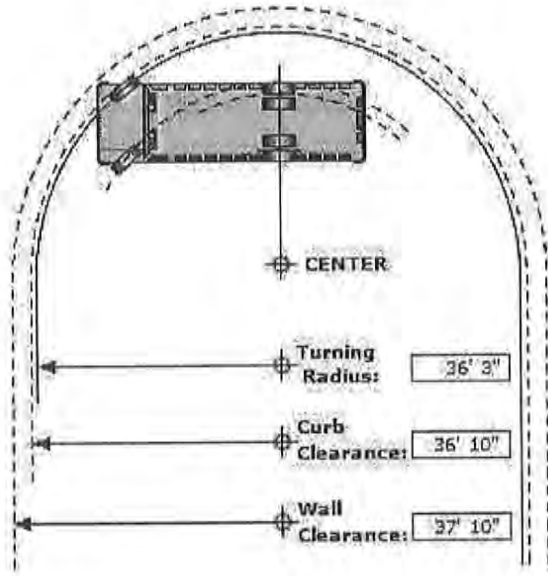

Series: INGB
 Model: PB10E
 Description: Electric CE S Bus
 Model Year: 2023

Calculation Factors

Wheelbase: 276
 Front Axle: 0002ASH
 Description: AXLE, FRONT NON-DRIVING, {Meritor MFS-10-122A} I-Beam Type, 10,000-lb Capacity
 Front Wheel: 0027DUW
 Description: WHEELS, FRONT, {Accuride 51408} DISC; 22.5x8.25 Rims, Powder Coat Steel, 2-Hand Hole, 10-Stud, 285.75mm BC, Hub-Piloted, Flanged Nut, with Steel Hubs
 Front Tire: 07382135443
 Description: TIRES, 11R22.5 Load Range H ECOPLUS HS3+ (CONTINENTAL), 495 rev/mile, 75 MPH, All-Position
 Steering Gear: 0005PRR
 Description: STEERING GEAR, {TRW (Ross) TAS66} Power

Turning Radius Statistics

General Information

Inside Turn Angle: 50 Degrees
 Radial Overhang: 19

Axle Information

KingPin Inclination: 6.25 Degrees
 KingPin Center: 69

Turning Radius - Curb View

C - Curb Contact Length: 15.95
 CI - Curb Clearance Increment: 6.14
 CR - Curb Clearance Radius: 36'10"
 CH - Curb Height: 6"
 TR - Turning Radius: 36'3"
 TW - Tire Width: 11.70

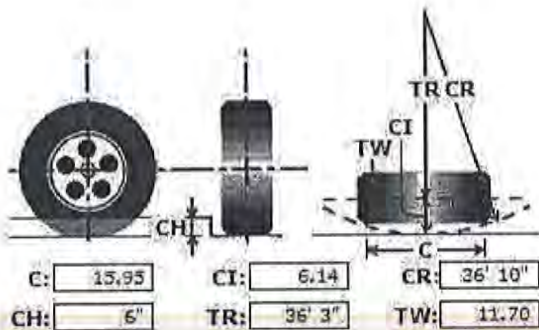

* All Measurements are in inches, unless otherwise specified.

This information is based on engineering information available at this time. Actual figures may vary. Navistar, Inc. cannot accept liability for consequences due to this variance.



Date: 3/10/23
Quote Valid Until:
Prepared By: TOM HARTMAN

Name:
Organization: EQUALIS GROUP
Address:
City, State ZIP:
Phone:

YEAR:	2024
MAKE:	IC
MODEL:	CE EV
CAPACITY:	44 PASS SPECIAL NEEDS
STOCK #'S:	RWCICCE-3

		\$ 508,000.00
INCLUDES 3 CAMERA SYSTEM AND DVR INCLUDES AC SYSTEM EV FREEBLOW		
TRADE BUS #:		Trade Total: \$ -
		Pre Tax Sub Total: \$ 508,000.00
		Sales Tax (): \$ -
Local Delivery Charge: 0		\$ -
		\$ -
TOTAL PRICE:		\$ 508,000.00

RWC ICE-3 EV Bus 4/2/22
Special Needs

June 30, 2022

Prepared For:
RWC International Ltd
TOM HARTMAN
2202 S Central Ave.
Phoenix, AZ 85004-2908
(602)307 - 1050
Reference ID: CE2608-217-44VE

Presented By:
RWC Group
Julie Shockley
600 North 75th Avenue
PHOENIX AZ 85043 -
(602)307-1050

Model Profile
2023 Electric CE S Bus (PB10E)

APPLICATION:	School Transportation, Special Needs
MISSION:	Requested GVWR: 30280. Calc. GVWR: 30280 Calc. Start / Grade Ability: 19.60% / 3.48% @ 55 MPH Calc. Geared Speed: 70.9 MPH
DIMENSION:	Wheelbase: 217.00, CA: N/A, Axle to Frame: 126.00
MOTOR, ELECTRIC, DRIVETRAIN:	{Dana TM4 SUMO MD HV2200-6P} 255kW Rated Power @ 1000 RPM, 2355 Nm Rated Torque @ 1000 RPM
AXLE, FRONT NON-DRIVING:	{Meritor MFS-10-122A} I-Beam Type, 10,000-lb Capacity
AXLE, REAR, SINGLE:	{Dana Spicer 21060SP} Single Reduction, Pinion Up, 21,000-lb Capacity, R Wheel Ends Gear Ratio: 5.57
TIRE, FRONT:	(2) 255/70R22.5 Load Range H AH37 (HANKOOK), 562 rev/mile, 75 MPH, All-Position
TIRE, REAR:	(4) 255/70R22.5 Load Range H AH37 (HANKOOK), 562 rev/mile, 75 MPH, All-Position
SUSPENSION, REAR, AIR, SINGLE:	{International IROS} 21,000-lb Capacity, 9.25" Ride Height, with Shock Absorbers
PAINT:	Cab schematic 272NB Location 1: 4421, School Bus Yellow (Std) Location 2: 4421, School Bus Yellow (Std) Chassis schematic N/A

Vehicle Specifications
2023 Electric CE S Bus (PB10E)

June 30, 2022

Code	Description
PB10E00	Base Chassis, Model Electric CE S Bus with 217.00 Wheelbase, N/A CA, and 126.00 Axle to Frame.
1570	TOW HOOK, FRONT (2) Frame Mounted
1CGL	FRAME RAILS Heat Treated Alloy Steel (120,000 PSI Yield); 10.125" x 3.062" x 0.312" (257.2mm x 77.8mm x 8.0mm); 480.1" (12195mm) Maximum OAL
1LLE	BUMPER, FRONT Contoured, Steel, Severe Duty
1LNT	CROSSING GATE, FRONT Omit Item
1SAL	CROSSMEMBER, REAR, AF (1)
1WHT	WHEELBASE RANGE 193" (490cm) Through and Including 217" (550cm)
1WRP	TOW HOOK, REAR (2) Mounted on Lower Rail Flange
2ASH	AXLE, FRONT NON-DRIVING {Meritor MFS-10-122A} I-Beam Type, 10,000-lb Capacity
3ADB	SUSPENSION, FRONT, SPRING Parabolic Taper Leaf, Shackle Type, 10,000-lb Capacity, with Shock Absorbers
4091	BRAKE SYSTEM, AIR Dual System for Straight Truck Applications
4AZS	AIR BRAKE ABS {Bendix AntiLock Brake System} 4-Channel (4 Sensor/4 Modulator) Electronic Stability Program, with Automatic Traction Control
4EBT	AIR DRYER {Bendix AD-IP} with Heater
4SPS	AIR COMPRESSOR {Quanxing} 10.6 CFM, for Electric Vehicle
4VLN	AIR TANK LOCATION (2) Mounted Outside Right Rail, Side by Side, Back of Stepwell, for Electric Vehicle
4WEA	PARKING BRAKE INTERLOCK Parking Brake Cannot be Released Until Ignition Switch is in "On" Position and Service Brake Pedal is Applied, Use with Air Brake Chassis Only
4WWX	DRAIN VALVE {Humphrey} (3) Air Operated, with Controls in Drivers Compartment, for Air Tanks
4WZT	GVWR LIMITATION FOR BUS with Air Brakes, Limited to 33,000-lbs Maximum to meet FMVSS 121 Requirements, for Conventional Bus
4XCJ	BRAKES, FRONT {Bendix Spicer ADB22X} Air Disc Type, Extended Service, Size 22.5", 23,000-lb Capacity
4XCK	BRAKES, REAR {Bendix Spicer ADB22X} Air Disc Type, Extended Service, Size 22.5", 26,000-lb Capacity per Axle
4XDV	BRAKE CHAMBERS, FRONT AXLE 14 SqIn, for Air Disc Brakes
4XDZ	BRAKE CHAMBERS, REAR AXLE 16/24 SqIn Spring Brake, Double Diaphragm, for Air Disc Brakes
5710	STEERING COLUMN Tilting and Telescoping
5CAL	STEERING WHEEL 2-Spoke, 18" Dia., Black
5PRR	STEERING GEAR {TRW (Ross) TAS66} Power
6DGL	DRIVELINE SYSTEM {Dana Spicer} Service Free SPL170, for 4x2/6x2
8000	ELECTRICAL SYSTEM 12-Volt, Standard Equipment
8MVY	BATTERY SYSTEM {Energys Odyssey 31-PC2150 AGM} Maintenance-Free, (2) AGM 12-Volt 2300CCA Total, Top Threaded Stud
8TLC	BATTERY PACK High Voltage, 210 kWh Total Capacity
8TTK	BATTERY BOX Steel, with Sliding Tray, 25.25" Wide, for Standard Batteries, 1-3 Battery Capacity, Mounted Left Side Behind Front Axle Perpendicular to Frame Rail

Vehicle Specifications
2023 Electric CE S Bus (PB10E)

June 30, 2022

<u>Code</u>	<u>Description</u>
8VBD	HORN, ELECTRIC (2) Trumpet Style, Mounted Above Right Frame Rail
8WPB	HEADLIGHTS Halogen, Composite Aero Design, with Daytime Running Lights
8WSU	CHARGING PORT Forward Location, for Electric Vehicle
	<u>Includes</u> : CHARGING PORT Forward Charging Port Located Right Side Aft of Entrance Door
8WUC	POWER CONVERTER HV Battery to 12V Battery, with Dual Converters, for Electric Vehicle
8WWJ	INDICATOR, LOW COOLANT LEVEL with Audible Alarm
8WXB	HEADLIGHT WARNING BUZZER Sounds When Head Light Switch is on and Ignition Switch is in "Off" Position
8XAH	CIRCUIT BREAKERS Manual-Reset (Main Panel) SAE Type III with Trip Indicators, Replaces All Fuses
8XNX	SOUND GENERATOR for Electric Vehicle
9WAB	HOOD TILT ASSIST {EASY TILT} Mechanical
9WAY	FRONT END Tilting, Fiberglass, with Three Piece Construction
10020	CHASSIS PAINT Full Chassis
10072	PAINT SCHEMATIC, PT-1 Two Tone, Design 272.
10788	PAINT TYPE Urethane, One or Two Colors, Other than Imron or International.
10AEP	FLEET HEALTH MONITOR REPORTING for 60 Months
10AET	ADVANCED PREVENTIVE MAINT for 60 Months
10AGC	COMMUNICATIONS MODULE Telematics Device; Includes Five Year Data Plan and International 360
10WHJ	SPECIAL ROUTING CONTROL To Bus Vehicle Modification Center
10WLM	SPECIAL ROUTING CONTROL WIFI to CBC for Kajeet Wi-Fi Installation; Contact CBC for Quote/Pricing
12703	ANTI-FREEZE Red, Extended Life Coolant; To -40 Degrees F/ -40 Degrees C, Freeze Protection
12AAB	MOTOR, ELECTRIC, DRIVETRAIN {Dana TM4 SUMO MD HV2200-6P} 255kW Rated Power @ 1000 RPM, 2355 Nm Rated Torque @ 1000 RPM
12VVN	CRUISE CONTROL Electronic
12VWH	GOVERNOR Electronic Road Speed Type; for Electronic Engines and Bus Models; with 55 MPH Default
12XCJ	RADIATOR Aluminum, 2-Row, Cross Flow, Four 12" E-Fan System, 595 SqIn Louvered, for Electric Vehicle
14AKR	AXLE, REAR, SINGLE {Dana Spicer 21060SP} Single Reduction, Pinion Up, 21,000-lb Capacity, R Wheel Ends . Gear Ratio: 5.57
14TBS	SUSPENSION, REAR, AIR, SINGLE {International IROS} 21,000-lb Capacity, 9.25" Ride Height, with Shock Absorbers
14WAW	FLAT FLOOR EFFECTS for Air Suspension; with Conventional Bus Models
16010	COWL Flat Back
16HCV	GAUGE CLUSTER English with English Electronic Speedometer, for Electric Vehicle
16VCD	DASH INSULATOR
27DUW	WHEELS, FRONT {Accuride 51408} DISC; 22.5x8.25 Rims, Powder Coat Steel, 2-Hand Hole, 10-Stud, 285.75mm BC, Hub-Piloted, Flanged Nut, with Steel Hubs
28DUW	WHEELS, REAR {Accuride 51408} DUAL DISC; 22.5x8.25 Rims, Powder Coat Steel, 2-Hand Hole, 10-Stud, 285.75mm BC, Hub-Piloted, Flanged Nut, with Steel Hubs

Vehicle Specifications
2023 Electric CE S Bus (PB10E)

June 30, 2022

Code	Description
47AEU	BODY, BUS Conventional; 78" Headroom, 26'8" Body Length, +9 Section Front and Rear, 54 Passenger, 217/218 WB
47AJC	BODY TAG, METAL Capacity to Include the Total Number of Passengers
47APR	HEADLINER, BODY Conventional; 25'11"-34'11" Body Length, Perforated Full Length with Sound Insulation Full Length
47APW	FASTENERS, HEADLINER Rivets
47ARH	BOWS, ROOF 14 ga., One Piece Construction
47ARP	LIGHT BARS Plastic
47ASZ	SKIRT, BODY Conventional, 20", 16ga., 25'2", 25'11", 26'8", 27'5" Body Length
47AUR	TIE DOWNS, BODY Grade 8 Bolts, Every Body Section
47AXR	RUB RAILS, BODY (4) Conventional; Steel, 25'2", 25'11", 26'8", 27'5" Body Length, Includes Snow Rail
47AYB	BODY, REAR Includes Emergency Door
47AZC	SIDE SHEET, BODY, EXTERIOR Conventional, 16ga., Smooth, 25'2", 25'11", 26'8", 27'5", Body Length
47AZK	FLOOR, BODY Flat
47AZX	RAILS, WRAP-AROUND, FLOOR At Floor Level To Rear Door Post
47AZZ	RAILS, WRAP-AROUND Just Below Window Line
47BAK	BUMPER, REAR Painted, 12" High, 3/16" Thick
47BAR	SUPPORTS, REAR BUMPER Bolted to Frame
47BBH	LINING, SIDE INTERIOR, LOWER Embossed Steel, Clear Coated
47BBZ	SEALER Extra; Sidewall to Floor, In Wheel Pocket Area, and Rear Wall to Floor
47BLE	STEP, FRONT ENTRANCE DOOR 25 3/4" Depth; 14ga Steel, Formed Treads, Naviflex Finish
47DAJ	COVER, REAR DOOR INSIDE HANDLE Partial Coverage
47DAK	FASTENERS, REAR DOOR Bolts and Nutserts, Rear Door To Body
47DBP	DOOR, ENTRANCE, FRONT Air, Outward Opening, with Split Pane Glass
47DCW	HANDLE, EXTERIOR, LIFT DOOR Single Door, Yellow
47DDE	HANDLE, ASSIST, ENTRANCE DOOR Outside Entrance
47DDH	HOLD BACK, REAR DOOR Stationary, No Cables, with Plastic Cover
47DDR	LATCH, LIFT DOOR Single, Three Point Slide Bar
47DDU	LATCH, REAR DOOR One Point Slide Bar, Cam Operated, with One Inch Stroke
47DEK	LOCK, REAR DOOR with Ignition Starter Interlock
47DEV	LOCK, SINGLE LIFT DOOR with Ignition Starter Interlock
47DEY	HANDLE, EXTERIOR, REAR Emergency Door; Yellow
47DNK	SWITCH, LOCATION Steering Wheel; Includes Master Flasher, Flasher On/Off, Red Override, and Door Control
47DWP	DOOR, LIFT Single, 43" x 69.79", Mounted Aft of Rear Wheel Pocket, with 78" Headroom
47DWU	KEYS ALIKE, BATTERY BOX , 545 Keys

Vehicle Specifications
2023 Electric CE S Bus (PB10E)

June 30, 2022

<u>Code</u>	<u>Description</u>
47DWW	KEYS ALIKE, LOCKS Entrance Door, 545 Keys
47EBD	LOCK, BATTERY COMPARTMENT Standard Location
47EBM	HOLD DOWN, BATTERY For (2) Standard Size Batteries
47EXK	LOCK, ENTRANCE DOOR Integrated Manual Control in Door, with Key
47KDC	MONITOR, POST TRIP INSPECTION {Leave No Student Behind} Accessory Controlled, with Push Button Alarm Disable at Rear of Bus in Light Bar Prompts Driver to Walk to Back of Bus to Disable Alarm
47LAB	NOISE REDUCTION, DRIVER FLOOR Insulation Covering Complete Driver Floor Area
47LAR	NOISE REDUCTION, ROOF BOW Conventional; Insulation, 25'2", 25'11", 26'8", 27'5" Body Lengths
47LAU	INSULATION, ROOF/SIDES/BULKHEAD 1.5"
47MBA	UNDERCOAT, BODY Fire Resistant, Water Based, TT-C-730 Spec
47MJR	LETTERS, DOOR, REAR Decals; "EMERGENCY DOOR", 2" Black Letters Inside and Outside
47MKT	DECAL, HANDICAP (2) 6" x 6", Rear Door Between Top and Bottom Glass, and on Right Front Below Windshield
47MNM	LETTERS, BATTERY COMPARTMENT (01) Decal; "Battery"; 2" Black Letters, Centered on Standard Battery Box
47MNT	ARROW, RR DOOR, INSIDE Decal; Red, .75" Stroke, Indicating Handle Direction
47MNV	ARROW, RR DOOR, OUTSIDE Decal; Black .75" Stroke, Indicating Handle Direction
47MPD	LETTERS, SCHOOL BUS FRONT/REAR Decal; "SCHOOL BUS"; with 8" Black Reflective Letters, Reflexite V82, On Front and Rear Cap
47MSA	STRIPING, PERIMETER, REAR Emergency Door, Reflexite 1" Yellow Reflective
47MSE	STRIPING, REAR END Reflexite 2" Yellow
47MSJ	STRIPING, ROOF HATCH, FRONT Reflexite Decal, Perimeter, 1" Yellow
47MSS	STRIPING, SEATLINE Reflexite V82, 2" Yellow
47MTY	WIRING DIAGRAM Schematic, Electrical
47MVA	LETTERS, HEADER Decal; "WATCH YOUR STEP", 1" Black, Above Windshield
47MVC	LETTERS, STEPWELL Decal, "WATCH YOUR STEP", 2.5" Black, Behind Door on Step Riser
47NAB	PAINT COLOR, RUB RAILS 0001 Canyon Black
47NGT	PAINT HOOD TOP 4422 Yellow, Non-Reflecting
47NGW	SEAL, RUB RAILS Top Edge, All Rails
47NJA	PAINT COLOR, BODY EXTERIOR 4421 School Bus Yellow
47NJM	PAINT FLASHER BACKGRD 0001 Canyon Black
47NJS	PAINT COLOR, BUMPER Rear, 0001 Canyon Black
47NKD	PAINT COLOR, ROOF 9219 Winter White, Beginning 5" Above Drip
47NKL	PAINT, RUB RAIL Flange to Flange
47NKM	PAINT COLOR, BODY INTERIOR 9384 Spring White
47NMG	OPERATING INSTR, REAR Decal, Inside Rear Emergency Door
47NNA	LETTERS, E/E WINDOW, LEFT (01) Decal Set, "EMERGENCY EXIT", Black Inside and Outside

Vehicle Specifications
2023 Electric CE S Bus (PB10E)

June 30, 2022

<u>Code</u>	<u>Description</u>
47NNY	LETTERS, E/E WINDOW, RIGHT (01) Decal Set, "EMERGENCY EXIT", Black, Inside and Outside
47NRN	STRIPING, E/E WINDOW, LEFT (01) Perimeter, Reflexite V82, 1" Yellow
47NRT	STRIPING, E/E WINDOW, RIGHT (01) Perimeter, Reflexite V82, 1" Yellow
47NTE	LOGO, ROOF LINE Decal; Wing and Shield, First Body Section, Above Driver Window and Entrance Door Over Driver Window and Entrance Door
47NXW	DECAL, BUMPERS Yellow Numbers, Front and Rear
47PAR	BODY CERTIFICATION TAG Mylar Label, with Actual Tire Load Rating
47PCG	HANDLE, ASSIST Windshield Side Mounted, Left and Right, Body Color, with Certain Mirrors Only
47SBP	SUB FLOOR, PLYWOOD Conventional; B-C Exterior Grade, Less Sealed Edges, 5/8", 5 Ply, for 25'2", 25'11", 26'8" or 27'5" Body Lengths
47SPJ	ALPHA/NUMERIC DECAL GUIDE Quantity 081-90
48ACN	SEAT BELT, DRIVER, COLOR with Blaze Orange Seat Belt Webbing
48ANT	WINDOW, DRIVER Laminated, Clear
48APL	WINDOW, STOPS 12" Opening, Only with 78" Headroom
48ARG	WINDOW, SASH (11) 27" Sections, 9"x 23" Opening
48ASR	WINDOW, SASH +9 SECTIONS (3) 9" x 32 1/4" Opening
48BAG	WINDOW, E/E, LEFT (01) Vertical Hinge
48BJA	COLOR, WINDOW FRAME, PASS Passenger Window, Natural Aluminum Finish
48BKN	WINDOW, E/E, RIGHT (01) Vertical Hinge
48BTX	WINDOW, PASSENGER, TINT Conventional; 28% Light, Tempered Glass, 78" Headroom, with 25'2", 25'11", 26'8", 27'5" Body Lengths
48CER	HEATER, PASSENGER {UWE P90} Convection Type, with 26'8" Body Length
48CMY	UPHOLSTERY, DRIVER SEAT, COLOR 2-Tone Gray
48CXZ	AIR CONDITIONER, BODY IC Air, 120,000 BTU, Evaporators ProAir Front & Rear Flush Mounted, Condensers ProAir Skirt Mounted, Electric Compressors, with ProAir Control System
48GHC	HEATER, DRIVER 90,000 BTU, with Defroster and without Rear Heat Duct
48GRW	SEAT, CHILD, RT, TRK, 39", 6 LEG {IMMI Seats} (01) High Back, with Child Restraint System and Non-Retractable Maroon/Blue/Brown Lap belts
48NAT	FITTINGS, AIR SEAT for Driver Seat
48PAM	WINDSHIELD 3 Flat Pieces, 73% Light, with Band
48PAY	AISLE POSITION Center, for balanced seating
48PEW	FLOOR COVERING, COLOR Gray #766
48PJR	FLOOR COVERING, TRIM Aluminum
48PJZ	FLOOR COVERING, TYPE {Koroseal} All Body Lengths
48PKR	FAN, DEFOG LEFT CENTER 6.50" Diameter, Black, Mounted Left of Center Post, 2-Speed Switch in Panel
48PMS	HEATER, STEPWELL 50,000 BTU
48PPS	ROOF VENT, FRONT Static

Vehicle Specifications
2023 Electric CE S Bus (PB10E)

June 30, 2022

<u>Code</u>	<u>Description</u>
48PTT	ARM REST, DRIVER, RIGHT {National}
48PUT	NUTS, BELT MOUNTING Standard Nuts For Seat Belt Mounting
48PVB	UPHOLSTERY, DRIVER SEAT, STYLE Plain
48PWD	UPHOLSTERY, PASS SEATS, COLOR Gray, for Seats, Barriers and Head Bumpers
48PWZ	UPHOLSTERY, DRIVER SEAT, TYPE Fabric
48PXA	UPHOLSTERY, BARRIER, TYPE (1-2) Vinyl, 42 oz.
48RAE	BARRIER, CRASH, AFT ENTRY DOOR 39", 1 Leg
48RAL	BARRIER, CRASH, AFT DRIVER 39", 1 Leg
48RET	PANEL, MODESTY, AFT ENTR DOOR Mounted Under Barrier
48RGE	HAND RAIL, ENTRANCE DOOR, FWD Stainless Steel; Curved
48RGR	HAND RAIL, ENTRANCE DOOR, AFT Stainless Steel, 4", Above Step
48RHV	PANEL, MODESTY, AFT OF DRIVER Mounted Under Barrier, with Holes for Air Circulation
48RLX	CUSHION, SEAT 15" Depth
48RRA	UPHOLSTERY, SEAT, STITCHING Single
48RTV	SEAT, TRACK, LT, 30", 4 LEG (2)
48RUL	SEAT, TRACK, LT, 39", 4 LEG (6)
48RUT	SEAT, TRACK, RT, 30", 4 LEG (2)
48RVC	SEAT, TRACK, RT, 39", 4 LEG (4)
48SBG	UPHOLSTERY, PASS SEATS, TYPE Vinyl, 42 Ounce
48TZK	SEAT, DRIVER {National Premium} Air Suspension with Suspension Skirt, Triple Chamber Adjustable Air Lumbar, Adjustable Cushion and Back Bolsters, 6 Position Front Cushion Adjuster, 3 Position Rear Cushion Adjuster, 6 to 23 Degree Back Recline
48USV	SEAT BACK, PASSENGER High Back
48UZN	ROOF HATCH, FRONT {Specialty Hybrid Adv H1975-025-191-0F} Emergency Exit with Outside Release, Alarm, English Decals
48VKV	SEAT BELT, DUAL Non-Retractable, Maroon/Brown, 04 Seats
48VPL	SEAT BELT, TRIPLE Non-Retractable, Maroon/Blue/Brown, 10 Sets
48VVR	STEP TREADS {Koroseal} Pebble White Nosing Only, with Non-Metal Backing, used with Formed Treaded Steps
48XXH	SEAT, CHILD, LT, 39", 2 LEG {BTI Seating System} (01) High Back, with Child Restraint System and Non-Retractable Maroon/Blue/Brown Lap Belts 7.5" on the Buckle Side
49AHV	LIGHT, STROBE, STOP SIGN, FRT In Lieu Of Flashing Lights Furnished with Stop Sign, Speciality
49AMD	SWITCH, DRIVER PANEL, TYPE Rocker
49AMJ	ALARM, BACKING {Ecco #575} 107 dB
49AMT	CIRCUIT, PROTECTION Breakers, Manual Reset in Lieu of Fuses
49AMY	SWITCH, REAR DOOR BUZZER for Emergency Door
49ANH	SWITCH, MAGNETIC, DISCONNECT Master, Ignition Operated, All Body Circuits

Vehicle Specifications
2023 Electric CE S Bus (PB10E)

June 30, 2022

Code	Description
49ANU	SOURCE, POWER 12 VDC, Mounted In Dash
49ATK	LIGHT, INDIC, LIFT DOOR Green; Flashing, Located in Driver Area
49AUM	SWITCH, MASTER FLASHER Omit Master Flasher Switch, 8-Lamp System
49AWU	SPEAKERS AND WIRING (6) Flush Mounted in Light Bar
49BCL	FLASHER SYSTEM (8) Warning Lights, 8-Lamp System, Electronic Relay Flasher, Sequential Operation, Red Lights Activate after Amber Lights, with Road Speed Parameters
49BCR	LIGHT, EXTERIOR, CHECK Automatically Activates Lights for Pre Trip Inspection
49BEW	MIRROR, REAR VIEW, EXTERIOR {Mirror Lite Super Nickels} Black, Motorized Head, Heated
49BMA	STOP ARM, FRONT {Specialty 2980} Air, 18" Octagon, Double Sided, 1/2" White Border, Hi Intensity Grade, Strobing LED Lights
49BTL	ANTENNA REI # 210073, Flexible Rubber Antenna with Swivel Base and 160" Cable
49BUT	VISOR, INTERIOR, LEFT FRONT 6" x 30", Transparent, For Left Windshield, with Finger Hold Adjustment Knob
49BVE	MIRROR, CROSS VIEW, EXTERIOR (2) {Mirror Lite High Definition Busboy} Black
49BWM	LIFT, WHEELCHAIR {Braun Model NL919IB} Gen-2, Power Pack Mounted Rear of Lift, 800-lb Capacity
49BYL	LIGHTS, DOME {Sound Off/OptiLuxx} (05) LED, Rectangular Recessed Type, Mounted in Light Bar
49BYT	LIGHTS, STOP (2) {Sound Off/OptiLuxx} and Tail; 7" Round LED, Red
49BYZ	LIGHTS, DIRECTIONAL, REAR (2) {Sound Off/OptiLuxx} LED, 7" Round Amber
49BZA	LIGHT, LIFT DOOR {Sound Off/OptiLuxx} 4" Oval 3 White LED, Flush Mounted, Exterior, 2 Below Door in Skirt and 1 Half Way up Left Side of Lift Door Opening
49BZC	LIGHT, LIFT DOOR, INTERIOR {Sound Off/OptiLuxx} Above Lift Door, Rectangular LED, with Door Operated Switch (Functionality May Be Included in Existing Dome Light)
49BZG	LIGHTS, BACK UP (2) {Sound Off/OptiLuxx} LED, 7" Round Clear
49CLM	RADIO, ENTERTAINMENT AM/FM/USB Input/Auxiliary Input, Includes Antenna and Cable, with Public Address System
49DAG	LIGHT, INDIC, WARNING LIGHTS LED Type; Red and Amber
49DBR	HOOD, WARNING LAMP (4) Black, 8-Lamp System, One Hood Above Two Lights
49EGC	MIRROR, INSIDE 6" x 30", Clear Safety Glass, Metal Back, Round Corners
49ENR	VISOR, INTERIOR, DRIVER LEFT 10" X 30" for Driver's Window
49ESC	LIGHTS, DOME, DRIVER {Sound Off/OptiLuxx} (1) LED, Rectangular, Mounted in Light Bar in Ceiling, with Separate Switch
49EUB	KIT, FIRST AID Metal; 24 Unit, Spec State
49EVL	SWITCH, NOISE SUPPRESSION Actuator Legend States, "NOISE SUPP ", for Separate Solenoid, with Red Switch in Panel
49GBG	KIT, BODY FLUID Arizona, Mounted on the Bulkhead
49GBV	WINDSHIELD WIPERS (2) Cowl Mounted
49GDG	PADDING COMPART ABOVE DRIVER Window; Safety Equipment Compartment, with Cutout for Dome Light
49GDS	COMPARTMENT ABOVE DRIVER Left of the Driver

Vehicle Specifications
2023 Electric CE S Bus (PB10E)

June 30, 2022

Code	Description
49GEH	SAFETY TRIANGLES Warning Reflectors, Mounted on Drivers Barrier 9.5" Above Floor
49GGE	FIRE EXTINGUISHER, DRIVER AREA 5 lb 2A-40BC Minimum, with Flexible Hose and Metal Nozzle
49GHN	REFLECTORS, REAR (2) 3", Red, Adhesive Back
49GHR	REFLECTORS, SIDE, REAR (2) 3", Red, Adhesive Back
49GHV	REFLECTORS, SIDE, FRONT (2) 3", Amber; Adhesive Back, 1 Aft Drivers Window Left, 1 Aft Entrance Door Right
49GHX	REFLECTORS, SIDE, INTERMEDIATE (2) 3" Amber, 1 Each Side, Below The Third Rub Rail From the Top, Adhesive Back
49GMM	INTERLOCK, LIFT for FMVSS Wheel Chair Interlock Requirements; Key Off, Lift Door Must be Open before Lift can be Activated, w/ Key in "On or Accessory" Position, Park Brake Must be Applied, Transmission in Neutral, Lift Door Must be Open Before Lift Can be Activated, w/ Automatic or Precision Transmissions
49GUB	CUTTER, SEAT BELT {TIE TECH Safecut} for Cutting Seat Belts
49GUK	FENDERS, RUBBER, REAR (2)
49GVA	MUD FLAPS, FRONT WHEELS (2) Anti-Sail and Anti-Spray
49GVC	MUD FLAPS, REAR WHEELS (2) Rubber
49GWW	WINDSHIELD WASHER Kit; 6 Quart Capacity, Bottle
49HAL	STORAGE COMPARTMENT, BELTS (5) for Q-Straint Wheelchair Belts, Mounted to Wall
49HGG	TRACK, FLOOR LENGTHS 401"-450", with Full Shoulder Track
49HHD	TIE DOWN, TRACK (05) Retractable
49JAL	TRACK, COVER
49JBG	TRACK, TYPE (BRAND) {OMNI L Track}
49JBS	LIGHTS, CLUSTER {Sound Off/OptiLuxx} Oval, 4 Internal LEDs per Light; Amber Front and Red Rear
49JBU	LIGHT, ENTRY DOOR {Sound Off/OptiLuxx} LED; 4" Oval; Light Mounted in Skirt Behind Entrance Door, Wired To Step Light
49JBX	LIGHT, STEP {Sound Off/OptiLuxx} 4" Round LED, White, Wired to Ignition, Operated by Entrance Door
49JBY	LIGHTS, MARKER, FRONT & REAR (4) {Sound Off/OptiLuxx} LED, Armored, Slim-Line, (2) Amber Front and (2) Red Rear
49MJX	TIE DOWN, TRACK TYPE {QRT Q-8107-A1-L2} Retractable, with Track Fittings on Shoulder Belt
49MZV	LATCH, COMPARTMENT Locking, for Overhead Storage Compartment
49NGB	LIGHT, COMPARTMENT, ENGINE {Sound Off/OptiLuxx} LED 4" Oval; Activated with Parking Lights, with On/Off Switch, Includes Limit Switch that Allows Light to come on When Hood is Opened
49NGG	LIGHTS, TAIL, LICENSE PLATE (2) {Sound Off/OptiLuxx} 4" Round LED, Red, Includes Stop & Light Window, Includes Mounting Gasket
49NGJ	LIGHTS, WARNING (8) {Sound Off/OptiLuxx} (4) 7" Round Red Strobing LED and (4) 7" Round Amber Strobing LED, 2 Front, 2 Rear Each Color
49PSY	LIGHTS, DIRECTIONAL, SIDE {Sound Off/OptiLuxx} (2) Slim-Line LED Armored, Amber, (1) Each Side First Section Aft Entrance Door
49UAC	STATE OF OPERATION Arizona
49ZNE	LIGHTS, MARKER, SIDE, INTERMED {Sound Off/OptiLuxx} LED, Amber, Slim-Line, Armored, Intermediate, Centered, Required for Units 30 Foot or Longer

Vehicle Specifications
2023 Electric CE S Bus (PB10E)

June 30, 2022

<u>Code</u>	<u>Description</u>
7752525809	(2) TIRE, FRONT 255/70R22.5 Load Range H AH37 (HANKOOK), 562 rev/mile, 75 MPH, All-Position
7752525809	(4) TIRE, REAR 255/70R22.5 Load Range H AH37 (HANKOOK), 562 rev/mile, 75 MPH, All-Position
OBD001	BODY PLAN, SPECIAL NEEDS RWC-637

Services Section:

40133	WARRANTY Standard for Electric School Bus Models, Effective with Vehicles Built October 1, 2020 or Later, CTS-3310
40RAM	SERVICES, TOWING {Navistar} Service Call to 60-Month/Unlimited Mileage to the Nearest IC Bus Dealer for Navistar Warrantable Failure as Contract Defined; Includes Engine Failure if Supplier Declines Tow Coverage & ESC Supplied thru Navistar; \$550 (USA) Maximum Benefit per Incident
49GVN	WARRANTY 5-Year, Limited

Body/Allied Equipment

<u>Code</u>	<u>Description</u>
Goods Purchased	
<u>Code</u>	<u>Description</u>

Date: 3/10/23
Quote Valid Until:
Prepared By: TOM HARTMAN



Name:
Organization: EQUALIS GROUP
Address:
City, State ZIP:
Phone:

YEAR:	2024
MAKE:	GM
MODEL:	COLLINS BUS EV
CAPACITY:	24
STOCK #'S:	RWCGM-1

		INCLUDES 3 CAMERA SYSTEM AND DVR INCLUDES AC SYSTEM EV FREEBLOW	\$ 450,000.00
TRADE BUS #:		Trade Total:	\$ -
		Pre Tax Sub Total:	\$ 450,000.00
		Sales Tax ():	\$ -
Local Delivery Charge:		0	\$ -
			\$ -
		TOTAL PRICE:	\$ 450,000.00

Collins Type A EV 24 passenger RWCGM-1



SRO-3786	^ SEAT LH 39D 3PT/ICS MED GRY FB	3
SRO-3787	^ SEAT RH 39D 3PT/ICS MED GRY FB	4
COL-20220801	• PRICE SCHEDULE COL 08/01/2022	1
100-1-21-12	• SPEC FMVSS SCHOOL BUS >10K	1
110-DE516-15	CORE DRW ELEV FLR 5SEC+16	1
115-1516-00-20	TRIM BODY 5SEC+16	1
12323G6614Y321	* CU/23/D159/6.6G/14200/Y/ACTC	1
200-000015-12	AC OEM CHASSIS ONLY/ NO OEM AC	1
210-23-00-20	* BATTERY OEM LOCATION FORD ELEC	1
230-200-15	BUMPER 10" GALV EXH UNDER/SD	1
233-220-21	* BRACE BUMPER DE/H 516 ELEC	1
236-1602-22	* CHAS FUEL PREP E W HTR LEM	1
238-61-516-1-20	* CHAS MDL PREP FD E516/E516WR E	1
250-311-12	DOOR ENTRANCE DE TEMP	1
260-5-16	DOOR ENTRANCE CONTROL ELEC	1
265-212-22	DOOR REAR EGRESS ALUM RH HINGE	1
270-01-12	DOOR REAR HINGE 1PC STAINLESS	1
280-10-13	DOOR REAR LATCH 1PT	1
294-02-12	* ELEC FRAMEWORK CHEV SCHOOL BUS	1
300-31-12	DOOR REAR BUZZER - ADDITIONAL	1
300-51-12	BACK-UP ALARM	1
300-72-12	SWITCH HTR/FAN SHUTDOWN W/CHAS	1
305-00000-20	CHILD ALERT NONE	1
310-0000-20	BACKUP CAMERA NONE	1
320-516-230-20	* EXHST FORD 516 STD ELE	1
330-104-12	ENDCAPS DE W/WARNING LIGHT	1
332-223-22	EXT PANELS REAR DE STL W/DR	1
334-516-21-12	EXT PANELS ROOF DRW 516 ALUM	1
336-516-402-14	EXT PANELS SIDE DE 516 STEEL	1
338-2516-22-14	SKIRT DE 516 STEEL NO CONDENSER	1
339-222-20-14	EXT SKIRT NOBOX DE 500/516 STL	1
340-03-12	MUD FLAPS REAR DE	1
345-12-12	* DRIVER ENTRANCE STEP CHEV BLK	1
350-516-21-2-12	FLOOR COVER GRY DRW CENTER 516	1
355-02-22-12	STEP TREAD DH/E PEB BACKED GRY	1
360-516-22-12	FLOOR SUBFLOOR DH/E516 5/8 PLY	1
400-28-20	* HEATER 60K FLR MOUNT FORD ELE	1
420-516-20-14	INT PANELS LOWER EMBOSS E516	1
422-030-15	INT PANELS REAR DH/DE NO AC	1
430-516-101-13	INT PNLS UPPR DRW 516 PERF ALM	1
440-01-12	GRABRAIL LH ENTR 42IN BARR MNT	1
440-02-12	GRABRAIL RH ENTR 30IN	1
440-03-12	MIRROR INTERIOR 6X16 FLAT	1

440-13-12	PERMIT HOLDER 6X9 PLASTIC	2
440-90-12	ROOF AND WALL BOW INSULATION	1
445-01-20	APPLICATION INTERIOR PERMASAFE	1
450-01-12	STOP/TAIL/TURN 4IN FLUSH LED	1
460-02-12	STOP/TAIL 7IN RED LED	1
470-01-12	CLEARANCE LIGHTS LED	1
472-02-12	LIGHTS DOME BODY BAT+SWITCH	1
474-03-12	LIGHTS DOME DRIVER BAT+SWITCH	1
480-03-12	TURN SIGNAL REAR 7IN AMBER	1
490-01-12	LIGHTS REVERSE 4IN FLUSH LED	1
494-03-12	LIGHTS STEPWELL HEADLTS+DOOR	1
510-03-12	WARNING LAMPS 8LT LED SURF MNT	1
520-07-2-12	WARN SYS 8LT SEQ OVRD CNCL BAT	1
530-02-12	VISORS 8LT	1
540-05-12	TURN SIGNAL MIDBODY AMBER LED	1
540-10-19	LIGHT ADA BELOW ENTRY DOOR LED	1
555-03-12	SWITCH DIMMER LIGHTS ON PANEL	1
555-05-12	DOME REAR LT SEPARATE SW	1
565-12-1110-12	* MIRROR EXT GM DRW REM HT BL	1
580-05-202-12	PADDING PKG DE GRY FB	1
590-11-202-12	PAD ABOVE DRIVER GRY FB	1
600-12-002-14	* PAINT BODY EXT CHEV DH/DE YELL	1
620-32-13	BLACK BORDER WARN LT 3IN VERT	1
640-01-12	PREWIRE FOR 2 WAY RADIO	1
640-02-12	SPEAKER EXTERNAL PA ONLY	1
640-04-12	PAGE W/MICROPHONE ONLY 2SPK	1
640-06-12	SPEAKERS 2 INTERNAL OEM RADIO	2
650-51620999-12	RUBRAIL FLR LVL DH/DE516 BLK	1
652-51620999-12	RUBRAIL SEAT LVL DH/DE516 BLK	1
654-51620999-12	RUBRAIL WNDW LVL DH/DE516 BLK	1
656-00000000-12	• RUBRAIL NONE AT SKIRT LEVEL	1
660-12-12	TRIANGLE WARNING REFLECTORS 3	1
660-22-12	FIRE EXT 5LB 3A 40BC FRONT MNT	1
660-31-12	SEAT BELT CUTTER	1
670-027-12	BODY FLUID KIT #208-027 WA	1
680-045-12	FIRST AID KIT #203-045 MULTI	1
690-3-01-39-202	BARRIER LH 39D GRAY FB	1
691-3-12	• BARRIER SPACING LH 3PAX FMVSS	1
700-3-01-39-202	BARRIER RH 39D GRAY FB	1
701-0-12	• BARRIER SPACING RH NONE	1
711-28-12	• SEAT SPACING LH 28IN HIP/KNEE	3
721-28-12	• SEAT SPACING RH 28IN HIP/KNEE	4
730-01-14	INSTALL SEAT TO FLOOR BOLT/NUT	7
750-3-1-39-15	KICKPANEL 39" DRW HSM LH BARRI	1
760-01-12	LETTERBELT 5IN DECAL	1
423605-688	EVERETT SCHOOL DISTRICT NO. 002	2

760-22-002-12	REFLECT TAPE 2IN REAR DH/DE Y	1
760-53-12	SIGN UNLAWFUL TO PASS REFL WA	1
770-02-12	SIGN ENDCAP "SCHOOL BUS" REFL	1
780-101-14	* SIGNAGE ID COLLINS ALT FUEL	1
790-19-12	INFO LABEL "MAX DES CAP"	1
800-07-12	EMERG DOOR INT & EXT BLK LETTR	1
830-110-21	* CROSS ARM SPEC POLY BLD CHEVY	1
840-05-12	STOP ARM FRNT STROB PLAST 6100	1
860-02-12	STATIC ROOF VENT W/CONTROL	1
870-01-001-12	HATCH TRAN MODEL 1975 1IN W	1
925-01-12	* WINDOW TRANSITION CHEV TEMP	1
950-113-12	WNDWS REAR BODY TEMP AS3	1
960-13-12	WNDW REAR DOOR LOWER TEMP AS3	1
970-13-12	WNDW REAR DOOR UPPER TEMP AS3	1
980-213-12	WINDOW SASH H/E TEMP TINT	10
985-02-12	UNDERCOATING FULL BODY	1
986-03-14	WARRANTY BODY 5-3-3 YR EXT LIM	1

Date: 3/10/23
 Quote Valid Until:
 Prepared By: TOM HARTMAN



Name:
 Organization: EQUALIS GROUP
 Address:
 City, State ZIP:
 Phone:

YEAR:	2024
MAKE:	GM
MODEL:	COLLINS BUS EV
CAPACITY:	18 PLUS 1 WC
STOCK #'S:	RWCGM-2

		\$ 458,000.00
INCLUDES 3 CAMERA SYSTEM AND DVR INCLUDES AC SYSTEM EV FREEBLOW		
TRADE BUS #:		Trade Total: \$ -
		Pre Tax Sub Total: \$ 458,000.00
		Sales Tax (): \$ -
Local Delivery Charge: 0		\$ -
		\$ -
TOTAL PRICE:		\$ 458,000.00

Collins Type A Special Needs RWGGM-2 18 plus 1



SRO-3786	^ SEAT LH 39D LAP	3
SRO-3787	^ SEAT RH 39D LAP	4
COL-20220801	* 18 PLUS 1 WHEELCHAIR	1
100-1-21-12	* SPEC FMVSS SCHOOL BUS >10K	1
110-DE516-15	CORE DRW ELEV FLR 5SEC+16	1
115-1516-00-20	TRIM BODY 5SEC+16	1
12323G6614Y321	* CU/23/D159/6.6G/14200/Y/ACTC	1
200-000015-12	AC OEM CHASSIS ONLY/ NO OEM AC	1
210-23-00-20	* BATTERY OEM LOCATION FORD ELEC	1
230-200-15	BUMPER 10" GALV EXH UNDER/SD	1
233-220-21	* BRACE BUMPER DE/H 516 ELEC	1
236-1602-22	* CHAS FUEL PREP E W HTR LEM	1
238-61-516-1-20	* CHAS MDL PREP FD E516/E516WR E	1
250-311-12	DOOR ENTRANCE DE TEMP	1
260-5-16	DOOR ENTRANCE CONTROL ELEC	1
265-212-22	DOOR REAR EGRESS ALUM RH HINGE	1
270-01-12	DOOR REAR HINGE 1PC STAINLESS	1
280-10-13	DOOR REAR LATCH 1PT	1
294-02-12	* ELEC FRAMEWORK CHEV SCHOOL BUS	1
300-31-12	DOOR REAR BUZZER - ADDITIONAL	1
300-51-12	BACK-UP ALARM	1
300-72-12	SWITCH HTR/FAN SHUTDOWN W/CHAS	1
305-00000-20	CHILD ALERT NONE	1
310-0000-20	BACKUP CAMERA NONE	1
320-516-230-20	* EXHST FORD 516 STD ELE	1
330-104-12	ENDCAPS DE W/WARNING LIGHT	1
332-223-22	EXT PANELS REAR DE STL W/DR	1
334-516-21-12	EXT PANELS ROOF DRW 516 ALUM	1
336-516-402-14	EXT PANELS SIDE DE 516 STEEL	1
338-2516-22-14	SKIRT DE 516 STEEL NO CONDENSER	1
339-222-20-14	EXT SKIRT NOBOX DE 500/516 STL	1
340-03-12	MUD FLAPS REAR DE	1
345-12-12	* DRIVER ENTRANCE STEP CHEV BLK	1
350-516-21-2-12	FLOOR COVER GRY DRW CENTER 516	1
355-02-22-12	STEP TREAD DH/E PEB BACKED GRY	1
360-516-22-12	FLOOR SUBFLOOR DH/E516 5/8 PLY	1
400-28-20	* HEATER 60K FLR MOUNT FORD ELE	1
420-516-20-14	INT PANELS LOWER EMBOSS E516	1
422-030-15	INT PANELS REAR DH/DE NO AC	1
430-516-101-13	INT PNLS UPPR DRW 516 PERF ALM	1
440-01-12	GRABRAIL LH ENTR 42IN BARR MNT	1
440-02-12	GRABRAIL RH ENTR 30IN	1
440-03-12	MIRROR INTERIOR 6X16 FLAT	1

440-13-12	PERMIT HOLDER 6X9 PLASTIC	2
440-90-12	ROOF AND WALL BOW INSULATION	1
445-01-20	APPLICATION INTERIOR PERMASAFE	1
450-01-12	STOP/TAIL/TURN 4IN FLUSH LED	1
460-02-12	STOP/TAIL 7IN RED LED	1
470-01-12	CLEARANCE LIGHTS LED	1
472-02-12	LIGHTS DOME BODY BAT+SWITCH	1
474-03-12	LIGHTS DOME DRIVER BAT+SWITCH	1
480-03-12	TURN SIGNAL REAR 7IN AMBER	1
490-01-12	LIGHTS REVERSE 4IN FLUSH LED	1
494-03-12	LIGHTS STEPWELL HEADLTS+DOOR	1
510-03-12	WARNING LAMPS 8LT LED SURF MNT	1
520-07-2-12	WARN SYS 8LT SEQ OVRD CNCL BAT	1
530-02-12	VISORS 8LT	1
540-05-12	TURN SIGNAL MIDBODY AMBER LED	1
540-10-19	LIGHT ADA BELOW ENTRY DOOR LED	1
555-03-12	SWITCH DIMMER LIGHTS ON PANEL	1
555-05-12	DOME REAR LT SEPARATE SW	1
565-12-1110-12	* MIRROR EXT GM DRW REM HT BL	1
580-05-202-12	PADDING PKG DE GRY FB	1
590-11-202-12	PAD ABOVE DRIVER GRY FB	1
600-12-002-14	* PAINT BODY EXT CHEV DH/DE YELL	1
620-32-13	BLACK BORDER WARN LT 3IN VERT	1
640-01-12	PREWIRE FOR 2 WAY RADIO	1
640-02-12	SPEAKER EXTERNAL PA ONLY	1
640-04-12	PAGE W/MICROPHONE ONLY 2SPK	1
640-06-12	SPEAKERS 2 INTERNAL OEM RADIO	2
650-51620999-12	RUBRAIL FLR LVL DH/DE516 BLK	1
652-51620999-12	RUBRAIL SEAT LVL DH/DE516 BLK	1
654-51620999-12	RUBRAIL WNDW LVL DH/DE516 BLK	1
656-00000000-12	* RUBRAIL NONE AT SKIRT LEVEL	1
660-12-12	TRIANGLE WARNING REFLECTORS 3	1
660-22-12	FIRE EXT 5LB 3A 40BC FRONT MNT	1
660-31-12	SEAT BELT CUTTER	1
670-027-12	BODY FLUID KIT #208-027 WA	1
680-045-12	FIRST AID KIT #203-045 MULTI	1
690-3-01-39-202	BARRIER LH 39D GRAY FB	1
691-3-12	* BARRIER SPACING LH 3PAX FMVSS	1
700-3-01-39-202	BARRIER RH 39D GRAY FB	1
701-0-12	* BARRIER SPACING RH NONE	1
711-28-12	* SEAT SPACING LH 28IN HIP/KNEE	3
721-28-12	* SEAT SPACING RH 28IN HIP/KNEE	4
730-01-14	INSTALL SEAT TO FLOOR BOLT/NUT	7
750-3-1-39-15	KICKPANEL 39" DRW HSM LH BARRI	1
760-01-12	LETTERBELT 5IN DECAL	1
423605-688	EVERETT SCHOOL DISTRICT NO. 002	2

760-22-002-12	REFLECT TAPE 2IN REAR DH/DE Y	1
760-53-12	SIGN UNLAWFUL TO PASS REFL WA	1
770-02-12	SIGN ENDCAP "SCHOOL BUS" REFL	1
780-101-14	* SIGNAGE ID COLLINS ALT FUEL	1
790-19-12	INFO LABEL "MAX DES CAP"	1
800-07-12	EMERG DOOR INT & EXT BLK LETTR	1
830-110-21	* CROSS ARM SPEC POLY BLD CHEVY	1
840-05-12	STOP ARM FRNT STROB PLAST 6100	1
860-02-12	STATIC ROOF VENT W/CONTROL	1
870-01-001-12	HATCH TRAN MODEL 1975 1IN W	1
925-01-12	* WINDOW TRANSITION CHEV TEMP	1
950-113-12	WNDWS REAR BODY TEMP AS3	1
960-13-12	WNDW REAR DOOR LOWER TEMP AS3	1
970-13-12	WNDW REAR DOOR UPPER TEMP AS3	1
980-213-12	WINDOW SASH H/E TEMP TINT	10
985-02-12	UNDERCOATING FULL BODY	1
986-03-14	WARRANTY BODY 5-3-3 YR EXT LIM	1
986-03-14	BRAUN LIFT	1

Date: 3/10/23
Quote Valid Until:
Prepared By: TOM HARTMAN



Name:
Organization: EQUALIS GROUP
Address:
City, State ZIP:
Phone:

YEAR:	2024
MAKE:	IC
MODEL:	CE CUMMINS DIESEL
CAPACITY:	83
STOCK #'S:	RWCICCED-1

INCLUDES 3 CAMERA SYSTEM AND DVR INCLUDES AC SYSTEM EV FREEBLOW		\$ 225,000.00
TRADE BUS #:		Trade Total: \$ -
		Pre Tax Sub Total: \$ 225,000.00
		Sales Tax (): \$ -
		Local Delivery Charge: 0 \$ -
		\$ -
TOTAL PRICE:		\$ 225,000.00

RWC I(CED) - 83 pass Diesel Cummins

September 09, 2022

Prepared For:
RWC International Ltd
TOM HARTMAN
2202 S Central Ave.
Phoenix, AZ 85004-2908
(602)307 - 1050
Reference ID: CE3508-276-83*

Presented By:
RWC Group
Julie Shockley
600 North 75th Avenue
PHOENIX AZ 85043 -
(602)307-1050

Model Profile
2024 INTEGRATED CE S BUS (PB105)

APPLICATION:	School Transportation
MISSION:	Requested GVWR: 31000. Calc. GVWR: 31000 Calc. Start / Grade Ability: 23.21% / 1.92% @ 55 MPH Calc. Geared Speed: 92.5 MPH
DIMENSION:	Wheelbase: 276.00, CA: N/A, Axle to Frame: 176.00
ENGINE, DIESEL:	{Cummins B6.7 260} EPA 2021, 260HP @ 2400 RPM, 660 lb-ft Torque @ 1600 RPM, 2600 RPM Governed Speed, 260 Peak HP (Max), School Bus Only
TRANSMISSION, AUTOMATIC:	{Allison 2500 PTS} 6th Generation Controls, Wide Ratio, 6-Speed with Double Overdrive, Less PTO Provision, Less Retarder, with 33,000-lb GVW and GCW Max, School Bus
CLUTCH:	Omit Item (Clutch & Control)
AXLE, FRONT NON-DRIVING:	{Meritor MFS-10-122A} I-Beam Type, 10,000-lb Capacity
AXLE, REAR, SINGLE:	{Dana Spicer S140} Single Reduction, 21,000-lb Capacity, 190 Wheel Ends Gear Ratio: 5.29
TIRE, FRONT:	(2) 11R22.5 Load Range H HSR2 (CONTINENTAL), 498 rev/mile, 75 MPH, All-Position
TIRE, REAR:	(4) 11R22.5 Load Range H HSR2 (CONTINENTAL), 498 rev/mile, 75 MPH, All-Position
SUSPENSION, REAR, AIR, SINGLE:	{International IROS} 21,000-lb Capacity, 9.25" Ride Height, with Shock Absorbers
PAINT:	Cab schematic 101NB Location 1: 4421, School Bus Yellow (Std) Location 2: 4422, School Bus Yellow Non Reflective (Nrf) Chassis schematic N/A

Vehicle Specifications
2024 INTEGRATED CE S BUS (PB105)

September 09, 2022

<u>Code</u>	<u>Description</u>
PB10500	Base Chassis, Model INTEGRATED CE S BUS with 276.00 Wheelbase, N/A CA, and 176.00 Axle to Frame.
1570	TOW HOOK, FRONT (2) Frame Mounted
1CAC	FRAME RAILS High Strength Low Alloy Steel (50,000 PSI Yield); 10.125" x 3.062" x 0.312" (257.2mm x 77.8mm x 8.0mm); 489.2" (12425mm) Maximum OAL <u>Includes</u> : CHASSIS PAINT Chassis Painted Prior to Body Mounting : FRAME RAILS All holes Laser Aligned and Machine Punched, Powder Coated Prior to Full Assembly, Assembled in Fixture using "Grade 8" Bolts : FRAME REINFORCEMENT, SPECIAL 3.30" x 1.80" x 0.312" x 31.50" Inverted "L" in Front Shock Absorber Mounting Area
1LLE	BUMPER, FRONT Contoured, Steel, Severe Duty <u>Includes</u> : BUMPER, FRONT THICKNESS 1/4 Inch
1LNT	CROSSING GATE, FRONT Omit Item <u>Includes</u> : CROSSING GATE, FRONT Matches Contour of Bumper
1SAM	CROSSMEMBER, REAR, AF (2)
1WJE	WHEELBASE RANGE 276" (700cm) Only
2ASH	AXLE, FRONT NON-DRIVING {Meritor MFS-10-122A} I-Beam Type, 10,000-lb Capacity <u>Includes</u> : AXLE, FRONT SQUARING to Plus or Minus .015 Inch, using a Special Fixture to Assure Parallelism of Springs <u>Notes</u> : The following features should be considered when calculating Front GAWR: Front Axles; Front Suspension; Brake System; Brakes, Front Air Cam; Wheels; Tires.
3ADB	SUSPENSION, FRONT, SPRING Parabolic Taper Leaf, Shackle Type, 10,000-lb Capacity, with Shock Absorbers <u>Includes</u> : SPRING PINS Bolt and Nut Type : SPRING PINS Rubber Bushings, Maintenance-Free <u>Notes</u> : The following features should be considered when calculating Front GAWR: Front Axles; Front Suspension; Brake System; Brakes, Front Air Cam; Wheels; Tires.
4091	BRAKE SYSTEM, AIR Dual System for Straight Truck Applications <u>Includes</u> : BRAKE LINES Color and Size Coded Nylon : DRAIN VALVE Twist-Type : GAUGE, AIR PRESSURE (2) Air 1 and Air 2 Gauges; Located in Instrument Cluster : PARKING BRAKE CONTROL Yellow Knob, Located on Instrument Panel : PARKING BRAKE VALVE For Truck : QUICK RELEASE VALVE On Rear Axle for Spring Brake Release: 1 for 4x2, 2 for 6x4 : SPRING BRAKE MODULATOR VALVE R-7 for 4x2, SR-7 with relay valve for 6x4/8x6 <u>Notes</u> : Rear Axle is Limited to 19,000-LB GAWR with Code 04091 BRAKE SYSTEM, AIR and Code 04NDC BRAKES, REAR, AIR CAM Regardless of Axle/Suspension Ordered : Rear Axle is Limited to 20,000-LB GAWR with Code 04092 BRAKE SYSTEM, AIR and Code 04NCW BRAKES, REAR, AIR CAM Regardless of Axle/Suspension Ordered

Vehicle Specifications
2024 INTEGRATED CE S BUS (PB105)

September 09, 2022

<u>Code</u>	<u>Description</u>
4AZS	AIR BRAKE ABS {Bendix AntiLock Brake System} 4-Channel (4 Sensor/4 Modulator) Electronic Stability Program, with Automatic Traction Control
4EBS	AIR DRYER {Bendix AD-9} with Heater
4EXP	BRAKE CHAMBERS, FRONT AXLE {Bendix} 20 SqiIn
4EXU	BRAKE CHAMBERS, REAR AXLE {Bendix EverSure} 30/30 SqiIn Spring Brake
4GBM	BRAKE, PARKING Manual Push-Pull Pneumatic Parking Brake
4LAG	SLACK ADJUSTERS, FRONT {Gunite} Automatic
4LGG	SLACK ADJUSTERS, REAR {Gunite} Automatic
4SPA	AIR COMPRESSOR {Cummins} 18.7 CFM
4VCY	AIR TANK LOCATION (1) Mounted Left Side to Provide Clearance for Larger Body Builder Supplied Battery Box
4WWX	DRAIN VALVE {Humphrey} (3) Air Operated, with Controls in Drivers Compartment, for Air Tanks
4WZT	GVWR LIMITATION FOR BUS with Air Brakes, Limited to 33,000-lbs Maximum to meet FMVSS 121 Requirements, for Conventional Bus
4XDP	BRAKES, FRONT {Meritor 16.5X5 Q-PLUS CAST} Air S-Cam Type, Cast Spider, Fabricated Shoe, Double Anchor Pin, Size 16.5" X 5", 14,700-lb Capacity
4XDR	BRAKES, REAR {Meritor 16.5X7 Q-PLUS CAST} Air S-Cam Type, Cast Spider, Fabricated Shoe, Double Anchor Pin, Size 16.5" X 7", 23,000-lb Capacity per Axle
5710	STEERING COLUMN Tilting and Telescoping
5CAL	STEERING WHEEL 2-Spoke, 18" Dia., Black
5PRR	STEERING GEAR {TRW (Ross) TAS66} Power
6DGA	DRIVELINE SYSTEM {Dana Spicer} SPL100, for 4x2/6x2
7BMK	EXHAUST SYSTEM Horizontal Aftertreatment System, Frame Mounted Under Right Rail, for Single Long Horizontal Tail Pipe
7WBL	TAIL PIPE (1) Horizontal, Long, Exits Left Side Through Bumper
8000	ELECTRICAL SYSTEM 12-Volt, Standard Equipment
	<u>Includes</u>
	: HAZARD SWITCH Push On/Push Off, Located on Top of Steering Column Cover
	: HEADLIGHT DIMMER SWITCH Integral with Turn Signal Lever
	: MISCELLANEOUS FEATURES Modular, Loom Protected, Grommets in all Applicable Body Openings, Assembled in Computer Assisted Fixture which Verifies Continuity and Correct Assembly Prior to Installation
	: PARKING LIGHT Integral with Front Turn Signal and Rear Tail Light
	: STARTER SWITCH Electric, Key Operated
	: TURN SIGNAL FLASHER
	: TURN SIGNAL SWITCH Self-Cancelling with Lane Change Feature
	: TURN SIGNALS, FRONT Includes Reflectors; Flush Mounted
	: WINDSHIELD WIPER SWITCH 2-Speed with Wash and Intermittent Feature (5 Pre-Set Delays), Integral with Turn Signal Lever
	: WIRING, CHASSIS Color Coded and Continuously Numbered
8GXK	ALTERNATOR {Leece-Neville BLP4006HN} Brushless, 12 Volt, 325 Amp Capacity, Pad Mount, with Remote Sense
8MSG	BATTERY SYSTEM {Fleetrite} Maintenance-Free, (3) 12-Volt 1980CCA Total, Top Threaded Stud

Vehicle Specifications
2024 INTEGRATED CE S BUS (PB105)

September 09, 2022

<u>Code</u>	<u>Description</u>
8TTK	BATTERY BOX Steel, with Sliding Tray, 25.25" Wide, for Standard Batteries, 1-3 Battery Capacity, Mounted Left Side Behind Front Axle Perpendicular to Frame Rail
8TUT	COLLISION MITIGATION SYSTEM Omit
8VBC	HORN, ELECTRIC (2) Trumpet Style, Mounted Above Left Frame Rail
8WPB	HEADLIGHTS Halogen, Composite Aero Design, with Daytime Running Lights
8WTK	STARTING MOTOR {Delco Remy 38MT Type 300} 12 Volt, Less Thermal Over-Crank Protection
8WWJ	INDICATOR, LOW COOLANT LEVEL with Audible Alarm
8WXB	HEADLIGHT WARNING BUZZER Sounds When Head Light Switch is on and Ignition Switch is in "Off" Position
8XAH	CIRCUIT BREAKERS Manual-Reset (Main Panel) SAE Type III with Trip Indicators, Replaces All Fuses
9AAE	LOGOS EXTERIOR, ENGINE Badges
9WAB	HOOD TILT ASSIST {EASY TILT} Mechanical
9WAY	FRONT END Tilting, Fiberglass, with Three Piece Construction
	<u>Includes</u>
	: AIR INTAKE SYSTEM Integrated Pre-Cleaning System to Enhance Air Filter Life
	: GRILLE Removable; Fiberglass Painted Hood Color
	: SPLASH SHIELD Integral with Front End Assembly
10020	CHASSIS PAINT Full Chassis
10063	PAINT SCHEMATIC, PT-1 Two Tone, Design 101 for Non-Reflecting Schoolbus Hood
10661	PAINT, NON-REFLECTING Non-Reflecting Paint
10788	PAINT TYPE Urethane, One or Two Colors, Other than Imron or International.
10XAK	PROMOTIONAL PACKAGE 7 Year Unlimited Miles/km Warranty, Limited Time Program for Allison 2500 Series Transmission on School and Commercial Buses (Supplied directly through Allison)
11001	CLUTCH Omit Item (Clutch & Control)
12703	ANTI-FREEZE Red, Extended Life Coolant; To -40 Degrees F/ -40 Degrees C, Freeze Protection
12ERU	ENGINE, DIESEL {Cummins B6.7 260} EPA 2021, 260HP @ 2400 RPM, 660 lb-ft Torque @ 1600 RPM, 2600 RPM Governed Speed, 260 Peak HP (Max), School Bus Only
12TSY	FAN DRIVE {Borg-Warner SA85} Viscous Type, Screw On
	<u>Includes</u>
	: FAN Nylon
12UGN	THROTTLE, HAND CONTROL Electronic
	<u>Notes</u>
	: Cruise Control Switches Mounted on Steering Wheel are Non-Illuminated.
12UYE	RADIATOR Aluminum, 2-Row, Cross Flow, Over Under System, 717 SqIn Louvered, with 313 SqIn Charge Air Cooler, Includes In-Tank Oil Cooler
	<u>Includes</u>
	: DEAERATION SYSTEM with Surge Tank
	: HOSE CLAMPS, RADIATOR HOSES Gates Shrink Band Type; Thermoplastic Coolant Hose Clamps
	: RADIATOR HOSES Premium, Rubber
12VBR	AIR CLEANER with Service Protection Element
	<u>Includes</u>

Vehicle Specifications
2024 INTEGRATED CE S BUS (PB105)

September 09, 2022

<u>Code</u>	<u>Description</u>
12VJB	: GAUGE, AIR CLEANER RESTRICTION Air Cleaner Mounted EMISSION, CALENDAR YEAR {Cummins B6.7} EPA, OBD and GHG Certified for Calendar Year 2022
12VVN	CRUISE CONTROL Electronic <u>Notes</u> : Cruise Control Switches Mounted on Steering Wheel are Non-Illuminated.
12VWH	GOVERNOR Electronic Road Speed Type; for Electronic Engines and Bus Models; with 55 MPH Default
12VYV	IDLE MANAGEMENT SYSTEM Ramp Engine Speed with Air Condition On, in Neutral and Parking Brake Set, Accommodation Package
12WAE	HOSE CLAMPS, RADIATOR HOSES Constant Torque, for Engine Hoses 1.0" I.D. and Over
12WSY	BLOCK HEATER, ENGINE {Phillips} 120V/750W, for Cummins ISB/B6.7 Engines
12WZE	CARB IDLE COMPLIANCE Federal, Does Not Comply with California Clean Air Idle Regulations
12XCS	CARB EMISSION WARR COMPLIANCE Federal, Does Not Comply with CARB Emission Warranty
13BBP	TRANSMISSION, AUTOMATIC {Allison 2500 PTS} 6th Generation Controls, Wide Ratio, 6-Speed with Double Overdrive, Less PTO Provision, Less Retarder, with 33,000-lb GVW and GCW Max, School Bus
13WLN	TRANSMISSION OIL Synthetic; 20 thru 28 Pints
13WVW	NEUTRAL AT STOP OMIT
13WYY	SHIFT CONTROL PARAMETERS {Allison} 1000 or 2000 Series Transmissions, Performance Programming
14AKC	AXLE, REAR, SINGLE {Dana Spicer S140} Single Reduction, 21,000-lb Capacity, 190 Wheel Ends . Gear Ratio: 5.29
14TBS	SUSPENSION, REAR, AIR, SINGLE {International IROS} 21,000-lb Capacity, 9.25" Ride Height, with Shock Absorbers <u>Notes</u> : The following features should be considered when calculating Rear GAWR: Rear Axles; Rear Suspension; Brake System; Brakes, Rear Air Cam; Brake Shoes, Rear; Special Rating, GAWR; Wheels; Tires.
15SJT	FUEL TANK Top Draw, Steel, Rectangular, 100 US Gal (379L), Includes Protective Cage, with Low Profile Fuel Filler Assembly and Vent Hosing, Mounted Between Frame Rails and Behind Rear Axle
15WEP	DEF TANK 16.5 US Gal (62.5L) Capacity, Frame Mounted Outside Right Rail, Behind 0 Bow
16010	COWL Flat Back
16HBA	GAUGE CLUSTER English with English Electronic Speedometer <u>Includes</u> : GAUGE CLUSTER (5) Engine Oil Pressure (Electronic), Water Temperature (Electronic), Fuel (Electronic), Tachometer (Electronic), Voltmeter : ODOMETER DISPLAY, Miles, Trip Miles, Engine Hours, Trip Hours, Fault Code Readout : WARNING SYSTEM Low Fuel, Low Oil Pressure, High Engine Coolant Temp, and Low Battery Voltage (Visual and Audible)
16HGH	GAUGE, OIL TEMP, AUTO TRANS for Allison Transmission
16HHE	GAUGE, AIR CLEANER RESTRICTION {Filter-Minder} with Black Bezel, Mounted in Instrument Panel
16HKT	IP CLUSTER DISPLAY On Board Diagnostics Display of Fault Codes in Gauge Cluster
16HLJ	GAUGE, DEF FLUID LEVEL
16VCD	DASH INSULATOR

Vehicle Specifications
2024 INTEGRATED CE S BUS (PB105)

September 09, 2022

Code	Description
27DUW	WHEELS, FRONT {Accuride 51408} DISC; 22.5x8.25 Rims, Powder Coat Steel, 2-Hand Hole, 10-Stud, 285.75mm BC, Hub-Piloted, Flanged Nut, with Steel Hubs
28DUW	WHEELS, REAR {Accuride 51408} DUAL DISC; 22.5x8.25 Rims, Powder Coat Steel, 2-Hand Hole, 10-Stud, 285.75mm BC, Hub-Piloted, Flanged Nut, with Steel Hubs
47AJC	BODY TAG, METAL Capacity to Include the Total Number of Passengers
47APR	HEADLINER, BODY Conventional; 25'11"-35'08" Body Length, Perforated Full Length with Sound Insulation Full Length
47APW	FASTENERS, HEADLINER Rivets
47ARH	BOWS, ROOF 14 ga., One Piece Construction <u>Includes</u> : BOWS, ROOF Positioned Floor Line to Floor Line, Threaded Through Roof Strainers and Drip Rail
47ARP	LIGHT BARS Plastic
47ATB	SKIRT, BODY Conventional, 20", 16ga., 31'2", 31'11", 32'8", 33'5", 34'2", 34'11", 35'8" Body Lengths <u>Includes</u> : SKIRT, BODY Extra Smooth Steel Supported by Floor Gussets
47AUR	TIE DOWNS, BODY Grade 8 Bolts, Every Body Section <u>Includes</u> : TIE DOWNS, BODY with Formed Tab that Fits into Floor Structure to Prevent Turning
47AVL	BODY, BUS Conventional; 78" Headroom, 35'8" Body Length, +9 Section Front and Rear, 83 Passenger, 276 WB
47AXT	RUB RAILS, BODY (4) Conventional; Steel, 31'2", 31'11", 32'8", 33'5", 34'2", 34'11", 35'8" Body Lengths, Includes Snow Rail <u>Includes</u> : RUB RAILS Full Length, Primer Coated (Both Sides), Attached to Body without Cuts or Splices
47AYB	BODY, REAR Includes Emergency Door <u>Includes</u> : DOOR, REAR EMERGENCY with Concealed Hinges : HEADER BUMPER Padded, Mounted Over Rear Door; Upholstered to Match Passenger Seat Color
47AZE	SIDE SHEET, BODY, EXTERIOR Conventional, 16ga., Smooth, 31'2", 31'11", 32'8", 33'5", 34'2", 34'11", 35'8" Body Lengths
47AZL	FLOOR, BODY with Wheel Wells
47AZX	RAILS, WRAP-AROUND, FLOOR At Floor Level To Rear Door Post
47AZZ	RAILS, WRAP-AROUND Just Below Window Line
47BAK	BUMPER, REAR Painted, 12" High, 3/16" Thick
47BAR	SUPPORTS, REAR BUMPER Bolted to Frame
47BAW	TOW HOOK, LEFT REAR (01)
47BAX	TOW HOOK, RIGHT REAR (01)
47BBH	LINING, SIDE INTERIOR, LOWER Embossed Steel, Clear Coated
47BBZ	SEALER Extra; Sidewall to Floor, In Wheel Pocket Area, and Rear Wall to Floor
47BLD	STEP, FRONT ENTRANCE DOOR 27 1/4" Depth; 14ga Steel, Formed Treads, Naviflex Finish

Vehicle Specifications
2024 INTEGRATED CE S BUS (PB105)

September 09, 2022

<u>Code</u>	<u>Description</u>
47DAJ	COVER, REAR DOOR INSIDE HANDLE Partial Coverage
47DAK	FASTENERS, REAR DOOR Bolts and Nutserts, Rear Door To Body
47DBP	DOOR, ENTRANCE, FRONT Air, Outward Opening, with Split Pane Glass
47DDE	HANDLE, ASSIST, ENTRANCE DOOR Outside Entrance
47DDH	HOLD BACK, REAR DOOR Stationary, No Cables, with Plastic Cover
47DDU	LATCH, REAR DOOR One Point Slide Bar, Cam Operated, with One Inch Stroke
47DEK	LOCK, REAR DOOR with Ignition Starter Interlock
47DEY	HANDLE, EXTERIOR, REAR Emergency Door; Yellow
47DNK	SWITCH, LOCATION Steering Wheel; Includes Master Flasher, Flasher On/Off, Red Override, and Door Control
	<u>Includes</u> : SWITCH, STEERING WHEEL, LIGHT Includes Illuminated Switches
47DWV	KEYS ALIKE, LOCKS Entrance Door, 545 Keys
47EBM	HOLD DOWN, BATTERY For (2) Standard Size Batteries
47ETG	COMPARTMENT, LUGGAGE, RT MID 66" X 24" X 22"
	<u>Includes</u> : HINGES Rubber : LATCH, T-HANDLE, LOCKING Stainless Steel
47EXK	LOCK, ENTRANCE DOOR Integrated Manual Control in Door, with Key
47KDC	MONITOR, POST TRIP INSPECTION {Leave No Student Behind} Accessory Controlled, with Push Button Alarm Disable at Rear of Bus in Light Bar Prompts Driver to Walk to Back of Bus to Disable Alarm
47LAB	NOISE REDUCTION, DRIVER FLOOR Insulation Covering Complete Driver Floor Area
47LAT	NOISE REDUCTION, ROOF BOW Conventional; Insulation, 31'2", 31'11", 32'8", 33'5", 34'2", 34'11", 35'8" Body Lengths
47LAU	INSULATION, ROOF/SIDES/BULKHEAD 1.5"
47MBA	UNDERCOAT, BODY Fire Resistant, Water Based, TT-C-730 Spec
	<u>Includes</u> : UNDERCOATING Performed Before and After Mounting on Chassis
47MJR	LETTERS, DOOR, REAR Decals; "EMERGENCY DOOR", 2" Black Letters Inside and Outside
47MNM	LETTERS, BATTERY COMPARTMENT (01) Decal; "Battery"; 2" Black Letters, Centered on Standard Battery Box
47MNV	ARROW, RR DOOR, OUTSIDE Decal; Black .75" Stroke, Indicating Handle Direction
47MPD	LETTERS, SCHOOL BUS FRONT/REAR Decal; "SCHOOL BUS"; with 8" Black Reflective Letters On Front and Rear Cap
47MRN	STRIPING, E/E WINDOW, LEFT (02) Perimeter, 1" Yellow
47MRU	LETTERS, E/E WINDOW, LEFT (2) Decal Sets, "EMERGENCY EXIT", Black Inside and Outside
47MSA	STRIPING, PERIMETER, REAR Emergency Door, 1" Yellow Reflective
47MSE	STRIPING, REAR END 2" Yellow
47MSJ	STRIPING, ROOF HATCH, FRONT Decal, Perimeter, 1" Yellow

Vehicle Specifications
2024 INTEGRATED CE S BUS (PB105)

September 09, 2022

<u>Code</u>	<u>Description</u>
47MSK	STRIPING, ROOF HATCH, REAR Decal, Perimeter, 1" Yellow
47MSS	STRIPING, SEATLINE 2" Yellow
47MTY	WIRING DIAGRAM Schematic, Electrical
	<u>Includes</u> : ACCESS PANEL for Wiring Diagram Schematic Located on Body Exterior; Below Driver Window
47MUP	STRIPING, E/E WINDOW, RIGHT (02) Perimeter, 1" Yellow
47MVA	LETTERS, HEADER Decal; "WATCH YOUR STEP", 1" Black, Above Windshield
47MVC	LETTERS, STEPWELL Decal, "WATCH YOUR STEP", 2.5" Black, Behind Door on Step Riser
47NAB	PAINT COLOR, RUB RAILS 0001 Canyon Black
47NGT	PAINT HOOD TOP 4422 Yellow, Non-Reflecting
47NGW	SEAL, RUB RAILS Top Edge, All Rails
47NHL	LETTERS, E/E WINDOW, RIGHT (2) Decal Sets, "EMERGENCY EXIT", Black, Inside and Outside
47NJA	PAINT COLOR, BODY EXTERIOR 4421 School Bus Yellow
47NJM	PAINT FLASHER BACKGRD 0001 Canyon Black
47NJS	PAINT COLOR, BUMPER Rear, 0001 Canyon Black
47NKD	PAINT COLOR, ROOF 9219 Winter White, Beginning 5" Above Drip
47NKL	PAINT, RUB RAIL Flange to Flange
47NKM	PAINT COLOR, BODY INTERIOR 9384 Spring White
47NKZ	LETTERS, FUEL I.D. Decal; "DIESEL FUEL", 2" Black, Adjacent to Fuel Filler Door
47NMG	OPERATING INSTR, REAR Decal, Inside Rear Emergency Door
47NTE	LOGO, ROOF LINE Decal; Wing and Shield, First Body Section, Above Driver Window and Entrance Door Over Driver Window and Entrance Door
47PAR	BODY CERTIFICATION TAG Mylar Label, with Actual Tire Load Rating
47PCG	HANDLE, ASSIST Windshield Side Mounted, Left and Right, Body Color, with Certain Mirrors Only
47PLX	LETTERS, DEF, I.D. Decal; "DEF ONLY", 1" Black, on DEF Filler Door
47SBS	SUB FLOOR, PLYWOOD Conventional; B-C Exterior Grade, Less Sealed Edges, 5/8", 5 Ply, for 31'2",31'11", 32'8",33'5", 34'2", 34'11", 35'8" Body Lengths
48ACN	SEAT BELT, DRIVER, COLOR with Blaze Orange Seat Belt Webbing
48ANT	WINDOW, DRIVER Laminated, Clear
48APL	WINDOW, STOPS 12" Opening, Only with 78" Headroom
48ARS	WINDOW, SASH (18) 27" Sections, 9"x 23" Opening
48AST	WINDOW, SASH +9 SECTIONS (4) 9" x 32 1/4" Opening
48BAH	WINDOW, E/E, LEFT (2) Vertical Hinge
48BJA	COLOR, WINDOW FRAME, PASS Passenger Window, Natural Aluminum Finish
48BKP	WINDOW, E/E, RIGHT (2) Vertical Hinge
48BUB	WINDOW, PASSENGER, TINT Conventional; 28% Light, Tempered Glass, 78" Headroom, with 34'11", 31'2", 31'11", 32'8", 33'5", 34'2", 35'8" Body Lengths

Vehicle Specifications
2024 INTEGRATED CE S BUS (PB105)

September 09, 2022

<u>Code</u>	<u>Description</u>
48CMY	UPHOLSTERY, DRIVER SEAT, COLOR 2-Tone Gray
48GHC	HEATER, DRIVER 90,000 BTU, with Defroster and without Rear Heat Duct
	<u>Includes</u> : AIR FILTER : HEATER HOSES Premium : HOSE CLAMPS, HEATER HOSE Mubea Constant Tension Clamps
48NAT	FITTINGS, AIR SEAT for Driver Seat
48PAM	WINDSHIELD 3 Flat Pieces, 73% Light, with Band
48PAV	WHEEL POCKET COVER Plastic, ABS
48PAY	AISLE POSITION Center, for balanced seating
48PEW	FLOOR COVERING, COLOR Gray #766
48PJZ	FLOOR COVERING, TYPE {Koroseal} All Body Lengths
48PKC	HOSE CLAMPS, HEATER HOSE Constant Torque for Heater System
48PKM	FLOOR COVERING, TRIM {Koroseal} Plastic Base with PVC Cap
48PKS	FAN, DEFOG RIGHT CENTER 6.50" Diameter, Black, Mounted Over Windshield, 15" Right of Centerline, 2-Speed Switch in Panel
48PMH	HEATER, PASS, LT REAR 50,000 BTU
	<u>Includes</u> : AIR FILTER
48PMM	HEATER, PASS, RT MIDSHIP 1ST 50,000 BTU
	<u>Includes</u> : AIR FILTER
48PNZ	HEATER, WATER PUMP {2 MPU 12} Self Priming, Metal Housing
48PPM	HEATER CUT OFF, VALVE Ball, with Butterfly Handle
48PPS	ROOF VENT, FRONT Static
48PTT	ARM REST, DRIVER, RIGHT {National}
48PUT	NUTS, BELT MOUNTING Standard Nuts For Seat Belt Mounting
48PVB	UPHOLSTERY, DRIVER SEAT, STYLE Plain
48PWD	UPHOLSTERY, PASS SEATS, COLOR Gray, for Seats, Barriers and Head Bumpers
48PWZ	UPHOLSTERY, DRIVER SEAT, TYPE Fabric
48PXA	UPHOLSTERY, BARRIER, TYPE (1-2) Vinyl, 42 oz.
48RAE	BARRIER, CRASH, AFT ENTRY DOOR 39", 1 Leg
48RAL	BARRIER, CRASH, AFT DRIVER 39", 1 Leg
48REP	PANEL, MODESTY, AFT OF DRIVER Mounted Under Barrier
48RET	PANEL, MODESTY, AFT ENTR DOOR Mounted Under Barrier
48RGE	HAND RAIL, ENTRANCE DOOR, FWD Stainless Steel; Curved
48RGR	HAND RAIL, ENTRANCE DOOR, AFT Stainless Steel, 4", Above Step
48RLX	CUSHION, SEAT 15" Depth

Vehicle Specifications
2024 INTEGRATED CE S BUS (PB105)

September 09, 2022

<u>Code</u>	<u>Description</u>
	<u>Includes</u> : WARRANTY Four Years
48RRA	UPHOLSTERY, SEAT, STITCHING Single
	<u>Includes</u> : WARRANTY Two Years
48SAD	SEAT,PASS,LT,26",2 LEG (01)
48SBG	UPHOLSTERY, PASS SEATS, TYPE Vinyl, 42 Ounce
48SDW	SEAT,PASS,LT,39",2 LEG (13)
	<u>Notes</u> : BTI Seating System Base Seat. Retrofittable, Contact IC Bus Application Engineering for more information.
48SKR	SEAT,PASS,RT,39",2 LEG (14)
	<u>Notes</u> : BTI Seating System Base Seat. Retrofittable, Contact IC Bus Application Engineering for more information.
48TZK	SEAT, DRIVER (National Premium) Air Suspension with Suspension Skirt, Triple Chamber Adjustable Air Lumbar, Adjustable Cushion and Back Bolsters, 6 Position Front Cushion Adjuster, 3 Position Rear Cushion Adjuster, 6 to 23 Degree Back Recline
	<u>Includes</u> : SEAT BELT, DRIVER Adjustable D-Loop Seat Belt, Single Locking Retractor
48USV	SEAT BACK, PASSENGER High Back
48UZN	ROOF HATCH, FRONT {Specialty Hybrid Adv H1975-025-191-0F} Emergency Exit with Outside Release, Alarm, English Decals
48UZT	ROOF HATCH, REAR {Specialty Hybrid Adv H1975-025-191-0F} Emergency Exit with Outside Release, Alarm, English Decals
48VVR	STEP TREADS {Koroseal} Pebble White Nosing Only, with Non-Metal Backing, used with Formed Treaded Steps
49002	BODY PLAN, APPROVED VARIATION Number 002
49AHV	LIGHT, STROBE, STOP SIGN, FRT In Lieu Of Flashing Lights Furnished with Stop Sign, Speciality
49AMD	SWITCH, DRIVER PANEL, TYPE Rocker
49AMJ	ALARM, BACKING {Ecco #575} 107 dB
49AMT	CIRCUIT, PROTECTION Breakers, Manual Reset in Lieu of Fuses
	<u>Includes</u> : ACCESS PANEL for Body and Chassis Fuses/Circuit Breakers Located on Body Exterior; Below Driver Window
49AMY	SWITCH, REAR DOOR BUZZER for Emergency Door
49ANH	SWITCH, MAGNETIC, DISCONNECT Master, Ignition Operated, All Body Circuits
49ANU	SOURCE, POWER 12 VDC, Mounted In Dash
49AUM	SWITCH, MASTER FLASHER Omit Master Flasher Switch, 8-Lamp System
49AWV	SPEAKERS AND WIRING (8) Flush Mounted In Light Bar
49BCL	FLASHER SYSTEM (8) Warning Lights, 8-Lamp System, Electronic Relay Flasher, Sequential Operation, Red Lights Activate after Amber Lights, with Road Speed Parameters

Vehicle Specifications
2024 INTEGRATED CE S BUS (PB105)

September 09, 2022

<u>Code</u>	<u>Description</u>
49BCR	LIGHT, EXTERIOR, CHECK Automatically Activates Lights for Pre Trip Inspection
49BEW	MIRROR, REAR VIEW, EXTERIOR {Mirror Lite Super Nickels} Black, Motorized Head, Heated
49BMA	STOP ARM, FRONT {Specialty 2980} Air, 18" Octagon, Double Sided, 1/2" White Border, Hi Intensity Grade, Strobing LED Lights
49BUT	VISOR, INTERIOR, LEFT FRONT 6" x 30", Transparent, For Left Windshield, with Finger Hold Adjustment Knob
49BVD	SWITCH, BATTERY Shut-Off, 300A Weather Resistant, In Battery Compartment
49BVE	MIRROR, CROSS VIEW, EXTERIOR (2) {Mirror Lite High Definition Busboy} Black
49BYT	LIGHTS, STOP (2) {Sound Off/OptiLuxx} and Tail; 7" Round LED, Red
49BYZ	LIGHTS, DIRECTIONAL, REAR (2) {Sound Off/OptiLuxx} LED, 7" Round Amber
49BZG	LIGHTS, BACK UP (2) {Sound Off/OptiLuxx} LED, 7" Round Clear
49CKT	FUEL FILLER PIPE Low Profile Neck Cap and Vent Hosing, for Use with Right Side Fill for Between the Rail Fuel Tanks, for Above the Floor Fuel Fill, for 25 GPM Fill Rate Only
49CLM	RADIO, ENTERTAINMENT AM/FM/USB Input/Auxiliary Input, Includes Antenna and Cable, with Public Address System
49DAG	LIGHT, INDIC, WARNING LIGHTS LED Type; Red and Amber
49DBR	HOOD, WARNING LAMP (4) Black, 8-Lamp System, One Hood Above Two Lights
49DDC	LIGHTS, CLUSTER {Truck Lite 07045A & 07045R} LED; Amber Front and Red Rear
49EAX	LIGHTS, DIRECTIONAL, SIDE (4) {Sound Off/OptiLuxx} Rectangular LED Armored, 2 Each Side First Section Aft Entrance Door & Forward Rear Wheel Pocket
49ENR	VISOR, INTERIOR, DRIVER LEFT 10" X 30" for Driver's Window
49ESC	LIGHTS, DOME, DRIVER {Sound Off/OptiLuxx} (1) LED, Rectangular, Mounted In Light Bar in Ceiling, with Separate Switch
49EUB	KIT, FIRST AID Metal; 24 Unit, Spec State
49EVL	SWITCH, NOISE SUPPRESSION Actuator Legend States, "NOISE SUPP ", for Separate Solenoid, with Red Switch in Panel
49GBG	KIT, BODY FLUID Arizona, Mounted on the Bulkhead
49GBV	WINDSHIELD WIPERS (2) Cowl Mounted <u>Includes</u> : WINDSHIELD WIPERS CONTROL Single Motor, Overlapping Wipe Pattern
49GDG	PADDING COMPART ABOVE DRIVER Window; Safety Equipment Compartment, with Cutout for Dome Light
49GDS	COMPARTMENT ABOVE DRIVER Left of the Driver <u>Includes</u> : COMPARTMENT ABOVE DRIVER Compartment Size: 39" x 10" x 10" : HINGES Piano Type
49GGE	FIRE EXTINGUISHER, DRIVER AREA 5 lb 2A-40BC Minimum, with Flexible Hose and Metal Nozzle
49GHN	REFLECTORS, REAR (2) 3", Red, Adhesive Back
49GHR	REFLECTORS, SIDE, REAR (2) 3", Red, Adhesive Back
49GHV	REFLECTORS, SIDE, FRONT (2) 3", Amber; Adhesive Back, 1 Aft Drivers Window Left, 1 Aft Entrance Door Right

Vehicle Specifications
2024 INTEGRATED CE S BUS (PB105)

September 09, 2022

<u>Code</u>	<u>Description</u>
49GHX	REFLECTORS, SIDE, INTERMEDIATE (2) 3" Amber, 1 Each Side, Below The Third Rub Rail From the Top, Adhesive Back
49GKL	SAFETY TRIANGLES 1 Kit; Warning Reflectors, Mounted on Floor Between Driver Seat and Drivers Crash Barrier/Stanchion
49GKZ	FUEL FILLER DOOR with Non-Locking Latch
49GUK	FENDERS, RUBBER, REAR (2)
49GUM	INSPECTION PLATE Fuel Sending Unit 8" x 8" Steel
49GUX	MUD FLAPS, FRONT WHEELS (2) Rubber
49GVH	MUD FLAPS, REAR WHEELS (2) Brackets Only
49GWW	WINDSHIELD WASHER Kit; 6 Quart Capacity, Bottle
	<u>Includes</u>
	: WINDSHIELD WASHER ELECTRICAL CONNECTIONS Sealed and Locking Type
49JAD	DEF FILLER DOOR with Locking Latch
49JBP	LIGHTS, DOME {Sound Off/OptiLuxx} (07) LED, Rectangular Recessed Type, Mounted in Light Bar
49JBU	LIGHT, ENTRY DOOR {Sound Off/OptiLuxx} LED; 4" Oval; Light Mounted in Skirt Behind Entrance Door, Wired To Step Light
49JBX	LIGHT, STEP {Sound Off/OptiLuxx} 4" Round LED, White, Wired to Ignition, Operated by Entrance Door
49JBY	LIGHTS, MARKER, FRONT & REAR (4) {Sound Off/OptiLuxx} LED, Armored, Slim-Line, (2) Amber Front and (2) Red Rear
49MRN	MIRROR, INSIDE 6" x 30" with Lever Lock
49MZV	LATCH, COMPARTMENT Locking, for Overhead Storage Compartment
49NGB	LIGHT, COMPARTMENT, ENGINE {Sound Off/OptiLuxx} LED 4" Oval; Activated with Parking Lights, with On/Off Switch, Includes Limit Switch that Allows Light to come on When Hood is Opened
49NGG	LIGHTS, TAIL, LICENSE PLATE (2) {Sound Off/OptiLuxx} 4" Round LED, Red, Includes Stop & Light Window, Includes Mounting Gasket
49NGJ	LIGHTS, WARNING (8) {Sound Off/OptiLuxx} (4) 7" Round Red Strobing LED and (4) 7" Round Amber Strobing LED, 2 Front, 2 Rear Each Color
49UAC	STATE OF OPERATION Arizona
49ZNE	LIGHTS, MARKER, SIDE, INTERMED {Sound Off/OptiLuxx} LED, Amber, Slim-Line, Armored, Intermediate, Centered, Required for Units 30 Foot or Longer
50XZZ	BODY PLAN, NON-SPECIAL NEEDS Conventional; 35' 8" Body Length, +9 Section Front & Rear, 83 Passenger, 276" WB, DJ1055A000
7382135415	(2) TIRE, FRONT 11R22.5 Load Range H HSR2 (CONTINENTAL), 498 rev/mile, 75 MPH, All-Position
7382135415	(4) TIRE, REAR 11R22.5 Load Range H HSR2 (CONTINENTAL), 498 rev/mile, 75 MPH, All-Position

Services Section:

40126	WARRANTY Standard for CE, RE, BE School Bus Models, Effective with Vehicles Built March 1, 2017 or Later, CTS-3304H
40PLB	SRV CONTRACT, EXT VEH COVERAGE {Navistar} To 36-Month/50,000 Miles (80,000 km), Covers 100% Parts and Labor; Includes Body; Excludes Extending Warranty for Engine, Transmission, Perforation or Corrosion of Cab/Cowl Structure and Paint

Vehicle Specifications
2024 INTEGRATED CE S BUS (PB105)

September 09, 2022

<u>Code</u>	<u>Description</u>
40RAT	SERVICES, TOWING {Navistar} Service Call to 60-Month/Unlimited Mileage to the Nearest IC Bus Dealer for Navistar Warrantable Failure as Contract Defined; Includes Engine Failure if Supplier Declines Tow Coverage & ESC Supplied thru Navistar; \$1100 (USA) Maximum Benefit per Incident

49GVN	WARRANTY 5-Year, Limited
-------	--------------------------

Body/Allied Equipment

<u>Code</u>	<u>Description</u>
-------------	--------------------

Goods Purchased

<u>Code</u>	<u>Description</u>
-------------	--------------------

Turning Radius Summary
2024 INTEGRATED CE S BUS (PB105)

September 09, 2022

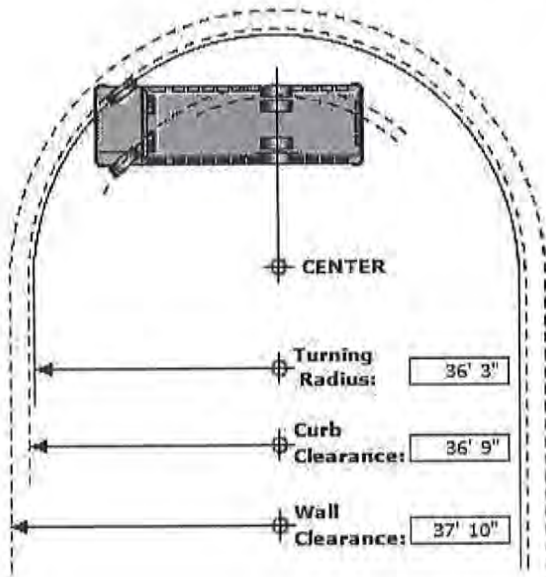

Series: INGB
 Model: PB105
 Description: INTEGRATED CE S BUS
 Model Year: 2024

Calculation Factors

Wheelbase: 276
 Front Axle: 0002ASH
 Description: AXLE, FRONT NON-DRIVING, {Meritor MFS-10-122A} I-Beam Type, 10,000-lb Capacity
 Front Wheel: 0027DUW
 Description: WHEELS, FRONT, {Accuride 51408} DISC; 22.5x8.25 Rims, Powder Coat Steel, 2-Hand Hole, 10-Stud, 285.75mm BC, Hub-Piloted, Flanged Nut, with Steel Hubs
 Front Tire: 07382135415
 Description: TIRES, 11R22.5 Load Range H HSR2 (CONTINENTAL), 498 rev/mile, 75 MPH, All-Position
 Steering Gear: 0005PRR
 Description: STEERING GEAR, {TRW (Ross) TAS66} Power

Turning Radius Statistics

General Information

Inside Turn Angle: 50 Degrees
 Radial Overhang: 19

Axle Information

KingPin Inclusion: 6.25 Degrees
 KingPin Center: 69

Turning Radius - Curb View

C	- Curb Contact Length:	15.91
CI	- Curb Clearance Increment:	5.84
CR	- Curb Clearance Radius:	36'9"
CH	- Curb Height:	6"
TR	- Turning Radius:	36'3"
TW	- Tire Width:	11.10

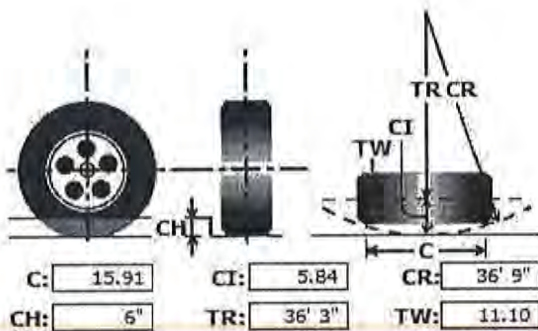

* All Measurements are in inches, unless otherwise specified.

This information is based on engineering information available at this time. Actual figures may vary. Navistar, Inc. cannot accept liability for consequences due to this variance.

Date: 3/10/23
Quote Valid Until:
Prepared By: TOM HARTMAN



Name:
Organization: EQUALIS GROUP
Address:
City, State ZIP:
Phone:

YEAR:	2024
MAKE:	IC
MODEL:	CE CUMMINS DIESEL
CAPACITY:	77
STOCK #'S:	RWCICCED-2

		\$ 220,000.00
INCLUDES 3 CAMERA SYSTEM AND DVR INCLUDES AC SYSTEM EV FREEBLOW		
TRADE BUS #:		Trade Total: \$ -
		Pre Tax Sub Total: \$ 220,000.00
		Sales Tax (): \$ -
Local Delivery Charge: 0		\$ -
		\$ -
TOTAL PRICE:		\$ 220,000.00

RWC RECEIVED - 77 pass Diesel Cummins

September 09, 2022

Prepared For:
RWC International Ltd
TOM HARTMAN
2202 S Central Ave.
Phoenix, AZ 85004-2908
(602)307 - 1050
Reference ID: CE3411-276-77*

Presented By:
RWC Group
Julie Shockley
600 North 75th Avenue
PHOENIX AZ 85043 -
(602)307-1050

Model Profile
2024 INTEGRATED CE S BUS (PB105)

APPLICATION: School Transportation
MISSION: Requested GVWR: 31000. Calc. GVWR: 31000
Calc. Start / Grade Ability: 23.21% / 1.92% @ 55 MPH
Calc. Geared Speed: 92.5 MPH

DIMENSION: Wheelbase: 276.00, CA: N/A, Axle to Frame: 166.00
ENGINE, DIESEL: {Cummins B6.7 260} EPA 2021, 260HP @ 2400 RPM, 660 lb-ft Torque @ 1600 RPM, 2600 RPM
Governed Speed, 260 Peak HP (Max), School Bus Only

TRANSMISSION, AUTOMATIC: {Allison 2500 PTS} 6th Generation Controls, Wide Ratio, 6-Speed with Double Overdrive, Less
PTO Provision, Less Retarder, with 33,000-lb GVW and GCW Max, School Bus

CLUTCH: Omit Item (Clutch & Control)

AXLE, FRONT NON-DRIVING: {Meritor MFS-10-122A} I-Beam Type, 10,000-lb Capacity

AXLE, REAR, SINGLE: {Dana Spicer S140} Single Reduction, 21,000-lb Capacity, 190 Wheel Ends Gear Ratio: 5.29

TIRE, FRONT: (2) 11R22.5 Load Range H HSR2 (CONTINENTAL), 498 rev/mile, 75 MPH, All-Position

TIRE, REAR: (4) 11R22.5 Load Range H HSR2 (CONTINENTAL), 498 rev/mile, 75 MPH, All-Position

SUSPENSION, REAR, AIR, SINGLE: {International IROS} 21,000-lb Capacity, 9.25" Ride Height, with Shock Absorbers

PAINT: Cab schematic 101NB
Location 1: 4421, School Bus Yellow (Std)
Location 2: 4422, School Bus Yellow Non Reflective (Nrf)
Chassis schematic N/A

Vehicle Specifications
2024 INTEGRATED CE S BUS (PB105)

September 09, 2022

Code	Description
PB10500	Base Chassis, Model INTEGRATED CE S BUS with 276.00 Wheelbase, N/A CA, and 166.00 Axle to Frame.
1570	TOW HOOK, FRONT (2) Frame Mounted
1CAC	FRAME RAILS High Strength Low Alloy Steel (50,000 PSI Yield); 10.125" x 3.062" x 0.312" (257.2mm x 77.8mm x 8.0mm); 489.2" (12425mm) Maximum OAL <u>Includes</u> : CHASSIS PAINT Chassis Painted Prior to Body Mounting : FRAME RAILS All holes Laser Aligned and Machine Punched, Powder Coated Prior to Full Assembly, Assembled in Fixture using "Grade 8" Bolts : FRAME REINFORCEMENT, SPECIAL 3.30" x 1.80" x 0.312" x 31.50" Inverted "L" in Front Shock Absorber Mounting Area
1LLE	BUMPER, FRONT Contoured, Steel, Severe Duty <u>Includes</u> : BUMPER, FRONT THICKNESS 1/4 Inch
1LNT	CROSSING GATE, FRONT Omit Item <u>Includes</u> : CROSSING GATE, FRONT Matches Contour of Bumper
1SAM	CROSSMEMBER, REAR, AF (2)
1WJE	WHEELBASE RANGE 276" (700cm) Only
2ASH	AXLE, FRONT NON-DRIVING {Meritor MFS-10-122A} I-Beam Type, 10,000-lb Capacity <u>Includes</u> : AXLE, FRONT SQUARING to Plus or Minus .015 Inch, using a Special Fixture to Assure Parallelism of Springs <u>Notes</u> : The following features should be considered when calculating Front GAWR: Front Axles; Front Suspension; Brake System; Brakes, Front Air Cam; Wheels; Tires.
3ADB	SUSPENSION, FRONT, SPRING Parabolic Taper Leaf, Shackle Type, 10,000-lb Capacity, with Shock Absorbers <u>Includes</u> : SPRING PINS Bolt and Nut Type : SPRING PINS Rubber Bushings, Maintenance-Free <u>Notes</u> : The following features should be considered when calculating Front GAWR: Front Axles; Front Suspension; Brake System; Brakes, Front Air Cam; Wheels; Tires.
4091	BRAKE SYSTEM, AIR Dual System for Straight Truck Applications <u>Includes</u> : BRAKE LINES Color and Size Coded Nylon : DRAIN VALVE Twist-Type : GAUGE, AIR PRESSURE (2) Air 1 and Air 2 Gauges; Located in Instrument Cluster : PARKING BRAKE CONTROL Yellow Knob, Located on Instrument Panel : PARKING BRAKE VALVE For Truck : QUICK RELEASE VALVE On Rear Axle for Spring Brake Release: 1 for 4x2, 2 for 6x4 : SPRING BRAKE MODULATOR VALVE R-7 for 4x2, SR-7 with relay valve for 6x4/8x6 <u>Notes</u> : Rear Axle is Limited to 19,000-LB GAWR with Code 04091 BRAKE SYSTEM, AIR and Code 04NDC BRAKES, REAR, AIR CAM Regardless of Axle/Suspension Ordered : Rear Axle is Limited to 20,000-LB GAWR with Code 04092 BRAKE SYSTEM, AIR and Code 04NCW BRAKES, REAR, AIR CAM Regardless of Axle/Suspension Ordered

Vehicle Specifications
2024 INTEGRATED CE S BUS (PB105)

September 09, 2022

<u>Code</u>	<u>Description</u>
4AZS	AIR BRAKE ABS {Bendix AntiLock Brake System} 4-Channel (4 Sensor/4 Modulator) Electronic Stability Program, with Automatic Traction Control
4EBS	AIR DRYER {Bendix AD-9} with Heater
4EXP	BRAKE CHAMBERS, FRONT AXLE {Bendix} 20 Sqn
4EXU	BRAKE CHAMBERS, REAR AXLE {Bendix EverSure} 30/30 Sqn Spring Brake
4GBM	BRAKE, PARKING Manual Push-Pull Pneumatic Parking Brake
4LAG	SLACK ADJUSTERS, FRONT {Gunitite} Automatic
4LGG	SLACK ADJUSTERS, REAR {Gunitite} Automatic
4SPA	AIR COMPRESSOR {Cummins} 18.7 CFM
4VCY	AIR TANK LOCATION (1) Mounted Left Side to Provide Clearance for Larger Body Builder Supplied Battery Box
4WWX	DRAIN VALVE {Humphrey} (3) Air Operated, with Controls in Drivers Compartment, for Air Tanks
4WZT	GVWR LIMITATION FOR BUS with Air Brakes, Limited to 33,000-lbs Maximum to meet FMVSS 121 Requirements, for Conventional Bus
4XDP	BRAKES, FRONT {Meritor 16.5X5 Q-PLUS CAST} Air S-Cam Type, Cast Spider, Fabricated Shoe, Double Anchor Pin, Size 16.5" X 5", 14,700-lb Capacity
4XDR	BRAKES, REAR {Meritor 16.5X7 Q-PLUS CAST} Air S-Cam Type, Cast Spider, Fabricated Shoe, Double Anchor Pin, Size 16.5" X 7", 23,000-lb Capacity per Axle
5710	STEERING COLUMN Tilting and Telescoping
5CAL	STEERING WHEEL 2-Spoke, 18" Dia., Black
5PRR	STEERING GEAR {TRW (Ross) TAS66} Power
6DGA	DRIVELINE SYSTEM {Dana Spicer} SPL100, for 4x2/6x2
7BMK	EXHAUST SYSTEM Horizontal Aftertreatment System, Frame Mounted Under Right Rail, for Single Long Horizontal Tail Pipe
7WBL	TAIL PIPE (1) Horizontal, Long, Exits Left Side Through Bumper
8000	ELECTRICAL SYSTEM 12-Volt, Standard Equipment
	<u>Includes</u>
	: HAZARD SWITCH Push On/Push Off, Located on Top of Steering Column Cover
	: HEADLIGHT DIMMER SWITCH Integral with Turn Signal Lever
	: MISCELLANEOUS FEATURES Modular, Loom Protected, Grommets in all Applicable Body Openings, Assembled in Computer Assisted Fixture which Verifies Continuity and Correct Assembly Prior to Installation
	: PARKING LIGHT Integral with Front Turn Signal and Rear Tail Light
	: STARTER SWITCH Electric, Key Operated
	: TURN SIGNAL FLASHER
	: TURN SIGNAL SWITCH Self-Cancelling with Lane Change Feature
	: TURN SIGNALS, FRONT Includes Reflectors; Flush Mounted
	: WINDSHIELD WIPER SWITCH 2-Speed with Wash and Intermittent Feature (5 Pre-Set Delays), Integral with Turn Signal Lever
	: WIRING, CHASSIS Color Coded and Continuously Numbered
8GXK	ALTERNATOR {Leece-Neville BLP4006HN} Brushless, 12 Volt, 325 Amp Capacity, Pad Mount, with Remote Sense
8MSG	BATTERY SYSTEM {Fleetrite} Maintenance-Free, (3) 12-Volt 1980CCA Total, Top Threaded Stud

Vehicle Specifications
2024 INTEGRATED CE S BUS (PB105)

September 09, 2022

<u>Code</u>	<u>Description</u>
8TTK	BATTERY BOX Steel, with Sliding Tray, 25.25" Wide, for Standard Batteries, 1-3 Battery Capacity, Mounted Left Side Behind Front Axle Perpendicular to Frame Rail
8TUT	COLLISION MITIGATION SYSTEM Omit
8VBC	HORN, ELECTRIC (2) Trumpet Style, Mounted Above Left Frame Rail
8WPB	HEADLIGHTS Halogen, Composite Aero Design, with Daytime Running Lights
8WTK	STARTING MOTOR {Delco Remy 38MT Type 300} 12 Volt, Less Thermal Over-Crank Protection
8WWJ	INDICATOR, LOW COOLANT LEVEL with Audible Alarm
8WXB	HEADLIGHT WARNING BUZZER Sounds When Head Light Switch is on and Ignition Switch is in "Off" Position
8XAH	CIRCUIT BREAKERS Manual-Reset (Main Panel) SAE Type III with Trip Indicators, Replaces All Fuses
9AAE	LOGOS EXTERIOR, ENGINE Badges
9WAB	HOOD TILT ASSIST {EASY TILT} Mechanical
9WAY	FRONT END Tilting, Fiberglass, with Three Piece Construction
	<u>Includes</u> : AIR INTAKE SYSTEM Integrated Pre-Cleaning System to Enhance Air Filter Life : GRILLE Removable; Fiberglass Painted Hood Color : SPLASH SHIELD Integral with Front End Assembly
10020	CHASSIS PAINT Full Chassis
10063	PAINT SCHEMATIC, PT-1 Two Tone, Design 101 for Non-Reflecting Schoolbus Hood
10661	PAINT, NON-REFLECTING Non-Reflecting Paint
10788	PAINT TYPE Urethane, One or Two Colors, Other than Imron or International.
10XAK	PROMOTIONAL PACKAGE 7 Year Unlimited Miles/km Warranty, Limited Time Program for Allison 2500 Series Transmission on School and Commercial Buses (Supplied directly through Allison)
11001	CLUTCH Omit Item (Clutch & Control)
12703	ANTI-FREEZE Red, Extended Life Coolant; To -40 Degrees F/ -40 Degrees C, Freeze Protection
12ERU	ENGINE, DIESEL {Cummins B6.7 260} EPA 2021, 260HP @ 2400 RPM, 660 lb-ft Torque @ 1600 RPM, 2600 RPM Governed Speed, 260 Peak HP (Max), School Bus Only
12TSY	FAN DRIVE {Borg-Warner SA85} Viscous Type, Screw On
	<u>Includes</u> : FAN Nylon
12UGN	THROTTLE, HAND CONTROL Electronic
	<u>Notes</u> : Cruise Control Switches Mounted on Steering Wheel are Non-Illuminated.
12UYE	RADIATOR Aluminum, 2-Row, Cross Flow, Over Under System, 717 SqIn Louvered, with 313 SqIn Charge Air Cooler, Includes In-Tank Oil Cooler
	<u>Includes</u> : DEAERATION SYSTEM with Surge Tank : HOSE CLAMPS, RADIATOR HOSES Gates Shrink Band Type; Thermoplastic Coolant Hose Clamps : RADIATOR HOSES Premium, Rubber
12VBR	AIR CLEANER with Service Protection Element
	<u>Includes</u>

Vehicle Specifications
2024 INTEGRATED CE S BUS (PB105)

September 09, 2022

<u>Code</u>	<u>Description</u>
	: GAUGE, AIR CLEANER RESTRICTION Air Cleaner Mounted
12VJB	EMISSION, CALENDAR YEAR {Cummins B6.7} EPA, OBD and GHG Certified for Calendar Year 2022
12VVN	CRUISE CONTROL Electronic
	<u>Notes</u>
	: Cruise Control Switches Mounted on Steering Wheel are Non-Illuminated.
12VWH	GOVERNOR Electronic Road Speed Type; for Electronic Engines and Bus Models; with 55 MPH Default
12VYV	IDLE MANAGEMENT SYSTEM Ramp Engine Speed with Air Condition On, in Neutral and Parking Brake Set, Accommodation Package
12WAE	HOSE CLAMPS, RADIATOR HOSES Constant Torque, for Engine Hoses 1.0" I.D. and Over
12WSY	BLOCK HEATER, ENGINE {Phillips} 120V/750W, for Cummins ISB/B6.7 Engines
12WZE	CARB IDLE COMPLIANCE Federal, Does Not Comply with California Clean Air Idle Regulations
12XCS	CARB EMISSION WARR COMPLIANCE Federal, Does Not Comply with CARB Emission Warranty
13BBP	TRANSMISSION, AUTOMATIC {Allison 2500 PTS} 6th Generation Controls, Wide Ratio, 6-Speed with Double Overdrive, Less PTO Provision, Less Retarder, with 33,000-lb GVW and GCW Max, School Bus
13WLN	TRANSMISSION OIL Synthetic; 20 thru 28 Pints
13WVW	NEUTRAL AT STOP OMIT
13WYY	SHIFT CONTROL PARAMETERS {Allison} 1000 or 2000 Series Transmissions, Performance Programming
14AKC	AXLE, REAR, SINGLE {Dana Spicer S140} Single Reduction, 21,000-lb Capacity, 190 Wheel Ends . Gear Ratio: 5.29
14TBS	SUSPENSION, REAR, AIR, SINGLE {International IROS} 21,000-lb Capacity, 9.25" Ride Height, with Shock Absorbers
	<u>Notes</u>
	: The following features should be considered when calculating Rear GAWR: Rear Axles; Rear Suspension; Brake System; Brakes, Rear Air Cam; Brake Shoes, Rear; Special Rating, GAWR; Wheels; Tires.
15SJT	FUEL TANK Top Draw, Steel, Rectangular, 100 US Gal (379L), Includes Protective Cage, with Low Profile Fuel Filler Assembly and Vent Hosing, Mounted Between Frame Rails and Behind Rear Axle
15WEP	DEF TANK 16.5 US Gal (62.5L) Capacity, Frame Mounted Outside Right Rail, Behind 0 Bow
16010	COWL Flat Back
16HBA	GAUGE CLUSTER English with English Electronic Speedometer
	<u>Includes</u>
	: GAUGE CLUSTER (5) Engine Oil Pressure (Electronic), Water Temperature (Electronic), Fuel (Electronic), Tachometer (Electronic), Voltmeter
	: ODOMETER DISPLAY, Miles, Trip Miles, Engine Hours, Trip Hours, Fault Code Readout
	: WARNING SYSTEM Low Fuel, Low Oil Pressure, High Engine Coolant Temp, and Low Battery Voltage (Visual and Audible)
16HGH	GAUGE, OIL TEMP, AUTO TRANS for Allison Transmission
16HHE	GAUGE, AIR CLEANER RESTRICTION {Filter-Minder} with Black Bezel, Mounted in Instrument Panel
16HKT	IP CLUSTER DISPLAY On Board Diagnostics Display of Fault Codes in Gauge Cluster
16HLJ	GAUGE, DEF FLUID LEVEL
16VCD	DASH INSULATOR

Vehicle Specifications
2024 INTEGRATED CE S BUS (PB105)

September 09, 2022

Code	Description
27DUW	WHEELS, FRONT {Accuride 51408} DISC; 22.5x8.25 Rims, Powder Coat Steel, 2-Hand Hole, 10-Stud, 285.75mm BC, Hub-Piloted, Flanged Nut, with Steel Hubs
28DUW	WHEELS, REAR {Accuride 51408} DUAL DISC; 22.5x8.25 Rims, Powder Coat Steel, 2-Hand Hole, 10-Stud, 285.75mm BC, Hub-Piloted, Flanged Nut, with Steel Hubs
47AJC	BODY TAG, METAL Capacity to Include the Total Number of Passengers
47AMG	BODY, BUS Conventional; 78" Headroom, 34'11" Body Length, +9 Section Rear, 78 Passenger, 276 WB <u>Includes</u> : NOTE: Body Mandates Overall Vehicle Length of Greater than 40 Feet
47APR	HEADLINER, BODY Conventional; 25'11"-35'08" Body Length, Perforated Full Length with Sound Insulation Full Length
47APW	FASTENERS, HEADLINER Rivets
47ARH	BOWS, ROOF 14 ga., One Piece Construction <u>Includes</u> : BOWS, ROOF Positioned Floor Line to Floor Line, Threaded Through Roof Strainers and Drip Rail
47ARP	LIGHT BARS Plastic
47ATB	SKIRT, BODY Conventional, 20", 16ga., 31'2", 31'11", 32'8", 33'5", 34'2", 34'11", 35'8" Body Lengths <u>Includes</u> : SKIRT, BODY Extra Smooth Steel Supported by Floor Gussets
47AUR	TIE DOWNS, BODY Grade 8 Bolts, Every Body Section <u>Includes</u> : TIE DOWNS, BODY with Formed Tab that Fits into Floor Structure to Prevent Turning
47AXT	RUB RAILS, BODY (4) Conventional; Steel, 31'2", 31'11", 32'8", 33'5", 34'2", 34'11", 35'8" Body Lengths, Includes Snow Rail <u>Includes</u> : RUB RAILS Full Length, Primer Coated (Both Sides), Attached to Body without Cuts or Splices
47AYB	BODY, REAR Includes Emergency Door <u>Includes</u> : DOOR, REAR EMERGENCY with Concealed Hinges : HEADER BUMPER Padded, Mounted Over Rear Door; Upholstered to Match Passenger Seat Color
47AZE	SIDE SHEET, BODY, EXTERIOR Conventional, 16ga., Smooth, 31'2", 31'11", 32'8", 33'5", 34'2", 34'11", 35'8" Body Lengths
47AZL	FLOOR, BODY with Wheel Wells
47AZX	RAILS, WRAP-AROUND, FLOOR At Floor Level To Rear Door Post
47AZZ	RAILS, WRAP-AROUND Just Below Window Line
47BAK	BUMPER, REAR Painted, 12" High, 3/16" Thick
47BAR	SUPPORTS, REAR BUMPER Bolted to Frame
47BAW	TOW HOOK, LEFT REAR (01)
47BAX	TOW HOOK, RIGHT REAR (01)
47BBH	LINING, SIDE INTERIOR, LOWER Embossed Steel, Clear Coated
47BBZ	SEALER Extra; Sidewall to Floor, In Wheel Pocket Area, and Rear Wall to Floor

Vehicle Specifications
2024 INTEGRATED CE S BUS (PB105)

September 09, 2022

<u>Code</u>	<u>Description</u>
47BLD	STEP, FRONT ENTRANCE DOOR 27 1/4" Depth; 14ga Steel, Formed Treads, Naviflex Finish
47DAJ	COVER, REAR DOOR INSIDE HANDLE Partial Coverage
47DAK	FASTENERS, REAR DOOR Bolts and Nutserts, Rear Door To Body
47DBP	DOOR, ENTRANCE, FRONT Air, Outward Opening, with Split Pane Glass
47DDE	HANDLE, ASSIST, ENTRANCE DOOR Outside Entrance
47DDH	HOLD BACK, REAR DOOR Stationary, No Cables, with Plastic Cover
47DDU	LATCH, REAR DOOR One Point Slide Bar, Cam Operated, with One Inch Stroke
47DEK	LOCK, REAR DOOR with Ignition Starter Interlock
47DEY	HANDLE, EXTERIOR, REAR Emergency Door; Yellow
47DNK	SWITCH, LOCATION Steering Wheel; Includes Master Flasher, Flasher On/Off, Red Override, and Door Control
	<u>Includes</u> : SWITCH, STEERING WHEEL, LIGHT Includes Illuminated Switches
47DWV	KEYS ALIKE, LOCKS Entrance Door, 545 Keys
47EBM	HOLD DOWN, BATTERY For (2) Standard Size Batteries
47ETG	COMPARTMENT, LUGGAGE, RT MID 66" X 24" X 22"
	<u>Includes</u> : HINGES Rubber : LATCH, T-HANDLE, LOCKING Stainless Steel
47EXK	LOCK, ENTRANCE DOOR Integrated Manual Control in Door, with Key
47KDC	MONITOR, POST TRIP INSPECTION (Leave No Student Behind) Accessory Controlled, with Push Button Alarm Disable at Rear of Bus in Light Bar Prompts Driver to Walk to Back of Bus to Disable Alarm
47LAB	NOISE REDUCTION, DRIVER FLOOR Insulation Covering Complete Driver Floor Area
47LAT	NOISE REDUCTION, ROOF BOW Conventional; Insulation, 31'2", 31'11", 32'8", 33'5", 34'2", 34'11", 35'8" Body Lengths
47LAU	INSULATION, ROOF/SIDES/BULKHEAD 1.5"
47MBA	UNDERCOAT, BODY Fire Resistant, Water Based, TT-C-730 Spec
	<u>Includes</u> : UNDERCOATING Performed Before and After Mounting on Chassis
47MJR	LETTERS, DOOR, REAR Decals; "EMERGENCY DOOR", 2" Black Letters Inside and Outside
47MNM	LETTERS, BATTERY COMPARTMENT (01) Decal; "Battery"; 2" Black Letters, Centered on Standard Battery Box
47MNV	ARROW, RR DOOR, OUTSIDE Decal; Black .75" Stroke, Indicating Handle Direction
47MPD	LETTERS, SCHOOL BUS FRONT/REAR Decal; "SCHOOL BUS"; with 8" Black Reflective Letters On Front and Rear Cap
47MRN	STRIPING, E/E WINDOW, LEFT (02) Perimeter, 1" Yellow
47MRU	LETTERS, E/E WINDOW, LEFT (2) Decal Sets, "EMERGENCY EXIT", Black Inside and Outside
47MSA	STRIPING, PERIMETER, REAR Emergency Door, 1" Yellow Reflective
47MSE	STRIPING, REAR END 2" Yellow

Vehicle Specifications
2024 INTEGRATED CE S BUS (PB105)

September 09, 2022

<u>Code</u>	<u>Description</u>
47MSJ	STRIPING, ROOF HATCH, FRONT Decal, Perimeter, 1" Yellow
47MSK	STRIPING, ROOF HATCH, REAR Decal, Perimeter, 1" Yellow
47MSS	STRIPING, SEATLINE 2" Yellow
47MTY	WIRING DIAGRAM Schematic, Electrical
	<u>Includes</u> : ACCESS PANEL for Wiring Diagram Schematic Located on Body Exterior; Below Driver Window
47MUP	STRIPING, E/E WINDOW, RIGHT (02) Perimeter, 1" Yellow
47MVA	LETTERS, HEADER Decal; "WATCH YOUR STEP", 1" Black, Above Windshield
47MVC	LETTERS, STEPWELL Decal, "WATCH YOUR STEP", 2.5" Black, Behind Door on Step Riser
47NAB	PAINT COLOR, RUB RAILS 0001 Canyon Black
47NGT	PAINT HOOD TOP 4422 Yellow, Non-Reflecting
47NGW	SEAL, RUB RAILS Top Edge, All Rails
47NHL	LETTERS, E/E WINDOW, RIGHT (2) Decal Sets, "EMERGENCY EXIT", Black, Inside and Outside
47NJA	PAINT COLOR, BODY EXTERIOR 4421 School Bus Yellow
47NJM	PAINT FLASHER BACKGRD 0001 Canyon Black
47NJS	PAINT COLOR, BUMPER Rear, 0001 Canyon Black
47NKD	PAINT COLOR, ROOF 9219 Winter White, Beginning 5" Above Drip
47NKL	PAINT, RUB RAIL Flange to Flange
47NKM	PAINT COLOR, BODY INTERIOR 9384 Spring White
47NKZ	LETTERS, FUEL I.D. Decal; "DIESEL FUEL", 2" Black, Adjacent to Fuel Filler Door
47NMG	OPERATING INSTR, REAR Decal, Inside Rear Emergency Door
47NTE	LOGO, ROOF LINE Decal; Wing and Shield, First Body Section, Above Driver Window and Entrance Door Over Driver Window and Entrance Door
47PAR	BODY CERTIFICATION TAG Mylar Label, with Actual Tire Load Rating
47PCG	HANDLE, ASSIST Windshield Side Mounted, Left and Right, Body Color, with Certain Mirrors Only
47PLX	LETTERS, DEF, I.D. Decal; "DEF ONLY", 1" Black, on DEF Filler Door
47SBS	SUB FLOOR, PLYWOOD Conventional; B-C Exterior Grade, Less Sealed Edges, 5/8", 5 Ply, for 31'2",31'11", 32'8",33'5", 34'2", 34'11", 35'8" Body Lengths
48ACN	SEAT BELT, DRIVER, COLOR with Blaze Orange Seat Belt Webbing
48ANT	WINDOW, DRIVER Laminated, Clear
48APL	WINDOW, STOPS 12" Opening, Only with 78" Headroom
48ARU	WINDOW, SASH (20) 27" Sections, 9"x 23" Opening
48ASP	WINDOW, SASH +9 SECTIONS (2) 9" x 32 1/4" Opening
48BAH	WINDOW, E/E, LEFT (2) Vertical Hinge
48BJA	COLOR, WINDOW FRAME, PASS Passenger Window, Natural Aluminum Finish
48BKP	WINDOW, E/E, RIGHT (2) Vertical Hinge

Vehicle Specifications
2024 INTEGRATED CE S BUS (PB105)

September 09, 2022

Code	Description
48BUB	WINDOW, PASSENGER, TINT Conventional; 28% Light, Tempered Glass, 78" Headroom, with 34'11", 31'2", 31'11", 32'8", 33'5", 34'2", 35'8" Body Lengths
48CMY	UPHOLSTERY, DRIVER SEAT, COLOR 2-Tone Gray
48GHC	HEATER, DRIVER 90,000 BTU, with Defroster and without Rear Heat Duct <u>Includes</u> : AIR FILTER : HEATER HOSES Premium : HOSE CLAMPS, HEATER HOSE Mubea Constant Tension Clamps
48NAT	FITTINGS, AIR SEAT for Driver Seat
48PAM	WINDSHIELD 3 Flat Pieces, 73% Light, with Band
48PAV	WHEEL POCKET COVER Plastic, ABS
48PAY	AISLE POSITION Center, for balanced seating
48PEW	FLOOR COVERING, COLOR Gray #766
48PJZ	FLOOR COVERING, TYPE {Koroseal} All Body Lengths
48PKC	HOSE CLAMPS, HEATER HOSE Constant Torque for Heater System
48PKM	FLOOR COVERING, TRIM {Koroseal} Plastic Base with PVC Cap
48PKS	FAN, DEFOG RIGHT CENTER 6.50" Diameter, Black, Mounted Over Windshield, 15" Right of Centerline, 2-Speed Switch in Panel
48PMH	HEATER, PASS, LT REAR 50,000 BTU <u>Includes</u> : AIR FILTER
48PMM	HEATER, PASS, RT MIDSHIP 1ST 50,000 BTU <u>Includes</u> : AIR FILTER
48PNZ	HEATER, WATER PUMP {2 MPU 12} Self Priming, Metal Housing
48PPM	HEATER CUT OFF, VALVE Ball, with Butterfly Handle
48PPS	ROOF VENT, FRONT Static
48PTT	ARM REST, DRIVER, RIGHT {National}
48PUT	NUTS, BELT MOUNTING Standard Nuts For Seat Belt Mounting
48PVB	UPHOLSTERY, DRIVER SEAT, STYLE Plain
48PWD	UPHOLSTERY, PASS SEATS, COLOR Gray, for Seats, Barriers and Head Bumpers
48PWZ	UPHOLSTERY, DRIVER SEAT, TYPE Fabric
48PXA	UPHOLSTERY, BARRIER, TYPE (1-2) Vinyl, 42 oz.
48RAE	BARRIER, CRASH, AFT ENTRY DOOR 39", 1 Leg
48RAL	BARRIER, CRASH, AFT DRIVER 39", 1 Leg
48REP	PANEL, MODESTY, AFT OF DRIVER Mounted Under Barrier
48RET	PANEL, MODESTY, AFT ENTR DOOR Mounted Under Barrier
48RGE	HAND RAIL, ENTRANCE DOOR, FWD Stainless Steel; Curved

Vehicle Specifications
2024 INTEGRATED CE S BUS (PB105)

September 09, 2022

<u>Code</u>	<u>Description</u>
48RGR	HAND RAIL, ENTRANCE DOOR, AFT Stainless Steel, 4", Above Step
48RLX	CUSHION, SEAT 15" Depth
	<u>Includes</u> : WARRANTY Four Years
48RRA	UPHOLSTERY, SEAT, STITCHING Single
	<u>Includes</u> : WARRANTY Two Years
48SAD	SEAT,PASS,LT,26",2 LEG (01)
48SBG	UPHOLSTERY, PASS SEATS, TYPE Vinyl, 42 Ounce
48SDV	SEAT,PASS,LT,39",2 LEG (12)
	<u>Notes</u> : BTI Seating System Base Seat. Retrofittable, Contact IC Bus Application Engineering for more information.
48SKP	SEAT,PASS,RT,39",2 LEG (13)
	<u>Notes</u> : BTI Seating System Base Seat. Retrofittable, Contact IC Bus Application Engineering for more information.
48TZK	SEAT, DRIVER {National Premium} Air Suspension with Suspension Skirt, Triple Chamber Adjustable Air Lumbar, Adjustable Cushion and Back Bolsters, 6 Position Front Cushion Adjuster, 3 Position Rear Cushion Adjuster, 6 to 23 Degree Back Recline
	<u>Includes</u> : SEAT BELT, DRIVER Adjustable D-Loop Seat Belt, Single Locking Retractor
48USV	SEAT BACK, PASSENGER High Back
48UZN	ROOF HATCH, FRONT {Specialty Hybrid Adv H1975-025-191-0F} Emergency Exit with Outside Release, Alarm, English Decals
48UZT	ROOF HATCH, REAR {Specialty Hybrid Adv H1975-025-191-0F} Emergency Exit with Outside Release, Alarm, English Decals
48VVR	STEP TREADS {Koroseal} Pebble White Nosing Only, with Non-Metal Backing, used with Formed Treaded Steps
49028	BODY PLAN, APPROVED VARIATION Number 028
49AHV	LIGHT, STROBE, STOP SIGN, FRT In Lieu Of Flashing Lights Furnished with Stop Sign, Speciality
49AMD	SWITCH, DRIVER PANEL, TYPE Rocker
49AMJ	ALARM, BACKING {Ecco #575} 107 dB
49AMT	CIRCUIT, PROTECTION Breakers, Manual Reset in Lieu of Fuses
	<u>Includes</u> : ACCESS PANEL for Body and Chassis Fuses/Circuit Breakers Located on Body Exterior; Below Driver Window
49AMY	SWITCH, REAR DOOR BUZZER for Emergency Door
49ANH	SWITCH, MAGNETIC, DISCONNECT Master, Ignition Operated, All Body Circuits
49ANU	SOURCE, POWER 12 VDC, Mounted In Dash
49AUM	SWITCH, MASTER FLASHER Omit Master Flasher Switch, 8-Lamp System
49AWV	SPEAKERS AND WIRING (8) Flush Mounted In Light Bar

Vehicle Specifications
2024 INTEGRATED CE S BUS (PB105)

September 09, 2022

<u>Code</u>	<u>Description</u>
49BCL	FLASHER SYSTEM (8) Warning Lights, 8-Lamp System, Electronic Relay Flasher, Sequential Operation, Red Lights Activate after Amber Lights, with Road Speed Parameters
49BCR	LIGHT, EXTERIOR, CHECK Automatically Activates Lights for Pre Trip Inspection
49BEW	MIRROR, REAR VIEW, EXTERIOR {Mirror Lite Super Nickels} Black, Motorized Head, Heated
49BMA	STOP ARM, FRONT {Specialty 2980} Air, 18" Octagon, Double Sided, 1/2" White Border, Hi Intensity Grade, Strobing LED Lights
49BUT	VISOR, INTERIOR, LEFT FRONT 6" x 30", Transparent, For Left Windshield, with Finger Hold Adjustment Knob
49BVD	SWITCH, BATTERY Shut-Off, 300A Weather Resistant, In Battery Compartment
49BVE	MIRROR, CROSS VIEW, EXTERIOR (2) {Mirror Lite High Definition Busboy} Black
49BYT	LIGHTS, STOP (2) {Sound Off/OptiLuxx} and Tail; 7" Round LED, Red
49BYZ	LIGHTS, DIRECTIONAL, REAR (2) {Sound Off/OptiLuxx} LED, 7" Round Amber
49BZG	LIGHTS, BACK UP (2) {Sound Off/OptiLuxx} LED, 7" Round Clear
49CKT	FUEL FILLER PIPE Low Profile Neck Cap and Vent Hosing, for Use with Right Side Fill for Between the Rail Fuel Tanks, for Above the Floor Fuel Fill, for 25 GPM Fill Rate Only
49CLM	RADIO, ENTERTAINMENT AM/FM/USB Input/Auxiliary Input, Includes Antenna and Cable, with Public Address System
49DAG	LIGHT, INDIC, WARNING LIGHTS LED Type; Red and Amber
49DBR	HOOD, WARNING LAMP (4) Black, 8-Lamp System, One Hood Above Two Lights
49DDC	LIGHTS, CLUSTER {Truck Lite 07045A & 07045R} LED; Amber Front and Red Rear
49EAX	LIGHTS, DIRECTIONAL, SIDE (4) {Sound Off/OptiLuxx} Rectangular LED Armored, 2 Each Side First Section Aft Entrance Door & Forward Rear Wheel Pocket
49ENR	VISOR, INTERIOR, DRIVER LEFT 10" X 30" for Driver's Window
49ESC	LIGHTS, DOME, DRIVER {Sound Off/OptiLuxx} (1) LED, Rectangular, Mounted in Light Bar in Ceiling, with Separate Switch
49EUB	KIT, FIRST AID Metal; 24 Unit, Spec State
49EVL	SWITCH, NOISE SUPPRESSION Actuator Legend States, "NOISE SUPP ", for Separate Solenoid, with Red Switch in Panel
49GBG	KIT, BODY FLUID Arizona, Mounted on the Bulkhead
49GBV	WINDSHIELD WIPERS (2) Cowl Mounted
	<u>Includes</u> : WINDSHIELD WIPERS CONTROL Single Motor, Overlapping Wipe Pattern
49GDG	PADDING COMPART ABOVE DRIVER Window; Safety Equipment Compartment, with Cutout for Dome Light
49GDS	COMPARTMENT ABOVE DRIVER Left of the Driver
	<u>Includes</u> : COMPARTMENT ABOVE DRIVER Compartment Size: 39" x 10" x 10" : HINGES Piano Type
49GGE	FIRE EXTINGUISHER, DRIVER AREA 5 lb 2A-40BC Minimum, with Flexible Hose and Metal Nozzle
49GHN	REFLECTORS, REAR (2) 3", Red, Adhesive Back
49GHR	REFLECTORS, SIDE, REAR (2) 3", Red, Adhesive Back

Vehicle Specifications
2024 INTEGRATED CE S BUS (PB105)

September 09, 2022

Code	Description
49GHV	REFLECTORS, SIDE, FRONT (2) 3", Amber; Adhesive Back, 1 Aft Drivers Window Left, 1 Aft Entrance Door Right
49GHX	REFLECTORS, SIDE, INTERMEDIATE (2) 3" Amber, 1 Each Side, Below The Third Rub Rail From the Top, Adhesive Back
49GKL	SAFETY TRIANGLES 1 Kit; Warning Reflectors, Mounted on Floor Between Driver Seat and Drivers Crash Barrier/Stanchion
49GKZ	FUEL FILLER DOOR with Non-Locking Latch
49GUK	FENDERS, RUBBER, REAR (2)
49GUM	INSPECTION PLATE Fuel Sending Unit 8" x 8" Steel
49GUX	MUD FLAPS, FRONT WHEELS (2) Rubber
49GVH	MUD FLAPS, REAR WHEELS (2) Brackets Only
49GWW	WINDSHIELD WASHER Kit; 6 Quart Capacity, Bottle <u>Includes</u> : WINDSHIELD WASHER ELECTRICAL CONNECTIONS Sealed and Locking Type
49JAD	DEF FILLER DOOR with Locking Latch
49JBP	LIGHTS, DOME {Sound Off/OptiLuxx} (07) LED, Rectangular Recessed Type, Mounted in Light Bar
49JBU	LIGHT, ENTRY DOOR {Sound Off/OptiLuxx} LED; 4" Oval; Light Mounted in Skirt Behind Entrance Door, Wired To Step Light
49JBX	LIGHT, STEP {Sound Off/OptiLuxx} 4" Round LED, White, Wired to Ignition, Operated by Entrance Door
49JBY	LIGHTS, MARKER, FRONT & REAR (4) {Sound Off/OptiLuxx} LED, Armored, Slim-Line, (2) Amber Front and (2) Red Rear
49MRN	MIRROR, INSIDE 6" x 30" with Lever Lock
49MZV	LATCH, COMPARTMENT Locking, for Overhead Storage Compartment
49NGB	LIGHT, COMPARTMENT, ENGINE {Sound Off/OptiLuxx} LED 4" Oval; Activated with Parking Lights, with On/Off Switch, Includes Limit Switch that Allows Light to come on When Hood is Opened
49NGG	LIGHTS, TAIL, LICENSE PLATE (2) {Sound Off/OptiLuxx} 4" Round LED, Red, Includes Stop & Light Window, Includes Mounting Gasket
49NGJ	LIGHTS, WARNING (8) {Sound Off/OptiLuxx} (4) 7" Round Red Strobing LED and (4) 7" Round Amber Strobing LED, 2 Front, 2 Rear Each Color
49UAC	STATE OF OPERATION Arizona
49ZNE	LIGHTS, MARKER, SIDE, INTERMED {Sound Off/OptiLuxx} LED, Amber, Slim-Line, Armored, Intermediate, Centered, Required for Units 30 Foot or Longer
50ACW	BODY PLAN, NON-SPECIAL NEEDS Conventional; 34' 11" Body Length, +9 Section Rear, 77 Passenger, 276" WB, DX3071A000
7382135415	(2) TIRE, FRONT 11R22.5 Load Range H HSR2 (CONTINENTAL), 498 rev/mile, 75 MPH, All-Position
7382135415	(4) TIRE, REAR 11R22.5 Load Range H HSR2 (CONTINENTAL), 498 rev/mile, 75 MPH, All-Position
Services Section:	
40126	WARRANTY Standard for CE, RE, BE School Bus Models, Effective with Vehicles Built March 1, 2017 or Later, CTS-3304H

Vehicle Specifications
2024 INTEGRATED CE S BUS (PB105)

September 09, 2022

<u>Code</u>	<u>Description</u>
40PLB	SRV CONTRACT, EXT VEH COVERAGE {Navistar} To 36-Month/50,000 Miles (80,000 km), Covers 100% Parts and Labor; Includes Body; Excludes Extending Warranty for Engine, Transmission, Perforation or Corrosion of Cab/Cowl Structure and Paint
40RAT	SERVICES, TOWING {Navistar} Service Call to 60-Month/Unlimited Mileage to the Nearest IC Bus Dealer for Navistar Warrantable Failure as Contract Defined; Includes Engine Failure if Supplier Declines Tow Coverage & ESC Supplied thru Navistar; \$1100 (USA) Maximum Benefit per Incident
49GVN	WARRANTY 5-Year, Limited
Body/Allied Equipment	
<u>Code</u>	<u>Description</u>
Goods Purchased	
<u>Code</u>	<u>Description</u>

Turning Radius Summary
2024 INTEGRATED CE S BUS (PB105)

September 09, 2022

Series: INGB
 Model: PB105
 Description: INTEGRATED CE S BUS
 Model Year: 2024

Calculation Factors

Wheelbase: 276
 Front Axle: 0002ASH
 Description: AXLE, FRONT NON-DRIVING, (Meritor MFS-10-122A) I-Beam Type, 10,000-lb Capacity
 Front Wheel: 0027DUW
 Description: WHEELS, FRONT, {Accuride 51408} DISC; 22.5x8.25 Rims, Powder Coat Steel, 2-Hand Hole, 10-Stud, 285.75mm BC, Hub-Piloted, Flanged Nut, with Steel Hubs
 Front Tire: 07382135415
 Description: TIRES, 11R22.5 Load Range H HSR2 (CONTINENTAL), 498 rev/mile, 75 MPH, All-Position
 Steering Gear: 0005PRR
 Description: STEERING GEAR, (TRW (Ross) TAS66) Power

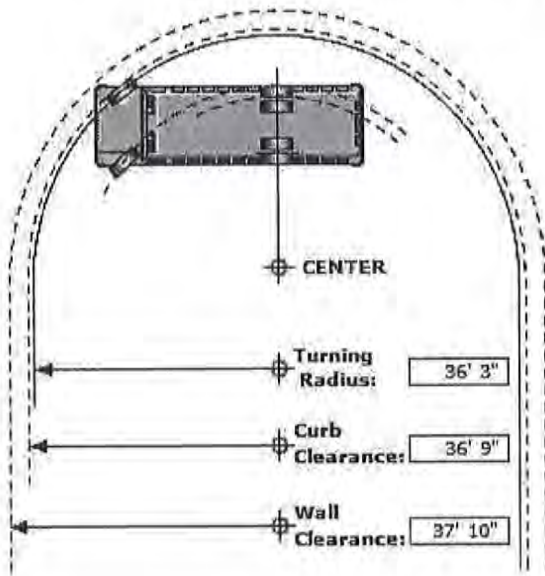

Turning Radius Statistics

General Information

Inside Turn Angle: 50 Degrees
 Radial Overhang: 19

Axle Information

KingPin Inclination: 6.25 Degrees
 KingPin Center: 69

Turning Radius - Curb View

C	- Curb Contact Length:	15.91
CI	- Curb Clearance Increment:	5.84
CR	- Curb Clearance Radius:	36'9"
CH	- Curb Height:	6"
TR	- Turning Radius:	36'3"
TW	- Tire Width:	11.10

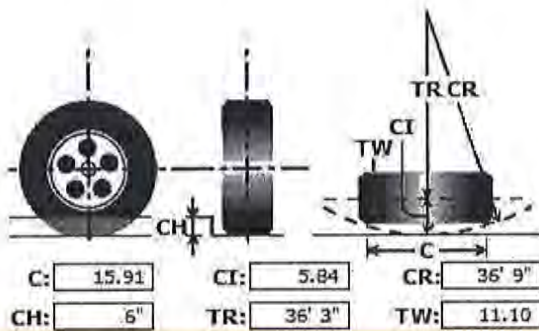

* All Measurements are in inches, unless otherwise specified.

This information is based on engineering information available at this time. Actual figures may vary. Navistar, Inc. cannot accept liability for consequences due to this variance.

Date: 3/10/23
 Quote Valid Until:
 Prepared By: TOM HARTMAN



Name:
 Organization: EQUALIS GROUP
 Address:
 City, State ZIP:
 Phone:

YEAR:	2024
MAKE:	IC
MODEL:	CE CUMMINS DIESEL
CAPACITY:	44 PASS SPECIAL NEEDS
STOCK #'S:	RWCICCED-3

		INCLUDES 3 CAMERA SYSTEM AND DVR INCLUDES AC SYSTEM EV FREEBLOW	\$ 219,000.00
TRADE BUS #:		Trade Total:	\$ -
		Pre Tax Sub Total:	\$ 219,000.00
		Sales Tax ():	\$ -
		Local Delivery Charge:	\$ 0
		TOTAL PRICE:	\$ 219,000.00

RWC BCEE-3 44pass Special Needs
Cummins Diesel

September 09, 2022

Prepared For:
RWC International Ltd
TOM HARTMAN
2202 S Central Ave.
Phoenix, AZ 85004-2908
(602)307 - 1050
Reference ID: C2608-218-44V*

Presented By:
RWC Group
Julie Shockley
600 North 75th Avenue
PHOENIX AZ 85043 -
(602)307-1050

Model Profile
2024 INTEGRATED CE S BUS (PB105)

APPLICATION: School Transportation, Special Needs
MISSION: Requested GVWR: 28280. Calc. GVWR: 28280
Calc. Start / Grade Ability: 26.91% / 2.31% @ 55 MPH
Calc. Geared Speed: 88.4 MPH

DIMENSION: Wheelbase: 217.00, CA: N/A, Axle to Frame: 126.00
ENGINE, DIESEL: {Cummins B6.7 260} EPA 2021, 260HP @ 2400 RPM, 660 lb-ft Torque @ 1600 RPM, 2600 RPM
Governed Speed, 260 Peak HP (Max), School Bus Only

TRANSMISSION, AUTOMATIC: {Allison 2500 PTS} 6th Generation Controls, Wide Ratio, 6-Speed with Double Overdrive, Less
PTO Provision, Less Retarder, with 33,000-lb GVW and GCW Max, School Bus

CLUTCH: Omit Item (Clutch & Control)

AXLE, FRONT NON-DRIVING: {Dana Spicer D-800F} I-Beam Type, 8,000-lb Capacity
AXLE, REAR, SINGLE: {Dana Spicer S140} Single Reduction, 21,000-lb Capacity, 190 Wheel Ends Gear Ratio: 4.88
TIRE, FRONT: (2) 255/70R22.5 Load Range H HSR2 SA (CONTINENTAL), 565 rev/mile, 75 MPH, All-Position
TIRE, REAR: (4) 255/70R22.5 Load Range H HSR2 SA (CONTINENTAL), 565 rev/mile, 75 MPH, All-Position
SUSPENSION, REAR, AIR, SINGLE: {International IROS} 21,000-lb Capacity, 9.25" Ride Height, with Shock Absorbers

PAINT: Cab schematic 272NB
Location 1: 4421, School Bus Yellow (Std)
Location 2: 4422, School Bus Yellow Non Reflective (Nrf)
Chassis schematic N/A

Vehicle Specifications
2024 INTEGRATED CE S BUS (PB105)

September 09, 2022

<u>Code</u>	<u>Description</u>
PB10500	Base Chassis, Model INTEGRATED CE S BUS with 217.00 Wheelbase, N/A CA, and 126.00 Axle to Frame.
1570	TOW HOOK, FRONT (2) Frame Mounted
1CAC	FRAME RAILS High Strength Low Alloy Steel (50,000 PSI Yield); 10.125" x 3.062" x 0.312" (257.2mm x 77.8mm x 8.0mm); 489.2" (12425mm) Maximum OAL <u>Includes</u> : CHASSIS PAINT Chassis Painted Prior to Body Mounting : FRAME RAILS All holes Laser Aligned and Machine Punched, Powder Coated Prior to Full Assembly, Assembled in Fixture using "Grade 8" Bolts : FRAME REINFORCEMENT, SPECIAL 3.30" x 1.80" x 0.312" x 31.50" Inverted "L" in Front Shock Absorber Mounting Area
1LLE	BUMPER, FRONT Contoured, Steel, Severe Duty <u>Includes</u> : BUMPER, FRONT THICKNESS 1/4 Inch
1LNT	CROSSING GATE, FRONT Omit Item <u>Includes</u> : CROSSING GATE, FRONT Matches Contour of Bumper
1SAM	CROSSMEMBER, REAR, AF (2)
1WHT	WHEELBASE RANGE 193" (490cm) Through and Including 217" (550cm)
2AEM	AXLE, FRONT NON-DRIVING {Dana Spicer D-800F} I-Beam Type, 8,000-lb Capacity <u>Includes</u> : AXLE, FRONT SQUARING to Plus or Minus .015 Inch, using a Special Fixture to Assure Parallelism of Springs <u>Notes</u> : The following features should be considered when calculating Front GAWR: Front Axles; Front Suspension; Brake System; Brakes, Front Air Cam; Wheels; Tires.
3ADA	SUSPENSION, FRONT, SPRING Parabolic Taper Leaf, Shackle Type, 8,000-lb Capacity, with Shock Absorbers <u>Includes</u> : SPRING PINS Bolt and Nut Type <u>Notes</u> : The following features should be considered when calculating Front GAWR: Front Axles; Front Suspension; Brake System; Brakes, Front Air Cam; Wheels; Tires.
4091	BRAKE SYSTEM, AIR Dual System for Straight Truck Applications <u>Includes</u> : BRAKE LINES Color and Size Coded Nylon : DRAIN VALVE Twist-Type : GAUGE, AIR PRESSURE (2) Air 1 and Air 2 Gauges; Located in Instrument Cluster : PARKING BRAKE CONTROL Yellow Knob, Located on Instrument Panel : PARKING BRAKE VALVE For Truck : QUICK RELEASE VALVE On Rear Axle for Spring Brake Release: 1 for 4x2, 2 for 6x4 : SPRING BRAKE MODULATOR VALVE R-7 for 4x2, SR-7 with relay valve for 6x4/8x6 <u>Notes</u> : Rear Axle is Limited to 19,000-LB GAWR with Code 04091 BRAKE SYSTEM, AIR and Code 04NDC BRAKES, REAR, AIR CAM Regardless of Axle/Suspension Ordered : Rear Axle is Limited to 20,000-LB GAWR with Code 04092 BRAKE SYSTEM, AIR and Code 04NCW BRAKES, REAR, AIR CAM Regardless of Axle/Suspension Ordered

Vehicle Specifications
2024 INTEGRATED CE S BUS (PB105)

September 09, 2022

<u>Code</u>	<u>Description</u>
4AZS	AIR BRAKE ABS (Bendix AntiLock Brake System) 4-Channel (4 Sensor/4 Modulator) Electronic Stability Program, with Automatic Traction Control
4EBT	AIR DRYER (Bendix AD-IP) with Heater
4EXP	BRAKE CHAMBERS, FRONT AXLE (Bendix) 20 Sqn
4EXU	BRAKE CHAMBERS, REAR AXLE (Bendix EverSure) 30/30 Sqn Spring Brake
4GBM	BRAKE, PARKING Manual Push-Pull Pneumatic Parking Brake
4LAG	SLACK ADJUSTERS, FRONT (Gunite) Automatic
4LGG	SLACK ADJUSTERS, REAR (Gunite) Automatic
4SPA	AIR COMPRESSOR (Cummins) 18.7 CFM
4WEA	PARKING BRAKE INTERLOCK Parking Brake Cannot be Released Until Ignition Switch is in "On" Position and Service Brake Pedal is Applied, Use with Air Brake Chassis Only
4WWX	DRAIN VALVE (Humphrey) (3) Air Operated, with Controls in Drivers Compartment, for Air Tanks
4WZT	GVWR LIMITATION FOR BUS with Air Brakes, Limited to 33,000-lbs Maximum to meet FMVSS 121 Requirements, for Conventional Bus
4XDD	BRAKES, FRONT (Meritor 15X5 Q-PLUS CAST) Air S-Cam Type, Cast Spider, Fabricated Shoe, Double Anchor Pin, Size 15" X 5", 13,200-lb Capacity
4XDR	BRAKES, REAR (Meritor 16.5X7 Q-PLUS CAST) Air S-Cam Type, Cast Spider, Fabricated Shoe, Double Anchor Pin, Size 16.5" X 7", 23,000-lb Capacity per Axle
5710	STEERING COLUMN Tilting and Telescoping
5CAL	STEERING WHEEL 2-Spoke, 18" Dia., Black
5PRG	STEERING GEAR (TRW (Ross) TAS40) Power
6DGA	DRIVELINE SYSTEM (Dana Spicer) SPL100, for 4x2/6x2
7BMK	EXHAUST SYSTEM Horizontal Aftertreatment System, Frame Mounted Under Right Rail, for Single Long Horizontal Tail Pipe
7WBL	TAIL PIPE (1) Horizontal, Long, Exits Left Side Through Bumper
8000	ELECTRICAL SYSTEM 12-Volt, Standard Equipment
	<u>Includes</u>
	: HAZARD SWITCH Push On/Push Off, Located on Top of Steering Column Cover
	: HEADLIGHT DIMMER SWITCH Integral with Turn Signal Lever
	: MISCELLANEOUS FEATURES Modular, Loom Protected, Grommets in all Applicable Body Openings, Assembled in Computer Assisted Fixture which Verifies Continuity and Correct Assembly Prior to Installation
	: PARKING LIGHT Integral with Front Turn Signal and Rear Tail Light
	: STARTER SWITCH Electric, Key Operated
	: TURN SIGNAL FLASHER
	: TURN SIGNAL SWITCH Self-Cancelling with Lane Change Feature
	: TURN SIGNALS, FRONT Includes Reflectors; Flush Mounted
	: WINDSHIELD WIPER SWITCH 2-Speed with Wash and Intermittent Feature (5 Pre-Set Delays), Integral with Turn Signal Lever
	: WIRING, CHASSIS Color Coded and Continuously Numbered
8541	HORN, ELECTRIC (2) Disc Style
8GXK	ALTERNATOR (Leece-Neville BLP4006HN) Brushless, 12 Volt, 325 Amp Capacity, Pad Mount, with Remote Sense
8MSG	BATTERY SYSTEM (Fleetrite) Maintenance-Free, (3) 12-Volt 1980CCA Total, Top Threaded Stud

Vehicle Specifications
2024 INTEGRATED CE S BUS (PB105)

September 09, 2022

<u>Code</u>	<u>Description</u>
8TTK	BATTERY BOX Steel, with Sliding Tray, 25.25" Wide, for Standard Batteries, 1-3 Battery Capacity, Mounted Left Side Behind Front Axle Perpendicular to Frame Rail
8TUT	COLLISION MITIGATION SYSTEM Omit
8WPB	HEADLIGHTS Halogen, Composite Aero Design, with Daytime Running Lights
8WTK	STARTING MOTOR {Delco Remy 38MT Type 300} 12 Volt, Less Thermal Over-Crank Protection
8WWJ	INDICATOR, LOW COOLANT LEVEL with Audible Alarm
8WXB	HEADLIGHT WARNING BUZZER Sounds When Head Light Switch is on and Ignition Switch is in "Off" Position
8XAH	CIRCUIT BREAKERS Manual-Reset (Main Panel) SAE Type III with Trip Indicators, Replaces All Fuses
9AAE	LOGOS EXTERIOR, ENGINE Badges
9WAB	HOOD TILT ASSIST {EASY TILT} Mechanical
9WAY	FRONT END Tilting, Fiberglass, with Three Piece Construction
	<u>Includes</u> : AIR INTAKE SYSTEM Integrated Pre-Cleaning System to Enhance Air Filter Life : GRILLE Removable; Fiberglass Painted Hood Color : SPLASH SHIELD Integral with Front End Assembly
10020	CHASSIS PAINT Full Chassis
10072	PAINT SCHEMATIC, PT-1 Two Tone, Design 272.
10661	PAINT, NON-REFLECTING Non-Reflecting Paint
10788	PAINT TYPE Urethane, One or Two Colors, Other than Imron or International.
10AA Y	OVER THE AIR PROGRAMMING {Navistar} for Cummins Engines
10XAK	PROMOTIONAL PACKAGE 7 Year Unlimited Miles/km Warranty, Limited Time Program for Allison 2500 Series Transmission on School and Commercial Buses (Supplied directly through Allison)
11001	CLUTCH Omit Item (Clutch & Control)
12703	ANTI-FREEZE Red, Extended Life Coolant; To -40 Degrees F/ -40 Degrees C, Freeze Protection
12ERU	ENGINE, DIESEL {Cummins B6.7 260} EPA 2021, 260HP @ 2400 RPM, 660 lb-ft Torque @ 1600 RPM, 2600 RPM Governed Speed, 260 Peak HP (Max), School Bus Only
12TSY	FAN DRIVE {Borg-Warner SA85} Viscous Type, Screw On
	<u>Includes</u> : FAN Nylon
12UGN	THROTTLE, HAND CONTROL Electronic
	<u>Notes</u> : Cruise Control Switches Mounted on Steering Wheel are Non-Illuminated.
12UYE	RADIATOR Aluminum, 2-Row, Cross Flow, Over Under System, 717 SqIn Louvered, with 313 SqIn Charge Air Cooler, Includes In-Tank Oil Cooler
	<u>Includes</u> : DEAERATION SYSTEM with Surge Tank : HOSE CLAMPS, RADIATOR HOSES Gates Shrink Band Type; Thermoplastic Coolant Hose Clamps : RADIATOR HOSES Premium, Rubber
12VBR	AIR CLEANER with Service Protection Element
	<u>Includes</u>

Vehicle Specifications
2024 INTEGRATED CE S BUS (PB105)

September 09, 2022

<u>Code</u>	<u>Description</u>
	: GAUGE, AIR CLEANER RESTRICTION Air Cleaner Mounted
12VJB	EMISSION, CALENDAR YEAR {Cummins B6.7} EPA, OBD and GHG Certified for Calendar Year 2022
12VVN	CRUISE CONTROL Electronic
	<u>Notes</u>
	: Cruise Control Switches Mounted on Steering Wheel are Non-Illuminated.
12VWH	GOVERNOR Electronic Road Speed Type; for Electronic Engines and Bus Models; with 55 MPH Default
12VYV	IDLE MANAGEMENT SYSTEM Ramp Engine Speed with Air Condition On, in Neutral and Parking Brake Set, Accommodation Package
12WAE	HOSE CLAMPS, RADIATOR HOSES Constant Torque, for Engine Hoses 1.0" I.D. and Over
12WSY	BLOCK HEATER, ENGINE {Phillips} 120V/750W, for Cummins ISB/B6.7 Engines
12WZE	CARB IDLE COMPLIANCE Federal, Does Not Comply with California Clean Air Idle Regulations
12XCS	CARB EMISSION WARR COMPLIANCE Federal, Does Not Comply with CARB Emission Warranty
13BBP	TRANSMISSION, AUTOMATIC {Allison 2500 PTS} 6th Generation Controls, Wide Ratio, 6-Speed with Double Overdrive, Less PTO Provision, Less Retarder, with 33,000-lb GVW and GCW Max, School Bus
13WLN	TRANSMISSION OIL Synthetic; 20 thru 28 Pints
13WVW	NEUTRAL AT STOP OMIT
13WYY	SHIFT CONTROL PARAMETERS {Allison} 1000 or 2000 Series Transmissions, Performance Programming
14AKC	AXLE, REAR, SINGLE {Dana Spicer S140} Single Reduction, 21,000-lb Capacity, 190 Wheel Ends . Gear Ratio: 4.88
14TBS	SUSPENSION, REAR, AIR, SINGLE {International IROS} 21,000-lb Capacity, 9.25" Ride Height, with Shock Absorbers
	<u>Notes</u>
	: The following features should be considered when calculating Rear GAWR: Rear Axles; Rear Suspension; Brake System; Brakes, Rear Air Cam; Brake Shoes, Rear; Special Rating, GAWR; Wheels; Tires.
14WAW	FLAT FLOOR EFFECTS for Air Suspension; with Conventional Bus Models
15SZM	FUEL TANK Top Draw, Steel, Rectangular, 65 US Gal (246L), Includes Protective Cage, for Low Profile Fuel Filler Assembly and Vent Hosing, Mounted Between Frame Rails and Behind Rear Axle
15WEP	DEF TANK 16.5 US Gal (62.5L) Capacity, Frame Mounted Outside Right Rail, Behind 0 Bow
16010	COWL Flat Back
16HBA	GAUGE CLUSTER English with English Electronic Speedometer
	<u>Includes</u>
	: GAUGE CLUSTER (5) Engine Oil Pressure (Electronic), Water Temperature (Electronic), Fuel (Electronic), Tachometer (Electronic), Voltmeter
	: ODOMETER DISPLAY, Miles, Trip Miles, Engine Hours, Trip Hours, Fault Code Readout
	: WARNING SYSTEM Low Fuel, Low Oil Pressure, High Engine Coolant Temp, and Low Battery Voltage (Visual and Audible)
16HGH	GAUGE, OIL TEMP, AUTO TRANS for Allison Transmission
16HHE	GAUGE, AIR CLEANER RESTRICTION {Filter-Minder} with Black Bezel, Mounted in Instrument Panel
16HKT	IP CLUSTER DISPLAY On Board Diagnostics Display of Fault Codes in Gauge Cluster
16HLJ	GAUGE, DEF FLUID LEVEL

Vehicle Specifications
2024 INTEGRATED CE S BUS (PB105)

September 09, 2022

<u>Code</u>	<u>Description</u>
16VCD	DASH INSULATOR
27DUW	WHEELS, FRONT (Accuride 51408) DISC; 22.5x8.25 Rims, Powder Coat Steel, 2-Hand Hole, 10-Stud, 285.75mm BC, Hub-Piloted, Flanged Nut, with Steel Hubs
28DUW	WHEELS, REAR (Accuride 51408) DUAL DISC; 22.5x8.25 Rims, Powder Coat Steel, 2-Hand Hole, 10-Stud, 285.75mm BC, Hub-Piloted, Flanged Nut, with Steel Hubs
47AEU	BODY, BUS Conventional; 78" Headroom, 26'8" Body Length, +9 Section Front and Rear, 54 Passenger, 217/218 WB
47AJC	BODY TAG, METAL Capacity to Include the Total Number of Passengers
47APR	HEADLINER, BODY Conventional; 25'11"-35'08" Body Length, Perforated Full Length with Sound Insulation Full Length
47APW	FASTENERS, HEADLINER Rivets
47ARH	BOWS, ROOF 14 ga., One Piece Construction
	<u>Includes</u> : BOWS, ROOF Positioned Floor Line to Floor Line, Threaded Through Roof Strainers and Drip Rail
47ARP	LIGHT BARS Plastic
47ASZ	SKIRT, BODY Conventional, 20", 16ga., 25'2", 25'11", 26'8", 27'5" Body Length
	<u>Includes</u> : SKIRT, BODY Extra Smooth Steel Supported by Floor Gussets
47AUR	TIE DOWNS, BODY Grade 8 Bolts, Every Body Section
	<u>Includes</u> : TIE DOWNS, BODY with Formed Tab that Fits into Floor Structure to Prevent Turning
47AXR	RUB RAILS, BODY (4) Conventional; Steel, 25'2", 25'11", 26'8", 27'5" Body Length, Includes Snow Rail
	<u>Includes</u> : RUB RAILS Full Length, Primer Coated (Both Sides), Attached to Body without Cuts or Splices
47AYB	BODY, REAR Includes Emergency Door
	<u>Includes</u> : DOOR, REAR EMERGENCY with Concealed Hinges : HEADER BUMPER Padded, Mounted Over Rear Door; Upholstered to Match Passenger Seat Color
47AZC	SIDE SHEET, BODY, EXTERIOR Conventional, 16ga., Smooth, 25'2", 25'11", 26'8", 27'5", Body Length
47AZK	FLOOR, BODY Flat
47AZX	RAILS, WRAP-AROUND, FLOOR At Floor Level To Rear Door Post
47AZZ	RAILS, WRAP-AROUND Just Below Window Line
47BAK	BUMPER, REAR Painted, 12" High, 3/16" Thick
47BAR	SUPPORTS, REAR BUMPER Bolted to Frame
47BAW	TOW HOOK, LEFT REAR (01)
47BAX	TOW HOOK, RIGHT REAR (01)
47BBH	LINING, SIDE INTERIOR, LOWER Embossed Steel, Clear Coated
47BBZ	SEALER Extra; Sidewall to Floor, In Wheel Pocket Area, and Rear Wall to Floor
47BLE	STEP, FRONT ENTRANCE DOOR 25 3/4" Depth; 14ga Steel, Formed Treads, Naviflex Finish

Vehicle Specifications
2024 INTEGRATED CE S BUS (PB105)

September 09, 2022

<u>Code</u>	<u>Description</u>
47DAJ	COVER, REAR DOOR INSIDE HANDLE Partial Coverage
47DAK	FASTENERS, REAR DOOR Bolts and Nutserts, Rear Door To Body
47DBP	DOOR, ENTRANCE, FRONT Air, Outward Opening, with Split Pane Glass
47DCW	HANDLE, EXTERIOR, LIFT DOOR Single Door, Yellow
47DDE	HANDLE, ASSIST, ENTRANCE DOOR Outside Entrance
47DDH	HOLD BACK, REAR DOOR Stationary, No Cables, with Plastic Cover
47DDR	LATCH, LIFT DOOR Single, Three Point Slide Bar
47DDU	LATCH, REAR DOOR One Point Slide Bar, Cam Operated, with One Inch Stroke
47DEK	LOCK, REAR DOOR with Ignition Starter Interlock
47DEV	LOCK, SINGLE LIFT DOOR with Ignition Starter Interlock
47DEY	HANDLE, EXTERIOR, REAR Emergency Door; Yellow
47DNK	SWITCH, LOCATION Steering Wheel; Includes Master Flasher, Flasher On/Off, Red Override, and Door Control
	<u>Includes</u> : SWITCH, STEERING WHEEL, LIGHT Includes Illuminated Switches
47DWP	DOOR, LIFT Single, 43" x 69.79", Mounted Aft of Rear Wheel Pocket, with 78" Headroom
47DWV	KEYS ALIKE, LOCKS Entrance Door, 545 Keys
47EBM	HOLD DOWN, BATTERY For (2) Standard Size Batteries
47EXK	LOCK, ENTRANCE DOOR Integrated Manual Control in Door, with Key
47EYD	COMPARTMENT, TOOLBOX, LT MID 13" x 15" x 25.5", with Lock
47KDC	MONITOR, POST TRIP INSPECTION {Leave No Student Behind} Accessory Controlled, with Push Button Alarm Disable at Rear of Bus in Light Bar Prompts Driver to Walk to Back of Bus to Disable Alarm
47LAR	NOISE REDUCTION, ROOF BOW Conventional; Insulation, 25'2", 25'11", 26'8", 27'5" Body Lengths
47LAU	INSULATION, ROOF/SIDES/BULKHEAD 1.5"
47MBA	UNDERCOAT, BODY Fire Resistant, Water Based, TT-C-730 Spec
	<u>Includes</u> : UNDERCOATING Performed Before and After Mounting on Chassis
47MJR	LETTERS, DOOR, REAR Decals; "EMERGENCY DOOR", 2" Black Letters Inside and Outside
47MKT	DECAL, HANDICAP (2) 6" x 6", Rear Door Between Top and Bottom Glass, and on Right Front Below Windshield
47MNM	LETTERS, BATTERY COMPARTMENT (01) Decal; "Battery"; 2" Black Letters, Centered on Standard Battery Box
47MPD	LETTERS, SCHOOL BUS FRONT/REAR Decal; "SCHOOL BUS"; with 8" Black Reflective Letters On Front and Rear Cap
47MSA	STRIPING, PERIMETER, REAR Emergency Door, 1" Yellow Reflective
47MSE	STRIPING, REAR END 2" Yellow
47MSJ	STRIPING, ROOF HATCH, FRONT Decal, Perimeter, 1" Yellow
47MSS	STRIPING, SEATLINE 2" Yellow

Vehicle Specifications
2024 INTEGRATED CE S BUS (PB105)

September 09, 2022

<u>Code</u>	<u>Description</u>
47MTY	WIRING DIAGRAM Schematic, Electrical <u>Includes</u> : ACCESS PANEL for Wiring Diagram Schematic Located on Body Exterior; Below Driver Window
47MVA	LETTERS, HEADER Decal; "WATCH YOUR STEP", 1" Black, Above Windshield
47MVC	LETTERS, STEPWELL Decal, "WATCH YOUR STEP", 2.5" Black, Behind Door on Step Riser
47NAB	PAINT COLOR, RUB RAILS 0001 Canyon Black
47NGT	PAINT HOOD TOP 4422 Yellow, Non-Reflecting
47NGW	SEAL, RUB RAILS Top Edge, All Rails
47NJA	PAINT COLOR, BODY EXTERIOR 4421 School Bus Yellow
47NJM	PAINT FLASHER BACKGRD 0001 Canyon Black
47NJS	PAINT COLOR, BUMPER Rear, 0001 Canyon Black
47NKD	PAINT COLOR, ROOF 9219 Winter White, Beginning 5" Above Drip
47NKL	PAINT, RUB RAIL Flange to Flange
47NKM	PAINT COLOR, BODY INTERIOR 9384 Spring White
47NKZ	LETTERS, FUEL I.D. Decal; "DIESEL FUEL", 2" Black, Adjacent to Fuel Filler Door
47NMG	OPERATING INSTR, REAR Decal, Inside Rear Emergency Door
47NNA	LETTERS, E/E WINDOW, LEFT (01) Decal Set, "EMERGENCY EXIT", Black Inside and Outside
47NNY	LETTERS, E/E WINDOW, RIGHT (01) Decal Set, "EMERGENCY EXIT", Black, Inside and Outside
47NRN	STRIPING, E/E WINDOW, LEFT (01) Perimeter, 1" Yellow
47NRT	STRIPING, E/E WINDOW, RIGHT (01) Perimeter, 1" Yellow
47NTE	LOGO, ROOF LINE Decal; Wing and Shield, First Body Section, Above Driver Window and Entrance Door Over Driver Window and Entrance Door
47PAR	BODY CERTIFICATION TAG Mylar Label, with Actual Tire Load Rating
47PCG	HANDLE, ASSIST Windshield Side Mounted, Left and Right, Body Color, with Certain Mirrors Only
47PLX	LETTERS, DEF, I.D. Decal; "DEF ONLY", 1" Black, on DEF Filler Door
47SBP	SUB FLOOR, PLYWOOD Conventional; B-C Exterior Grade, Less Sealed Edges, 5/8", 5 Ply, for 25'2", 25'11", 26'8" or 27'5" Body Lengths
48ACN	SEAT BELT, DRIVER, COLOR with Blaze Orange Seat Belt Webbing
48ANT	WINDOW, DRIVER Laminated, Clear
48APL	WINDOW, STOPS 12" Opening, Only with 78" Headroom
48ARG	WINDOW, SASH (11) 27" Sections, 9"x 23" Opening
48ASR	WINDOW, SASH +9 SECTIONS (3) 9" x 32 1/4" Opening
48BAG	WINDOW, E/E, LEFT (01) Vertical Hinge
48BJA	COLOR, WINDOW FRAME, PASS Passenger Window, Natural Aluminum Finish
48BKN	WINDOW, E/E, RIGHT (01) Vertical Hinge
48BTX	WINDOW, PASSENGER, TINT Conventional; 28% Light, Tempered Glass, 78" Headroom, with 25'2", 25'11", 26'8", 27'5" Body Lengths

Vehicle Specifications
2024 INTEGRATED CE S BUS (PB105)

September 09, 2022

Code	Description
48CMY	UPHOLSTERY, DRIVER SEAT, COLOR 2-Tone Gray
48GHC	HEATER, DRIVER 90,000 BTU, with Defroster and without Rear Heat Duct
	<u>Includes</u>
	: AIR FILTER
	: HEATER HOSES Premium
	: HOSE CLAMPS, HEATER HOSE Mubea Constant Tension Clamps
48GZA	AIR CONDITIONER, DASH IC Air, 40,000 BTU, Stand-Alone Dash Air Evaporator, Radiator Mounted Condenser & 13CID Compressor in Primary Drive Location, EC4.0 Control System
48GZK	AIR CONDITIONER, BODY IC Air, 120,000 BTU, Evaporators FM55 Front & Rear Flush Mounted, Condensers SMC3L Skirt Mounted, Compressor TM43, with EC4.0 Control System
48NAT	FITTINGS, AIR SEAT for Driver Seat
48PAM	WINDSHIELD 3 Flat Pieces, 73% Light, with Band
48PAY	AISLE POSITION Center, for balanced seating
48PEW	FLOOR COVERING, COLOR Gray #766
48PJR	FLOOR COVERING, TRIM Aluminum
48PJZ	FLOOR COVERING, TYPE {Koroseal} All Body Lengths
48PKC	HOSE CLAMPS, HEATER HOSE Constant Torque for Heater System
48PKR	FAN, DEFOG LEFT CENTER 6.50" Diameter, Black, Mounted Left of Center Post, 2-Speed Switch in Panel
48PMC	HEATER, PASS, LT MIDSHIP 1ST 50,000 BTU
	<u>Includes</u>
	: AIR FILTER
48PNS	KICK GUARD, MIDSHIP, LT 1ST for 50,000 BTU Passenger Heater
48PNZ	HEATER, WATER PUMP {2 MPU 12} Self Priming, Metal Housing
48PPM	HEATER CUT OFF, VALVE Ball, with Butterfly Handle
48PPS	ROOF VENT, FRONT Static
48PTT	ARM REST, DRIVER, RIGHT {National}
48PUT	NUTS, BELT MOUNTING Standard Nuts For Seat Belt Mounting
48PVB	UPHOLSTERY, DRIVER SEAT, STYLE Plain
48PWD	UPHOLSTERY, PASS SEATS, COLOR Gray, for Seats, Barriers and Head Bumpers
48PWZ	UPHOLSTERY, DRIVER SEAT, TYPE Fabric
48PXA	UPHOLSTERY, BARRIER, TYPE (1-2) Vinyl, 42 oz.
48RAE	BARRIER, CRASH, AFT ENTRY DOOR 39", 1 Leg
48RAL	BARRIER, CRASH, AFT DRIVER 39", 1 Leg
48RET	PANEL, MODESTY, AFT ENTR DOOR Mounted Under Barrier
48RGE	HAND RAIL, ENTRANCE DOOR, FWD Stainless Steel; Curved
48RGR	HAND RAIL, ENTRANCE DOOR, AFT Stainless Steel, 4", Above Step
48RHV	PANEL, MODESTY, AFT OF DRIVER Mounted Under Barrier, with Holes for Air Circulation
48RLX	CUSHION, SEAT 15" Depth

Vehicle Specifications
2024 INTEGRATED CE S BUS (PB105)

September 09, 2022

<u>Code</u>	<u>Description</u>
	<u>Includes</u> : WARRANTY Four Years
48RRA	UPHOLSTERY, SEAT, STITCHING Single
	<u>Includes</u> : WARRANTY Two Years
48RTV	SEAT, TRACK, LT, 30", 4 LEG (2)
48RUJ	SEAT, TRACK, LT, 39", 4 LEG (4)
48RUT	SEAT, TRACK, RT, 30", 4 LEG (2)
48RVA	SEAT, TRACK, RT, 39", 4 LEG (2)
48SBG	UPHOLSTERY, PASS SEATS, TYPE Vinyl, 42 Ounce
48SDJ	SEAT, PASS, LT, 39", 2 LEG (02)
	<u>Notes</u> : BTI Seating System Base Seat. Retrofittable, Contact IC Bus Application Engineering for more information.
48SKB	SEAT, PASS, RT, 39", 2 LEG (02)
	<u>Notes</u> : BTI Seating System Base Seat. Retrofittable, Contact IC Bus Application Engineering for more information.
48TZK	SEAT, DRIVER {National Premium} Air Suspension with Suspension Skirt, Triple Chamber Adjustable Air Lumbar, Adjustable Cushion and Back Bolsters, 6 Position Front Cushion Adjuster, 3 Position Rear Cushion Adjuster, 6 to 23 Degree Back Recline
	<u>Includes</u> : SEAT BELT, DRIVER Adjustable D-Loop Seat Belt, Single Locking Retractor
48USV	SEAT BACK, PASSENGER High Back
48UYC	HEATER, REAR WALL, RT SIDE 80,000 BTU
48UZN	ROOF HATCH, FRONT {Specialty Hybrid Adv H1975-025-191-0F} Emergency Exit with Outside Release, Alarm, English Decals
48VKV	SEAT BELT, DUAL Non-Retractable, Maroon/Brown, 04 Seats
48VPL	SEAT BELT, TRIPLE Non-Retractable, Maroon/Blue/Brown, 10 Sets
48VVR	STEP TREADS {Koroseal} Pebble White Nosing Only, with Non-Metal Backing, used with Formed Treaded Steps
48XXH	SEAT, CHILD, LT, 39", 2 LEG {BTI Seating System} (01) High Back, with Child Restraint System and Non-Retractable Maroon/Blue/Brown Lap Belts 7.5" on the Buckle Side
	<u>Notes</u> : BTI Seating System -Integrated Child Restraint. Retrofittable, Contact IC Bus Application Engineering for more information.
48XXT	SEAT, CHILD, RT, 39", 2 LEG {BTI Seating System} (01) High Back, with Child Restraint System and Non-Retractable Maroon/Blue/Brown Lap Belts 7.5" on the Buckle Side
	<u>Notes</u> : BTI Seating System -Integrated Child Restraint. Retrofittable, Contact IC Bus Application Engineering for more information.
49002	BODY PLAN, APPROVED VARIATION Number 002
49AHV	LIGHT, STROBE, STOP SIGN, FRT In Lieu Of Flashing Lights Furnished with Stop Sign, Speciality

Vehicle Specifications
2024 INTEGRATED CE S BUS (PB105)

September 09, 2022

<u>Code</u>	<u>Description</u>
49AMD	SWITCH, DRIVER PANEL, TYPE Rocker
49AMJ	ALARM, BACKING {Ecco #575} 107 dB
49AMT	CIRCUIT, PROTECTION Breakers, Manual Reset in Lieu of Fuses
	<u>Includes</u> : ACCESS PANEL for Body and Chassis Fuses/Circuit Breakers Located on Body Exterior; Below Driver Window
49AMY	SWITCH, REAR DOOR BUZZER for Emergency Door
49ANH	SWITCH, MAGNETIC, DISCONNECT Master, Ignition Operated, All Body Circuits
49ANU	SOURCE, POWER 12 VDC, Mounted In Dash
49ATK	LIGHT, INDIC, LIFT DOOR Green; Flashing, Located in Driver Area
49ATV	LIGHT, INDIC, WARNING LIGHTS Red and Amber
	<u>Includes</u> : LIGHTS, WARNING Indicator Located in Instrument Cluster
49AUM	SWITCH, MASTER FLASHER Omit Master Flasher Switch, 8-Lamp System
49AWU	SPEAKERS AND WIRING (6) Flush Mounted in Light Bar
49BCL	FLASHER SYSTEM (8) Warning Lights, 8-Lamp System, Electronic Relay Flasher, Sequential Operation, Red Lights Activate after Amber Lights, with Road Speed Parameters
49BCR	LIGHT, EXTERIOR, CHECK Automatically Activates Lights for Pre Trip Inspection
49BEW	MIRROR, REAR VIEW, EXTERIOR {Mirror Lite Super Nickels} Black, Motorized Head, Heated
49BMA	STOP ARM, FRONT {Specialty 2980} Air, 18" Octagon, Double Sided, 1/2" White Border, Hi Intensity Grade, Strobing LED Lights
49BTL	ANTENNA REI # 210073, Flexible Rubber Antenna with Swivel Base and 160" Cable
49BUT	VISOR, INTERIOR, LEFT FRONT 6" x 30", Transparent, For Left Windshield, with Finger Hold Adjustment Knob
49BVD	SWITCH, BATTERY Shut-Off, 300A Weather Resistant, In Battery Compartment
49BEV	MIRROR, CROSS VIEW, EXTERIOR (2) {Mirror Lite High Definition Busboy} Black
49BWL	LIFT, WHEELCHAIR {Braun Model NL919FIB} Gen-2, Power Pack Mounted Forward of Lift, 800-lb Capacity
49BYL	LIGHTS, DOME {Sound Off/OptiLuxx} (05) LED, Rectangular Recessed Type, Mounted in Light Bar
49BYT	LIGHTS, STOP (2) {Sound Off/OptiLuxx} and Tail; 7" Round LED, Red
49BYZ	LIGHTS, DIRECTIONAL, REAR (2) {Sound Off/OptiLuxx} LED, 7" Round Amber
49BZA	LIGHT, LIFT DOOR {Sound Off/OptiLuxx} 4" Oval 3 White LED, Flush Mounted, Exterior, 2 Below Door in Skirt and 1 Half Way up Left Side of Lift Door Opening
49BZC	LIGHT, LIFT DOOR, INTERIOR {Sound Off/OptiLuxx} Above Lift Door, Rectangular LED, with Door Operated Switch (Functionality May Be Included in Existing Dome Light)
49BZG	LIGHTS, BACK UP (2) {Sound Off/OptiLuxx} LED, 7" Round Clear
49CKT	FUEL FILLER PIPE Low Profile Neck Cap and Vent Hosing, for Use with Right Side Fill for Between the Rail Fuel Tanks, for Above the Floor Fuel Fill, for 25 GPM Fill Rate Only
49CLM	RADIO, ENTERTAINMENT AM/FM/USB Input/Auxiliary Input, Includes Antenna and Cable, with Public Address System

Vehicle Specifications
2024 INTEGRATED CE S BUS (PB105)

September 09, 2022

Code	Description
49DBR	HOOD, WARNING LAMP (4) Black, 8-Lamp System, One Hood Above Two Lights
49EAW	LIGHTS, MARKER, SIDE, INTERMED {Sound Off/OptiLuxx} LED, Amber, Rectangular, Armored, Intermediate, Centered, Required for Units 30 Foot or Longer
49EGC	MIRROR, INSIDE 6" x 30", Clear Safety Glass, Metal Back, Round Corners
49ENR	VISOR, INTERIOR, DRIVER LEFT 10" X 30" for Driver's Window
49ESC	LIGHTS, DOME, DRIVER {Sound Off/OptiLuxx} (1) LED, Rectangular, Mounted in Light Bar in Ceiling, with Separate Switch
49EUB	KIT, FIRST AID Metal; 24 Unit, Spec State
49GBG	KIT, BODY FLUID Arizona, Mounted on the Bulkhead
49GBV	WINDSHIELD WIPERS (2) Cowl Mounted <u>Includes</u> : WINDSHIELD WIPERS CONTROL Single Motor, Overlapping Wipe Pattern
49GDC	PADDING COMPART ABOVE DRIVER Window; Safety Equipment Compartment, with Cutout for Dome Light
49GDS	COMPARTMENT ABOVE DRIVER Left of the Driver <u>Includes</u> : COMPARTMENT ABOVE DRIVER Compartment Size: 39" x 10" x 10" : HINGES Piano Type
49GEH	SAFETY TRIANGLES Warning Reflectors, Mounted on Drivers Barrier 9.5" Above Floor
49GGE	FIRE EXTINGUISHER, DRIVER AREA 5 lb 2A-40BC Minimum, with Flexible Hose and Metal Nozzle
49GKZ	FUEL FILLER DOOR with Non-Locking Latch
49GLA	REFLECTORS, SIDE, INTERMEDIATE (2) 3" Amber, 1 Each Side, Mounted with Screws, Below The Third Rub Rail From the Top
49GLG	REFLECTORS, SIDE, REAR (2) 3", Red, Mounted with Screws
49GLM	REFLECTORS, SIDE, FRONT (2) 3", Amber; 1 Aft Drivers Window Left, 1 Aft Entrance Door Right, Mounted with Screws
49GLP	REFLECTORS, REAR (2) 3", Red, Mounted with Screws
49GMM	INTERLOCK, LIFT for FMVSS Wheel Chair Interlock Requirements; Key Off, Lift Door Must be Open before Lift can be Activated, w/ Key in "On or Accessory" Position, Park Brake Must be Applied, Transmission in Neutral, Lift Door Must be Open Before Lift Can be Activated, w/ Automatic or Precision Transmissions
49GUB	CUTTER, SEAT BELT {TIE TECH Safecut} for Cutting Seat Belts
49GUK	FENDERS, RUBBER, REAR (2)
49GUM	INSPECTION PLATE Fuel Sending Unit 8" x 8" Steel
49GVA	MUD FLAPS, FRONT WHEELS (2) Anti-Sail and Anti-Spray
49GVH	MUD FLAPS, REAR WHEELS (2) Brackets Only
49GWW	WINDSHIELD WASHER Kit; 6 Quart Capacity, Bottle <u>Includes</u> : WINDSHIELD WASHER ELECTRICAL CONNECTIONS Sealed and Locking Type
49HAJ	STORAGE COMPARTMENT, BELTS (3) for Q-Straint Wheelchair Belts, Mounted to Wall
49HGC	TRACK, FLOOR LENGTHS 251"-300", with Full Shoulder Track

Vehicle Specifications
2024 INTEGRATED CE S BUS (PB105)

September 09, 2022

<u>Code</u>	<u>Description</u>
49HHB	TIE DOWN, TRACK (03) Retractable
49JAD	DEF FILLER DOOR with Locking Latch
49JBG	TRACK, TYPE (BRAND) {OMNI L Track}
49JBS	LIGHTS, CLUSTER {Sound Off/OptiLuxx} Oval, 4 Internal LEDs per Light; Amber Front and Red Rear
49JBU	LIGHT, ENTRY DOOR {Sound Off/OptiLuxx} LED; 4" Oval; Light Mounted in Skirt Behind Entrance Door, Wired To Step Light
49JBX	LIGHT, STEP {Sound Off/OptiLuxx} 4" Round LED, White, Wired to Ignition, Operated by Entrance Door
49JBY	LIGHTS, MARKER, FRONT & REAR (4) {Sound Off/OptiLuxx} LED, Armored, Slim-Line, (2) Amber Front and (2) Red Rear
49MJX	TIE DOWN, TRACK TYPE {QRT Q-8107-A1-L2} Retractable, with Track Fittings on Shoulder Belt
49MZV	LATCH, COMPARTMENT Locking, for Overhead Storage Compartment
49NGB	LIGHT, COMPARTMENT, ENGINE {Sound Off/OptiLuxx} LED 4" Oval; Activated with Parking Lights, with On/Off Switch, Includes Limit Switch that Allows Light to come on When Hood is Opened
49NGG	LIGHTS, TAIL, LICENSE PLATE (2) {Sound Off/OptiLuxx} 4" Round LED, Red, Includes Stop & Light Window, Includes Mounting Gasket
49NGJ	LIGHTS, WARNING (8) {Sound Off/OptiLuxx} (4) 7" Round Red Strobing LED and (4) 7" Round Amber Strobing LED, 2 Front, 2 Rear Each Color
49PSW	SWITCH, NOISE SUPPRESSION Actuator Legend States, "NOISE SUPP ", for Separate Solenoid, with Yellow Switch in Panel, with AC Memory Retention
49PSY	LIGHTS, DIRECTIONAL, SIDE {Sound Off/OptiLuxx} (2) Slim-Line LED Armored, Amber, (1) Each Side First Section Aft Entrance Door
49UAC	STATE OF OPERATION Arizona
50PEK	BODY PLAN, SPECIAL NEEDS Conventional; 26' 8" Body Length, +9 Front & Rear Section, 44 Passenger, 218" WB, DX7635A000
7752525421	(2) TIRE, FRONT 255/70R22.5 Load Range H HSR2 SA (CONTINENTAL), 565 rev/mile, 75 MPH, All-Position
7752525421	(4) TIRE, REAR 255/70R22.5 Load Range H HSR2 SA (CONTINENTAL), 565 rev/mile, 75 MPH, All-Position
OBD001	BRAKE SYSTEM, HYDRAULIC Not requested
OBD002	MISCELLANEOUS stock unit - sq not needed. only sent to clear tops

Services Section:

40126	WARRANTY Standard for CE, RE, BE School Bus Models, Effective with Vehicles Built March 1, 2017 or Later, CTS-3304H
40PLB	SRV CONTRACT, EXT VEH COVERAGE {Navistar} To 36-Month/50,000 Miles (80,000 km), Covers 100% Parts and Labor; Includes Body; Excludes Extending Warranty for Engine, Transmission, Perforation or Corrosion of Cab/Cowl Structure and Paint
40RAT	SERVICES, TOWING {Navistar} Service Call to 60-Month/Unlimited Mileage to the Nearest IC Bus Dealer for Navistar Warrantable Failure as Contract Defined; Includes Engine Failure if Supplier Declines Tow Coverage & ESC Supplied thru Navistar; \$1100 (USA) Maximum Benefit per Incident
49GVN	WARRANTY 5-Year, Limited

Body/Allied Equipment
Code
Goods Purchased

Description

Vehicle Specifications
2024 INTEGRATED CE S BUS (PB105)

September 09, 2022

Code
Code

Description
Description

Turning Radius Summary
2024 INTEGRATED CE S BUS (PB105)

September 09, 2022

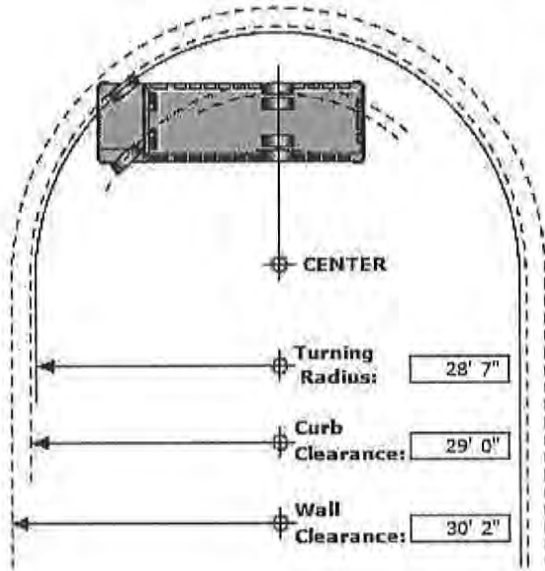

Series: INGB
 Model: PB105
 Description: INTEGRATED CE S BUS
 Model Year: 2024

Calculation Factors

Wheelbase: 217
 Front Axle: 0002AEM
 Description: AXLE, FRONT NON-DRIVING, {Dana Spicer D-800F} I-Beam Type, 8,000-lb Capacity
 Front Wheel: 0027DUW
 Description: WHEELS, FRONT, {Accuride 51408} DISC; 22.5x8.25 Rims, Powder Coat Steel, 2-Hand Hole, 10-Stud, 285.75mm BC, Hub-Piloted, Flanged Nut, with Steel Hubs
 Front Tire: 07752525421
 Description: TIRES, 255/70R22.5 Load Range H HSR2 SA (CONTINENTAL), 565 rev/mile, 75 MPH, All-Position
 Steering Gear: 0005PRG
 Description: STEERING GEAR, {TRW (Ross) TAS40} Power

Turning Radius Statistics

General Information

Inside Turn Angle: 50 Degrees
 Radial Overhang: 19

Axle Information

KingPin Inclination: 9 Degrees
 KingPin Center: 71

Turning Radius - Curb View

C - Curb Contact Length: 14.55
 CI - Curb Clearance Increment: 5.30
 CR - Curb Clearance Radius: 29'0"
 CH - Curb Height: 6"
 TR - Turning Radius: 28'7"
 TW - Tire Width: 10.00

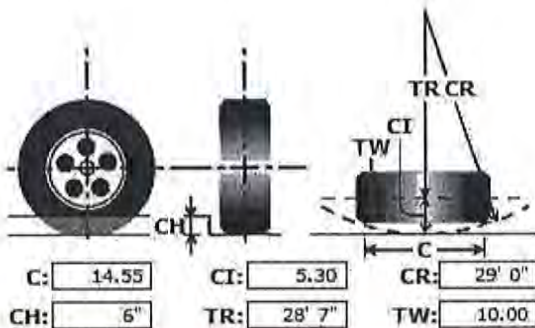

* All Measurements are in inches, unless otherwise specified.

This information is based on engineering information available at this time. Actual figures may vary. Navistar, Inc. cannot accept liability for consequences due to this variance.

Date: 3/10/23
 Quote Valid Until:
 Prepared By: TOM HARTMAN



Name:
 Organization: EQUALIS GROUP
 Address:
 City, State ZIP:
 Phone:

YEAR:	2024
MAKE:	COLLINS
MODEL:	GM GAS BUS
CAPACITY:	30
STOCK #'S:	RWCGM-2

INCLUDES 3 CAMERA SYSTEM AND DVR INCLUDES AC SYSTEM EV FREEBLOW		\$ 148,000.00
TRADE BUS #:		Trade Total: \$ -
		Pre Tax Sub Total: \$ 148,000.00
		Sales Tax (): \$ -
Local Delivery Charge: 0		\$ -
		\$ -
TOTAL PRICE:		\$ 148,000.00

RWC6M6-2 Collins Gas 30 passensea



SRO-9347	^ 70k Adjustable Ac Louvers	1
110-DH416-15	CORE DRW 76" STD FLR 4SEC+16	1
115-1416-00-20	TRIM BODY 4SEC+16	1
12323D6612W320	CU/23/D139/6.6G/12300/W/ACTC	1
200-112170-21	AC 70K ACT CHEVY 66G EV20/ROOF	1
210-11-000-20	BATTERY OEM LOCATION CHEV GAS	1
220-03-19	BATTERY DELETE CHEVY 2ND	1
220-42-20	HIGH IDLE CHEVY OBD	1
230-200-15	BUMPER 10" GALV EXH UNDER/SD	1
233-201-16	BRACE BUMPER DE/H 400/416/500	1
236-1110-16	CHAS FUEL PREP C GAS SL/SH/DH	1
238-1-416-0-12	CHASSIS MODEL PREP CHEV L/H416	1
250-211-12	DOOR ENTRANCE SH/DH TEMP	1
260-3-13	DOOR ENTRANCE CONTROL ELEC REL	1
265-212-22	DOOR REAR EGRESS ALUM RH HINGE	1
270-01-12	DOOR REAR HINGE 1PC STAINLESS	1
280-10-13	DOOR REAR LATCH 1PT	1
294-02-12	* ELEC FRAMEWORK CHEV SCHOOL BUS	1
300-51-12	BACK-UP ALARM	1
305-00000-20	CHILD ALERT NONE	1
310-2120-00-20	BACKUP CAMERA W/7" RVW MON	1
320-400-113-12	EXHST CHEV 400/416 LEFT GAS	1
330-103-12	* ENDCAPS DH W/WARNING LIGHT	1
332-213-22	EXT PANELS REAR DH STL W/DR	1
334-416-21-12	EXT PANELS ROOF DRW 416 ALUM	1
336-416-302-14	EXT PANELS SIDE DH 416 STEEL	1
338-1416-22-14	SKIRT DH 416 STEEL NO CONDENSER	1
339-112-20-14	EXT SKIRT NOBOX SL/H/DH4XX STL	1
345-11-12	DRIVER ENTRANCE STEP CHEV ALUM	1
350-416-21-1-12	FLOOR COVER BLK DRW CENTER 416	1
355-02-11-12	STEP TREAD DH/E RIB BACKED BLK	1
360-416-21-12	FLOOR SUBFLOOR DH/E416 1/2 PLY	1
400-21-12	HEATER 60K FLR MOUNT CHEV GAS	1
420-416-10-14	INT PANELS LOWER EMBOSS H416	1
422-031-15	INT PANELS REAR DH/DE AC	1
430-416-100-13	INT PNLS UPPR DRW 416 SMTH ALM	1
440-01-12	GRABRAIL LH ENTR 42IN BARR MNT	1
440-22-22	VANDAL LCK RR DOOR CHEV	1
440-50-13	DRIVER CUPHOLDER CONSOLE	1
445-01-20	APPLICATION INTERIOR PERMASAFE	1
450-01-12	STOP/TAIL/TURN 4IN FLUSH LED	1
460-02-12	STOP/TAIL 7IN RED LED	1

470-01-12	CLEARANCE LIGHTS LED	1
472-01-12	LIGHTS DOME BODY IGN+SWITCH	1
474-01-12	LIGHTS DOME DRIVER OEM DASH/DR	1
480-05-12	TURN SIGNAL REAR 7IN AMBER LED	1
490-01-12	LIGHTS REVERSE 4IN FLUSH LED	1
494-01-12	LIGHTS STEPWELL IGN+DOOR	1
510-00-12	* WARNING LAMPS NONE	1
520-00-12	* WARNING SYSTEM NONE	1
540-05-12	TURN SIGNAL MIDBODY AMBER LED	1
565-12-1110-12	MIRROR EXT GM DRW REM HT BL	1
580-03-202-12	PADDING PKG DH GRY FB	1
600-12-001-14	PAINT BODY EXT CHEV DH/DE WHIT	1
640-06-12	SPEAKERS 2 INTERNAL OEM RADIO	2
650-41620001-12	RUBRAIL FLR LVL DH/DE416 WHT	1
652-41620001-12	RUBRAIL SEAT LVL DH/DE416 WHT	1
654-00000000-12	• RUBRAIL NONE AT WINDOW LEVEL	1
656-00000000-12	• RUBRAIL NONE AT SKIRT LEVEL	1
660-12-12	TRIANGLE WARNING REFLECTORS 3	1
660-21-12	FIRE EXT 2.5LB 1A 10BC FRT MNT	1
670-061-12	BODY FLUID KIT #208-061 AZ	1
680-010-12	First Aid Kit #205-010	1
690-3-01-36-202	BARRIER LH 39D GRAY FB	1
691-2-12	• BARRIER SPACING LH 2PAX FMVSS	1
700-3-01-36-202	BARRIER RH 39 GRAY FB	1
701-0-12	• BARRIER SPACING RH NONE	1
710-2-10-35-122	SEAT LH SB39 GRAY	4
711-28-12	• SEAT SPACING LH 28IN HIP/KNEE	3
720-2-10-35-122	SEAT RH SB 39 GRAY	4
721-27-12	• SEAT SPACING RH 27IN HIP/KNEE	4
730-01-14	INSTALL SEAT TO FLOOR BOLT/NUT	7
740-211-12	SEAT BELT 60IN BLACK FREEDMAN	8
740-212-12	SEAT BELT 60IN GRAY FREEDMAN	8
780-100-12	SIGNAGE ID COLLINS	1
800-01-12	DECALS STANDARD REAR DOOR	1
810-422-12	EQUIPMENT CAGE 36IN LH DH/DE	1
840-01-12	• STOPARM NONE	1
860-04-12	STATIC ROOF VENT NONCLOSEABLE	1
870-01-001-12	HATCH TRAN MODEL 1975 1IN W	1
925-01-12	WINDOW TRANSITION CHEV TEMP	1
950-113-12	WNDWS REAR BODY TEMP AS3	1
960-13-12	WNDW REAR DOOR LOWER TEMP AS3	1
970-13-12	WNDW REAR DOOR UPPER TEMP AS3	1
980-213-12	WINDOW SASH H/E TEMP TINT	8
985-01-12	UNDERCOATING STANDARD	1
986-03-14	WARRANTY BODY 5-3-3 YR EXT LIM	1

Date: 3/10/23
Quote Valid Until:
Prepared By: TOM HARTMAN



Name:
Organization: EQUALIS GROUP
Address:
City, State ZIP:
Phone:

YEAR:	2024
MAKE:	COLLINS
MODEL:	GM GAS BUS
CAPACITY:	18 PLUS 1 WC
STOCK #'S:	RWCGM-3

		\$ 152,000.00
INCLUDES 3 CAMERA SYSTEM AND DVR INCLUDES AC SYSTEM EV FREEBLOW		
TRADE BUS #:		
	Trade Total:	\$ -
	Pre Tax Sub Total:	\$ 152,000.00
	Sales Tax ():	\$ -
Local Delivery Charge:	0	\$ -
		\$ -
TOTAL PRICE:		\$ 152,000.00