

PROPOSAL FORM 1: TECHNICAL PROPOSAL

1. OVERVIEW & QUALIFICATIONS	
1.1. Company Information	
1.1.1. Company Name:	NPS Public Furniture Corp DBA National Public Seating
1.1.2. Corporate Street Address:	149 Entin Road, Clifton, NJ, 07014
1.1.3. Website:	https://www.nationalpublicseating.com/
1.1.4. Formation. In what year was the company formed? For how long has your company been operating under its present business name? If your company has changed its business name, include the most recent prior business name and the year of the name change.	Operating under current since 2011. Originally established in 1997 as National Public Seating Corp.
1.1.5. Primary Point of Contact. Provide information about the Respondent representative/contact person authorized to answer questions regarding the proposal submitted by your company:	Contact Name: Uri Salzman
	Title: Senior Project Manager
	Phone: (800) 261-4112 x 154
	E-Mail Address: usalzman@nationalpublicseating.com
1.1.6. Authorized Representative. Print or type the name of the Respondent representative authorized to address contractual issues, including the authority to execute a contract on behalf of Respondent, and to whom legal notices regarding contract termination or breach, should be sent (if not the same individual as in 1.1.9., provide the following information on each such representative and specify their function).	Contact Name: Uri Salzman
	Title: Senior Project Manager
	Phone: (800) 261-4112 x 154
	E-Mail Address: usalzman@nationalpublicseating.com
1.2. Financial Strength & Legal Considerations	
1.2.1. Financial Strength. Demonstrate your financial strength and stability with meaningful data. This could include, but is not limited to, such items as financial statements, SEC filings, credit & bond ratings, letters of credit, and detailed refence letters. Note: If the information disclosed in your response is considered "Trade Secret" as defined in Ohio Revised Code, Respondents may mark the information as a "Trade Secret" and the response	See attached financial stability letter.

will be redacted from any future use of the RFP response.	
1.2.2. <i>Bankruptcy & Insolvency.</i> Describe any bankruptcy or insolvency for your organization (or its predecessors, if any) or any principal of the firm in the last three (3) years.	None.
1.2.3. <i>Litigation.</i> Describe any litigation in which your company has been involved in the last three (3) years and the status of that litigation.	None.
1.3. Industry Qualifications	
1.3.1. <i>Company Identification.</i> How is your organization best identified? Is it a manufacturer, distributor, dealer, reseller, or service provider?	We are a manufacturer.
1.3.2. <i>Manufacturer Authorization.</i> If your company is best described as a distributor, dealer, reseller, or similar entity please certify that your organization is authorized to sell the products and services at the price points disclosed in this proposal.	N/A
1.3.3. <i>Authorized Distributors, Agents, Dealers, or Resellers.</i> Describe the different channels in which this contract will be made available to Equalis Group Members. Your response should include, but is not limited to, whether your organization will serve as the single point of sale or if the contract will be made available through a network of distributors, agents, dealers, or resellers. NOTE: Respondents intending to authorize distributors, agents, dealers, or resellers must complete <u>Proposal Form 7 - Dealer, Distributor and Reseller Authorization Form.</u>	National Public Seating products are sold exclusively through our global dealer network. Equalis Group Members will place orders directly with our authorized dealers.
1.3.4. <i>Network Relationship.</i> If your company is best described as a manufacturer or service provider, please describe how your dealer network operates to sell and deliver the Products & Services proposed in this RFP. If applicable, is your network independent or company owned?	Dealers are carefully vetted and receive ongoing training from NPS Relationship Managers. Once a dealer account is established, NPS Account Managers work closely with dealers to provide quotes, product recommendations and lead times.

<p>1.3.5. Industry Experience. How long has your company provided the products and services outlined in your proposal? What percentage of your company's revenue in each of the last three (3) full calendar years was generated from these products and services?</p>	<p>NPS has been manufacturing institutional grade furniture since 1997. As we are the manufacturer, 100% of our revenue is generated from these products.</p>
<p>1.3.6. Geographic Reach. Describe your company's <u>current</u> service area in the United States and which areas you intend to offer services under a resulting contract if awarded.</p>	<p>Our dealer network spans all 50 United States (and other countries). We intend offer products and services to all states under a resulting contract.</p>
<p>1.3.7. Certifications and Licenses. Provide a detailed explanation outlining the licenses and certifications that are i) required to be held, and ii) actually held by your organization (including third parties and subcontractors that you use). Has your company maintained these certifications on an ongoing basis? If not, when and why did your company lose any referenced certifications?</p> <p>NOTE: Provide copies of any of the certificates or licenses included in your response in Proposal Form 5 - Certifications and Licenses.</p>	<p>National Public Seating requires dealers to hold resale certificates in the states which they operate. Additionally, NPS and its subcontractors comply with all licensing/certification requirements under any cooperative purchasing agreements that we hold.</p>
<p>1.4. Public Sector Experience</p>	
<p>1.4.1. Public Sector Cooperative Contracts. Provide a list of the public sector cooperative contracts (e.g., state term contracts, public sector cooperatives, etc.) you currently hold or are authorized to sell through (if contracts are held with a manufacturer) and the annual revenue through those contracts in each of the last three (3) calendar year.</p> <p>NOTE: Please exclude information and data associated with Federal or GSA contracts.</p>	<p>[REDACTED]</p>
<p>1.4.2. Education Success. What is the i) total dollar amount, and ii) percentage of your company's total annual revenue generated by sales to educational institutions (i.e., K-12 schools & school districts and high education)?</p>	<p>[REDACTED]</p>
<p>1.4.3. Government Success. What is the i) total dollar amount, and ii) percentage of your</p>	<p>[REDACTED]</p>

<p>company's total annual revenue generated by sales to local governments (i.e., municipalities, counties, special districts, and state agencies)?</p>	
<p>1.4.4. Customer References. Provide references of at least five (5) local government or educational institution customers for which your company has provided products and services similar in nature and scope to those defined in this RFP in the last three (3) years. Each reference should include:</p> <ul style="list-style-type: none"> a. Customer contact person and their title, telephone number, and email address; b. A brief description of the products and services provided by your company; c. Customer relationship starting and ending dates; and, d. Notes or other pertinent information relating to the customer and/or the products and services your company provided. 	<p>See attachment labeled "References".</p>

2. Products & Services

2.1. Products & Services

2.1.1. Product & Services Description(s). Provide a detailed description of the products and services you are offering as a part of your proposal.

Your response may include, but is not limited to, information related to product or market focus, differentiators, manufacturing capabilities & advantages, warranty information, turnkey capabilities, installation or set-up, training services, maintenance services, or any other piece of information that would help understand the breadth and depth of your products and service offering.

IMPORTANT. This description along with the products and services included in the **Attachment**

NPS focuses on offering complete, rounded out product lines including: **Chairs** (Folding, Stacking, Banquet, Café, Mobile Tablet Arm), **Folding Benches**, **Tables** (Plastic Folding, Wood Folding, Training/Seminar, Café, Science Lab, Heavy-Duty, Makerspace) **Mobile Cafeteria Tables** (Fixed Benches, Fixed Stools, Tables without Fixed Seating, Flip-Top EasyFold Tables, Booth Seating), **Stools** (Lab, Task, Art, Café), **Portable Stages & Risers**, **Music Room** (Student Chairs, Music Stands, Conductor's Sets), **Mobile Science Cabinets**, **Workstations** (Pneumatic Lift Desks, Desk/Lectern Combo's, Science Lab Workstations), **Portable Room Dividers**, **Dollies** (Folding Chairs Dollies, Stack Chairs Dollies, Folding Tables Dollies, Stage Dollies, Music Stand Dollies), **Lecterns**, **A/V Presentation Carts**, **Tablet/Laptop Charging Stations**, **Portable PA System**, **Installation of NPS furniture**. Please find our full 2023 catalog and 2024 new product brochures in the attachments.

<p>B – Cost Proposal will be utilized to define the overall products and services available under a resulting contract.</p>	
<p>2.1.2. Value-Add or Additional Offering. Please include any additional products and services not included in the scope of the solicitation that you think will enhance and add value to this contract’s participating agencies.</p>	<p>NPS Design Services: our in-house design team enables dealers to present 2D room layouts and 3D renders to help members visualize a space and make informed decisions. NPS employs an in-house technician to field service cafeteria tables should the need arise. We maintain a large stock of replacement parts and parts under \$25 ship free of charge. NPS publishes its product catalog in 2020 and CET, enabling dealers and designers to specify and visualize NPS products for members.</p>
<p>2.1.3. Open Market Products. Provide a detailed description of your ability to accommodate requests for Open Market Products. Open Market Products is a category of products that cannot be found in your standard catalog offering or non-inventoried products.</p>	<p>We will do our best to accommodate requests for Open Market Products. If we determine that we are able to produce a "sourced" or "custom" product, it will be quoted per request and may be subject to minimum order quantities.</p>
<p>2.1.4. Warranty. Provide a copy of the manufacturer’s warranty. If required, please attach the warranty as an attachment, as instructed in this document. Describe notable features and/or characteristics of the warranty that a public sector customer would find interesting or appealing. Pricing related to the any extended warranty options must be included in <u>Attachment B – Cost Proposal.</u></p>	<p>National Public Seating provides a warranty to the original user covering all manufacturing defects in material and workmanship from the date of purchase for a period of ten years (exceptions noted below). In the event of a defect, NPS will, at its discretion, either repair or replace the defective product. Exceptions to 10-year warranty: Mobile cafeteria tables - 15 years, Natural wood surfaces (butcherblock) - 1 year, Basics by NPS branded products - 1 year. Please find our full warranty attached.</p>

3. Business Operations

3.1. Logistics

3.1.1. Store & Showroom Locations; Distribution & Shipping Capabilities.

Describe how supplier proposes to distribute the products & services in Respondent’s defined geographic reach.

Your response may include, but is not limited to, information related to the number of store or showroom locations, distribution facilities, supply chain partners, fill rates, on-time delivery rates, and your ability to accommodate expedited orders.

NPS operates three Lightning Ship (2-day lead time) in New Jersey, Tennessee and California. These facilities are strategically positioned to optimize storage, manufacturing and distribution processes with advanced logistics systems and excellent connectivity to transportation networks. Our Clifton, NJ headquarters also features the NPS showroom and our domestic manufacturing facility. Lead times categories are: 2-Day Lightning Ship (stock items), 7-Day Quick Ship (made to order items in popular finishes), 8-Week Standard (general made to order items) and 16 Weeks for fully custom solutions.

3.2. Customer Service

<p>3.2.1. Customer Service Department. Describe your company's customer service department & operations. Your description may include, but is not limited to, hours of operation, number and location of service centers, parts outlets, number of customer service representatives. Clarify if the service centers are owned by your company or if they are a network of subcontractors.</p>	<p>National Public Seating maintains a highly trained in-house Customer Care team consisting of 3 regional care representatives, a field technician and a team manager. The team has a strong expertise in our products and servicing customers. We pride ourselves on our quick response time (1-hour target response time company-wide). The Customer Care team leverages Freshdesk software to ensure timely response and ticket management for all issues. Our online service portal is also available for warranty, freight damage and product shortage issues 24/7. The team is available from 9am-5pm eastern Mon-Thursday, 9am-2:30pm Fri, and can be reached at (800) 261-4112 or by emailing customer-care@nationalpublicseating.com.</p>
<p>3.3. Customer Set Up; Order & Invoice Processing; Payment</p>	
<p>3.3.1. Proposal Development, Order, and Invoice Process. Describe your company's proposal development, order, and invoice process.</p>	<p>Members request an Equalis quote directly from an authorized dealer. If an entity contacts NPS directly, NPS will connect them with an authorized dealer to facilitate a quote. Dealer will provide the member with a quote specifying the contract number and highlighting any 'open market' items. The member places a PO directly with the dealer, referencing the contract number on their PO. Dealer places a PO with NPS referencing the contract number and attaching the member PO for review to ensure pricing compliance. NPS order managers review the PO and enter it in our ERP system with the contract number in a dedicated field. Member PO's are reviewed for pricing accuracy by the NPS Contract Manager. Dealers will invoice and receive payments from members directly. Once an order ships, a record of the order is exported to our CRM system for sales reporting and performance review.</p>
<p>3.3.2. Financing. Does your company offer any financing options or programs? If yes, describe the financing options available to Members.</p>	<p>As members would place orders through and be directly invoiced by our authorized dealers, each dealer will be the point of contact for members seeking financing options.</p>
<p>3.4. Sustainability, Reclamation, and Recycling Initiatives</p>	
<p>3.4.1. Sustainable Company Initiatives. Describe the ways in which your company is addressing the issue of sustainability.</p>	<p>Please see attachment labeled "Environmental Statement".</p>
<p>4. PRICING</p>	
<p>4.1. Cost Proposal</p>	
<p>4.1.1. Pricing Model. Provide a description of your pricing model or methodology identifying how the model works for the</p>	<p>NPS will be submitting a tiered discount off MSRP structure for our entire catalog as well as a not-to-exceed hourly rate for installation (to cover any prevailing wage scenarios).</p>

<p>products and services included in your proposal.</p>	
<p>4.1.2. Auditable. Describe how the proposed pricing model is able to be audited by public sector agencies or CCOG to assure compliance with pricing in the Master Agreement.</p>	<p>Pricing is a catalog discount off MSRP for products, making it easily auditable for CCOG and public sector agencies. Installation is to be quoted to members as a not-to-exceed hourly rate, making it easily auditable as well. NPS requires copies of all member PO's from our dealers for reporting purposes as well as for in-house audits of each order by our Contracts Manager to assure compliance.</p>
<p>4.1.3. Cost Proposal Value. Which of the following statements best describes the pricing offered included in Respondent's cost proposal.</p>	<p>The prices offered in your Cost Proposal are:</p> <p><input type="checkbox"/> lower than what you offer other group purchasing organizations, cooperative purchasing organizations, or state purchasing departments.</p> <p><input type="checkbox"/> equal to what you offer other group purchasing organizations, cooperative purchasing organizations, or state purchasing departments.</p> <p><input type="checkbox"/> higher than what you offer other group purchasing organizations, cooperative purchasing organizations, or state purchasing departments.</p> <p><input checked="" type="checkbox"/> not applicable. Please explain below.</p> <p>Due to the different delivery requirements for each contract (delivered, delivered and installed etc.), there is no standard discount that applies to all proposals. Pricing here is similar or better to what is offered on proposals with similar scope and requirements.</p>
<p>4.1.4. Additional Savings. Describe any quantity or volume discounts or rebate programs included in your Cost Proposal.</p>	<p>NPS is offering volume discounts based on the total list price for each order.</p>
<p>4.1.5. Cost of Shipping. Is the cost of shipping included in the pricing submitted with your response? If no, describe how cost associated with freight, shipping, and delivery are calculated.</p>	<p>No. Freight quotes are calculated for each order either via our ERP's freight quote tool which returns real-time rates within 1 minute for each request, or via spot quotes from our logistics partners if needed (typical response time within 1 hour).</p>
<p>4.1.6. Pricing Open Market or Sourced Goods. If relevant, propose a method for the pricing of Open Market Items. For example, you may supply such items "at cost" or "at cost plus a percentage" or you supply a quote for each such request.</p> <p>NOTE: For a definition of Open Market Items, please refer to Part One, Section 5.4 – Other Pricing Scenarios.</p>	<p>If we determine that we are able to produce a "sourced" or "custom" product, it will be quoted per request and may be subject to minimum order quantities.</p>
<p>4.1.7. Total Cost of Acquisition. Identify any components included in the total cost of acquisition that are NOT included in the pricing submitted with your response. This</p>	<p>N/A</p>

<p>cost includes all additional charges that are not directly identified as freight or shipping charges. For example, list costs for items like installation, set up, mandatory training, or initial inspection. Identify any parties that impose such costs and their relationship to the Respondent.</p>	
--	--

5. GO-TO-MARKET STRATEGY

5.1. Respondent Organizational Structure & Staffing of Relationship

<p>5.1.1. Key Contacts. Provide contact information and resumes for the person(s) who will be responsible for the following areas;</p> <ol style="list-style-type: none"> 1. Executive Contact 2. Contract Manager 3. Sales Leader 4. Reporting Contact 5. Marketing Contact. <p>***Indicate who the primary contact will be if it is not the Sales Leader.</p>	<p>See attachment labeled “Key Contacts”.</p>
---	---

<p>5.1.2. Sales Organization. Provide a description of your sales organization, including key staff members, the size of the organization, in-house vs. third-party sales resources, geographic territories, vertical market segmentation, etc.</p>	<p>NPS employs an in-house sales team consisting of the following: VP of Sales, Director of Business Development, Regional Sales Director, Director of Corporate Sales, Senior Project Manager/Contracts Manager, Product Data Specialist, 4 Regional Relationship Managers (responsible for qualifying and opening new dealer accounts, maintaining existing dealer relationships, dealer strategies, training dealers on products and services), and 4 Regional Account Managers (responsible for day-to-day operations including quoting, closing orders, project registration and working with the contract manager to advise dealers on contracts). We also employ an in-house design team to assist dealers with space planning and design.</p>
--	---

5.2. Contract Implementation Strategy & Expectations

<p>5.2.1. Contract Expectation. What are your company’s expectations in the event of a contract award?</p>	<p>As we sell exclusively through our dealer network, we rely heavily on dealer input to determine which contracts to pursue. In addition to the success we’ve seen with our current Equalis contract, new dealers have stressed to us the importance of the Equalis contract as a growth vehicle in their local markets. We expect that with our wide range of products offered, experienced dealer network, and a continued partnership with Equalis, we can significantly grow contract sales across the US.</p>
---	---

<p>5.2.2. Five (5) Year Sales Vision & Strategy. Describe your company’s vision and strategy to leverage a resulting contract</p>	<p>NPS will integrate the Equalis contract into our sales process by including it in dealer training presentations, creating a clear contract info sheet to familiarize dealers and our internal sales</p>
--	--

<p>with Equalis over the next five (5) years. Your response may include but is not limited to; the geographic or public sector vertical markets being targeted; your strategy for acquiring new business and retaining existing business; how the contract will be deployed with your sales team; how you will market the contract, including deployment of the contract on your company website; how you will market the contract, including deployment of the contract on your company website; and the time frames in which this will be completed.</p>	<p>team with pricing and terms, and leverage the contract to develop dealer relationships, especially with dealers who have stressed the importance of this contract in their respective regions. Upon award: the President of NPS send an email out to the sales team announcing/endorsing the contract as a leading national contract vehicle to promote to dealers. Within a week of award: create and distribute a co-branded email blast to authorized dealers announcing the award. Upload a contract info sheet to our website (add a link to the award page on the Equalis website once available). Within 1 month of award: create a co-branded brochure for our sales team and dealer network with details about the contract including pricing, benefits and ease of use. Brochure is to be incorporated into future dealer training sessions when discussing Equalis. Hold online or in-person training sessions with each authorized dealer including training on the new contract. Review of the purchasing process as it relates to authorized dealers to ensure accurate sales reporting. Ongoing marketing efforts throughout the term of the contract will include: encouraging dealers to publish case studies of successful projects sold through the contract. The NPS graphics team will create co-branded materials for dealers upon request to assist them in marketing the contract to end users.</p>
<p>5.2.3. Sales Objectives. What are your top line sales objectives in each of the five (5) years if awarded this contract?</p>	<p>Year 1: \$200k, Year 2: \$400k, Year 3: \$700k, Year 4: \$900k, Year 5: \$1.1M</p>
<p>6. ADMIN FEE & REPORTING</p>	
<p>6.1. Administration Fee & Reporting</p>	

<p>6.1.1. Administrative Fee. Equalis Group only generates revenue when the Winning Supplier generates revenue based on contract utilization by current and future Members.</p> <p>The administrative fee is normally calculated as a percentage of the total Spend for agencies accessing product and services through the Master Agreement and is typically two percent (2%) to three percent (3%). In some categories, a flat fee or another fee structure may be acceptable.</p> <p>Please provide your organization's proposed Administrative Fee percentage or structure.</p> <p>NOTE: The proposed Administrative Fee language for this contract is based on the terms disclosed in the <u>Attachment A – Model Administration Agreement</u>.</p>	
<p>6.1.2. Sales & Administrative Fee Reporting. Equalis Group requires monthly reports detailing sales invoiced the prior month and associated Administrative Fees earned by the 15th of each month. Confirm that your company will meet this reporting requirement. If not, explain why and propose an alternative time schedule for providing these reports to Equalis Group.</p>	<p>Confirmed.</p>
<p>6.1.3. Self-Audit. Describe any self-audit process or program that you plan to employ to verify compliance with your proposed contract with Equalis Group. This process includes ensuring that you sales organization provides and Members obtain the correct pricing, reports reflect all sales made under the Contract, and Winning Supplier remit the proper admin fee to Equalis.</p>	<p>In order to authorize a dealer to participate in a NPS held contract, dealers must provide the NPS Contract Manager with a dedicated POC for contract sales reporting. Additionally, dealers are required to reference the contract # on their own PO and supply NPS with a copy of the member PO. NPS order managers review each PO and enter them in our ERP system which has a dedicated Contract # field. Every contract order is then reviewed by the Contract Manager for pricing and compliance. The Contract Manager then documents shipped orders in the sales reporting template to ensure accurate reporting and admin fee remittance. Shipped orders are then exported to our CRM system for teamwide visibility and performance reviews.</p>

PROPOSAL FORM 3: DIVERSITY VENDOR CERTIFICATION PARTICIPATION

Diversity Vendor Certification Participation - It is the policy of some Members participating in Equalis Group to involve minority and women business enterprises (M/WBE), small and/or disadvantaged business enterprises, disable veterans business enterprises, historically utilized businesses (HUB) and other diversity recognized businesses in the purchase of goods and services. Respondents shall indicate below whether or not they hold certification in any of the classified areas and include proof of such certification with their response.

a. Minority Women Business Enterprise

Respondent certifies that this firm is an MWBE: Yes No

List certifying agency: [Click or tap here to enter text.](#)

b. Small Business Enterprise (SBE) or Disadvantaged Business Enterprise (“DBE”)

Respondent certifies that this firm is a SBE or DBE: Yes No

List certifying agency: [Click or tap here to enter text.](#)

c. Disabled Veterans Business Enterprise (DVBE)

Respondent certifies that this firm is an DVBE: Yes No

List certifying agency: [Click or tap here to enter text.](#)

d. Historically Underutilized Businesses (HUB)

Respondent certifies that this firm is an HUB: Yes No

List certifying agency: [Click or tap here to enter text.](#)

e. Historically Underutilized Business Zone Enterprise (HUBZone)

Respondent certifies that this firm is an HUBZone: Yes No

List certifying agency: [Click or tap here to enter text.](#)

f. Other

Respondent certifies that this firm is a recognized diversity certificate holder: Yes No

List certifying agency: [Click or tap here to enter text.](#)

PROPOSAL FORM 4: CERTIFICATIONS AND LICENSES

Provide a copy of all current licenses, registrations and certifications issued by federal, state and local agencies, and any other licenses, registrations or certifications from any other governmental entity with jurisdiction, allowing Respondent to provide the products and services included in their proposal which can include, but not limited to licenses, registrations or certifications. M/WBE, HUB, DVBE, small and disadvantaged business certifications and other diverse business certifications, as well as manufacturer certifications for sales and service must be included if applicable.

Please also list and include copies of any certificates you hold that would show value for your response and was not already included with the requested information above.

See attached CEIR and NJ Business Registration Certificate.

(The rest of this page is intentionally left blank)

STATE OF NEW JERSEY
BUSINESS REGISTRATION CERTIFICATE

DEPARTMENT OF TREASURY/
DIVISION OF REVENUE
PO BOX 252
TRENTON, N J 08646-0252

TAXPAYER NAME:

NPS PUBLIC FURNITURE CORP

TRADE NAME:

ADDRESS:

**149 ENTIN ROAD
CLIFTON NJ 07014**

SEQUENCE NUMBER:

1635914

EFFECTIVE DATE:

04/28/11

ISSUANCE DATE:

04/28/11



Director
New Jersey Division of Revenue

FORM-BRC

(04-08), D205846V

This Certificate is NOT assignable or transferable. It must be conspicuously displayed at above address.

PROPOSAL FORM 5: UNRESOLVED FINDINGS FOR RECOVERY

O.R.C. Chapter 9.24 prohibits CCOG from awarding a contract to any entity against whom the Auditor of State has issued a finding for recovery, if such finding for recovery is “unresolved” at the time of award. By submitting a proposal, a Respondent warrants that it is not now, and will not become, subject to an “unresolved” finding for recovery under **O.R.C. Chapter 9.24** prior to the award of any contract arising out of this RFP, without notifying CCOG of such finding. The Proposal Review Team will not evaluate a proposal from any Respondent whose name, or the name of any of the subcontractors proposed by the Respondent, appears on the website of the Auditor of the State of Ohio as having an “unresolved” finding for recovery.

Is your company the subject of any unresolved findings for recoveries?

- Yes
- No

PROPOSAL FORM 6: MANDATORY DISCLOSURES

1. *Mandatory Contract Performance Disclosure.*

Disclose whether your company's performance and/or the performance of any of the proposed subcontractor(s) under contracts for the provision of products and services that are the same or similar to those to be provided for the Program which is the subject of this RFP has resulted in any formal claims for breach of those contracts. For purposes of this disclosure, "**formal claims**" means any claims for breach that have been filed as a lawsuit in any court, submitted for arbitration (whether voluntary or involuntary, binding or not), or assigned to mediation. For any such claims disclosed, fully explain the details of those claims, including the allegations regarding all alleged breaches, any written or legal action resulting from those allegations, and the results of any litigation, arbitration, or mediation regarding those claims, including terms of any settlement. While disclosure of any formal claims will not automatically disqualify a Respondent from consideration, at the sole discretion of Equalis Group, such claims and a review of the background details may result in a rejection of a Respondent's proposal. Equalis Group will make this decision based on the Proposal Review Team's determination of the seriousness of the claims, the potential impact that the behavior that led to the claims could have on the Respondent's performance of the work, and the best interests of Members.

Provide statement here. N/A

2. *Mandatory Disclosure of Governmental Investigations.*

Indicate whether your company and/or any of the proposed subcontractor(s) has been the subject of any adverse regulatory or adverse administrative governmental action (federal, state, or local) with respect to your company's performance of services similar to those described in this RFP. If any such instances are disclosed, Respondents must fully explain, in detail, the nature of the governmental action, the allegations that led to the governmental action, and the results of the governmental action including any legal action that was taken against the Respondent by the governmental agency. While disclosure of any governmental action will not automatically disqualify a Respondent from consideration, such governmental action and a review of the background details may result in a rejection of the Respondent's proposal at Group's sole discretion. Equalis Group will make this decision based on the Proposal Review Team's determination of the seriousness of the claims, the potential impact that the behavior that led to the claims could have on the Respondent's performance of the work, and the best interests of Members.

Provide statement here. N/A

PROPOSAL FORM 7: DEALER, RESELLER, AND DISTRIBUTOR AUTHORIZATION

CCOG allows Suppliers to authorize dealers, distributors, and resellers to sell the products and services made available through, and consistent with the Terms and Conditions set forth in, the Master Agreement. If Supplier intends to authorize their dealers, distributors, or resellers access to the Master Agreement in the event of a contract award Supplier must provide a list, either in the form of a document or a weblink, to identify those organizations who are being authorized access to the Master Agreement.

Will the Supplier authorize dealers, distributors, resellers access to Master Agreement?

Yes

No

If yes, how will Supplier disclose which organization(s) will have access to the Master Agreement? This list can be updated from time to time upon CCOG's approval.

Respondent Response: NPS will provide a spreadsheet of authorized dealers including Name, Address, Primary Contact Person and Contact Info.

Authorized Dealer List for Equalis Group/CCOG

Name of Dealer	Street Address	City	State	ZIP	Contact	Phone	Email
Commonwealth School Equipment	21403 Hull Street Road	Moseley	VA	23120	David Hawkins	(804) 739-4575	david@cseva.net
ECS Solutions	6608 Ladyslipper Lane	Clifton	VA	20124	Katie Bricker	(703) 403-5345	katie@ecs-ed.com
Hertz Furniture	170 Williams Drive	Ramsey	NJ	07446	Mutty Leiser	(800) 526-4677	mleiser@hertzfurniture.com
Martin Public Seating	5085 Park Ave W	Seville	OH	44273	Darrin Heydinger	(330) 769-2723	d.heydinger@martinpublicseating.com
Meteor Education	690 NE 23rd Ave	Gainesville	FL	32609	Caroline Smith	(800) 699-7516	csmith@meteoreducation.com
School Specialty	W6316 Design Drive	Greenville	WI	54942	Leonard Adkins	(419) 589-1656	leonard.adkins@schoolspecialty.com

PROPOSAL FORM 8: MANDATORY SUPPLIER & PROPOSAL CERTIFICATIONS

CCOG may not enter into contracts with any suppliers who have been found to be ineligible for state contracts under specific federal or Ohio statutes or regulations. Companies responding to any CCOG RFP MUST certify that they are NOT ineligible by signing each of the statements below. **Failure to provide proper affirming signature on any of these statements will result in a Respondent's proposal being deemed nonresponsive to this RFP.**

I, Uri Salzman, hereby certify and affirm that NPS Public Furniture Corp DBA National Public Seating, has not been debarred, suspended, proposed for debarment, declared ineligible, or voluntarily excluded from participation in transactions by the United States Department of Labor, the United States Department of Health and Human Services, or any other federal department or agency as set forth in 29 CFR Part 98, or 45 CFR Part 76, or other applicable statutes.

AND

I, Uri Salzman, hereby certify and affirm that NPS Public Furniture Corp DBA National Public Seating, is in compliance with all federal, state, and local laws, rules, and regulations, including but not limited to the Occupational Safety and Health Act and the Ohio Bureau of Employment Services and the following:

- Not penalized or debarred from any public contracts or falsified certified payroll records or any other violation of the Fair Labor Standards Act in the last three (3) years;
- Not found to have violated any worker's compensation law within the last three (3) years;
- Not violated any employee discrimination law within the last three (3) years;
- Not have been found to have committed more than one (1) willful or repeated OSHA violation of a safety standard (*as opposed to a record keeping or administrative standard*) in the last three (3) years;
- Not have an Experience Modification Rating of greater than 1.5 (a penalty-rated employer) with respect to the Bureau of Workers' Compensation risk assessment rating; and
- Not have failed to file any required tax returns or failed to pay any required taxes to any governmental entity within the past three (3) years.

AND

I, , hereby certify and affirm that , is not on the list established by the Ohio Secretary of State, pursuant to **ORC Section 121.23**, which identifies persons and businesses with more than one unfair labor practice contempt of court finding against them.

AND

I, , hereby certify and affirm that either is not subject to a finding for recovery under **ORC Section 9.24**, or has taken appropriate remedial steps required under that statute to resolve any findings for recovery, or otherwise qualifies under that section to enter into contracts with CCOG.

I, , hereby affirm that this proposal accurately represents the capabilities and qualifications of , and I hereby affirm that the cost(s) proposed to CCOG for the performance of services and/or provision of goods covered in this proposal in response to this CCOG RFP is a firm fixed price structure as described in the Cost Proposal, inclusive of all incidental as well as primary costs. (*Failure to provide the proper affirming signature on this item may result in the disqualification of your proposal.*)

PROPOSAL FORM 10: DEBARMENT NOTICE

I, the Respondent, certify that my company has not been debarred, suspended or otherwise ineligible for participation in Federal Assistance programs under Executive Order 12549, "Debarment and Suspension", as described in the Federal Register and Rules and Regulations.

Respondents Name:	NPS Public Furniture Corp DBA National Public Seating
Mailing Address:	149 Entin Road, Clifton, NJ 07014
Signature	
Title of Signatory:	Senior Project Manager

PROPOSAL FORM 9: CLEAN AIR ACT & CLEAN WATER ACT

The Respondent is in compliance with all applicable standards, orders or regulations issued pursuant to the Clean Air Act of 1970, as Amended (42 U.S. C. 1857 (h), Section 508 of the Clean Water Act, as amended (33 U.S.C. 1368), Executive Order 117389 and Environmental Protection Agency Regulation, 40 CFR Part 15 as required under OMB Circular A-102, Attachment O, Paragraph 14 (1) regarding reporting violations to the grantor agency and to the United States Environment Protection Agency Assistant Administrator for the Enforcement.

Authorized signature:



Printed Name:

Uri Salzman

Company Name:

NPS Public Furniture Corp DBA National
Public Seating

Mailing Address:

149 Entin Road, Clifton, NJ 07014

Email Address:

usalzman@nationalpublicseating.com

Job Title:

Senior Project Manager

PROPOSAL FORM 13: BOYCOTT CERTIFICATION

Respondent must certify that during the term of any Agreement, it does not boycott Israel and will not boycott Israel. "Boycott" means refusing to deal with, terminating business activities with, or otherwise taking any action that is intended to penalize, inflict economic harm on, or limit commercial relations specifically with Israel, or with a person or entity doing business in Israel or in an Israeli-controlled territory, but does not include an action made for ordinary business purposes.

Does Respondent agree? US

(Initials of Authorized Representative)

PROPOSAL FORM 12: CONTRACTOR CERTIFICATION REQUIREMENTS

1. Contractor's Employment Eligibility

By entering the contract, Contractor warrants compliance with the Federal Immigration and Nationality Act (FINA), and all other federal and state immigration laws and regulations. The Contractor further warrants that it is in compliance with the various state statutes of the states it will operate this contract in.

Participating Government Entities including School Districts may request verification of compliance from any Contractor or subcontractor performing work under this Contract. These Entities reserve the right to confirm compliance in accordance with applicable laws.

Should the Participating Entities suspect or find that the Contractor or any of its subcontractors are not in compliance, they may pursue any and all remedies allowed by law, including, but not limited to: suspension of work, termination of the Contract for default, and suspension and/or debarment of the Contractor. All costs necessary to verify compliance are the responsibility of the Contractor.

The Respondent complies and maintains compliance with the appropriate statutes which requires compliance with federal immigration laws by State employers, State contractors and State subcontractors in accordance with the E-Verify Employee Eligibility Verification Program.

Contractor shall comply with governing board policy of the CCOG Participating entities in which work is being performed.

2. Fingerprint & Criminal Background Checks

If required to provide services on school district property at least five (5) times during a month, contractor shall submit a full set of fingerprints to the school district if requested of each person or employee who may provide such service. Alternately, the school district may fingerprint those persons or employees. An exception to this requirement may be made as authorized in Governing Board policy. The district shall conduct a fingerprint check in accordance with the appropriate state and federal laws of all contractors, subcontractors or vendors and their employees for which fingerprints are submitted to the district. Contractor, subcontractors, vendors and their employees shall not provide services on school district properties until authorized by the District.

The Respondent shall comply with fingerprinting requirements in accordance with appropriate statutes in the state in which the work is being performed unless otherwise exempted.

Contractor shall comply with governing board policy in the school district or Participating Entity in which work is being performed.

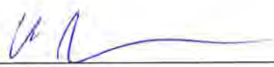
Signature: 
Date: 11/16/2023

PROPOSAL FORM 11: LOBBYING CERTIFICATIONS

Submission of this certification is a prerequisite for making or entering into this transaction and is imposed by **Section 1352, Title 31, U.S. Code**. This certification is a material representation of fact upon which reliance was placed when this transaction was made or entered into. Any person who fails to file the required certification shall be subject to civil penalty of not less than ten thousand dollars (\$10,000) and not more than one hundred thousand dollars (\$100,000) for each such failure.

The undersigned certifies, to the best of his/her knowledge and belief, on behalf of Respondent that:

1. No Federal appropriated funds have been paid or will be paid on behalf of the undersigned, to any person for influencing or attempting to influence an officer or employee of any agency, a Member of Congress, an officer or employee of Congress, or an employee of a Member of Congress in connection with the awarding of a Federal contract, the making of a Federal grant, the making of a Federal loan, the entering into a cooperative agreement, and the extension, continuation, renewal, amendment, or modification of a Federal contract, grant, loan, or cooperative agreement.
2. If any funds other than Federal appropriated funds have been or will be paid to any person for influencing or attempting to influence an officer or employee of any agency, a Member of Congress, an officer or employee of Congress, or an employee of a Member of Congress in connection with this Federal contract or cooperative agreement, the undersigned shall complete and submit Standard Form LLL, "Disclosure of Lobbying Activities," in accordance with its instructions.
3. The undersigned shall require that the language of this certification be included in the award documents for all covered sub-awards exceeding one hundred thousand dollars (\$100,000) in Federal funds at all appropriate tiers and that all sub-recipients shall certify and disclose accordingly.

Signature:



Date:

11/16/2023

PROPOSAL FORM 15: FEMA FUNDING REQUIREMENTS CERTIFICATION FORMS

Please answer the following question. If yes, complete this Proposal Form.

In the event of a contract award, does the Respondent intend to make their products and services available to public agencies utilizing FEMA funds or seeking reimbursement from FEMA?	<input checked="" type="checkbox"/>	Yes
	<input type="checkbox"/>	No

When a participating agency seeks to procure goods and services using funds under a federal grant or contract, specific federal laws, regulations, and requirements may apply in addition to those under state law. This includes, but is not limited to, the procurement standards of the Uniform Administrative Requirements, Cost Principles and Audit Requirements for Federal Awards, 2 CFR 200 (sometimes referred to as the "Uniform Guidance" or "EDGAR" requirements). Additionally, Appendix II to Part 200 authorizes FEMA to require or recommend additional provisions for contracts.

All bidders submitting proposals who desire to work with Members utilizing FEMA funds must complete this FEMA Recommended Contract Provisions Form regarding bidder's willingness and ability to comply with certain requirements which may be applicable to specific participating agency purchases using FEMA funds. This completed form will be made available to Members for their use while considering their purchasing options when using FEMA grant funds. Members may also require Supplier Partners to enter into ancillary agreements, in addition to the contract's general terms and conditions, to address the member's specific contractual needs, including contract requirements for a procurement using federal grants or contracts.

For each of the items below, Bidder should certify bidder's agreement and ability to comply, where applicable, by having respondents authorized representative complete and initial the applicable lines after each section and sign the acknowledgment at the end of this form. If a Bidder fails to complete any item in this form, CCOG will consider the respondent's response to be that they are unable or unwilling to comply. A negative response to any of the items may, if applicable, impact the ability of a participating agency to purchase from the Supplier Partner using federal funds.

16. Access to Records

For All Procurements

The Winning Supplier agrees to provide the participating agency, the pass-through entity (if applicable), the FEMA Administrator, the Comptroller General of the United States, or any of their authorized representatives access to any books, documents, papers, and records of the Contractor which are directly pertinent to this contract for the purposes of making audits, examinations, excerpts, and transcriptions.

The Winning Supplier agrees to permit any of the foregoing parties to reproduce by any means whatsoever or to copy excerpts and transcriptions as reasonably needed.

The Winning Supplier agrees to provide the FEMA Administrator or his authorized representatives access to construction or other work sites pertaining to the work being completed under the contract.

Does Respondent agree? US
(Initials of Authorized Representative)

For Contracts Entered into After August 1, 2017, Under a Major Disaster or Emergency Declaration

In compliance with section 1225 of the Disaster Recovery Reform Act of 2018, the participating agency, and the Winning Supplier acknowledge and agree that no language in this contract is intended to prohibit audits or internal reviews by the FEMA Administrator or the Comptroller General of the United States."

Does Respondent agree? US
(Initials of Authorized Representative)

17. Changes

FEMA recommends that all contracts include a changes clause that describes how, if at all, changes can be made by either party to alter the method, price, or schedule of the work without breaching the contract. The language of the clause may depend on the nature of the contract and the procured item(s) or service(s). The participating agency should also consult their servicing legal counsel to determine whether and how contract changes are permissible under applicable state, local, or tribal laws or regulations.

Does Respondent agree? US
(Initials of Authorized Representative)

18. Use of DHS Seal, Logo, and Flags

The Winning Supplier shall not use the DHS seal(s), logos, crests, or reproductions of flags or likenesses of DHS agency officials without specific FEMA pre-approval. The contractor shall include this provision in any subcontracts.

Does Respondent agree? US
(Initials of Authorized Representative)

19. Compliance with Federal Law, Regulations, And Executive Orders and Acknowledgement of Federal Funding

This is an acknowledgement that when FEMA financial assistance is used to fund all or a portion of the participating agency's contract with the Winning Supplier, the Winning Supplier will comply with all applicable federal law, regulations, executive orders, FEMA policies, procedures, and directives.

Does Respondent agree? US
(Initials of Authorized Representative)

20. No Obligation by Federal Government

The federal government is not a party to this or any contract resulting from this or future procurements with the participating agencies and is not subject to any obligations or liabilities to the non-federal entity, contractor, or any other party pertaining to any matter resulting from the contract.

Does Respondent agree? US
(Initials of Authorized Representative)

21. Program Fraud and False or Fraudulent Statements or Related Acts

The Winning Supplier acknowledges that 31 U.S.C. Chap. 38 (Administrative Remedies for False Claims and Statements) applies to the contractor's actions pertaining to this contract.

Does Respondent agree? US
(Initials of Authorized Representative)

22. Affirmative Socioeconomic Steps

If subcontracts are to be let, the Winning Supplier is required to take all necessary steps identified in 2 C.F.R. § 200.321(b)(1)-(5) to ensure that small and minority businesses, women’s business enterprises, and labor surplus area firms are used when possible.

Does Respondent agree? US
(Initials of Authorized Representative)

23. License and Delivery of Works Subject to Copyright and Data Rights

The Winning Supplier grants to the participating agency, a paid-up, royalty-free, nonexclusive, irrevocable, worldwide license in data first produced in the performance of this contract to reproduce, publish, or otherwise use, including prepare derivative works, distribute copies to the public, and perform publicly and display publicly such data. For data required by the contract but not first produced in the performance of this contract, the Winning Supplier will identify such data and grant to the participating agency or acquires on its behalf a license of the same scope as for data first produced in the performance of this contract. Data, as used herein, shall include any work subject to copyright under 17 U.S.C. § 102, for example, any written reports or literary works, software and/or source code, music, choreography, pictures or images, graphics, sculptures, videos, motion pictures or other audiovisual works, sound and/or video recordings, and architectural works. Upon or before the completion of this contract, the Winning Supplier will deliver to the participating agency data first produced in the performance of this contract and data required by the contract but not first produced in the performance of this contract in formats acceptable by the (insert name of the non-federal entity).

Does Respondent agree? US
(Initials of Authorized Representative)

By signature below, I certify that the information in this form is true, complete, and accurate and that I am authorized by my company to make this certification and all consents and agreements contained herein.

Authorized signature:  _____

Printed Name: Uri Salzman
Company Name: NPS Public Furniture Corp DBA National Public Seating
Mailing Address: 149 Entin Road, Clifton, NJ 07014
Job Title: Senior Project Manager

PROPOSAL FORM 14: FEDERAL FUNDS CERTIFICATION FORMS

When a participating agency seeks to procure goods and services using funds under a federal grant or contract, specific federal laws, regulations, and requirements may apply in addition to those under state law. This includes, but is not limited to, the procurement standards of the Uniform Administrative Requirements, Cost Principles and Audit Requirements for Federal Awards, 2 CFR 200 (sometimes referred to as the "Uniform Guidance" or "EDGAR" requirements).

All Respondents submitting proposals must complete this Federal Funds Certification Form regarding Respondent's willingness and ability to comply with certain requirements which may be applicable to specific participating agency purchases using federal grant funds. This completed form will be made available to Members for their use while considering their purchasing options when using federal grant funds. Members may also require Supplier Partners to enter into ancillary agreements, in addition to the contract's general terms and conditions, to address the member's specific contractual needs, including contract requirements for a procurement using federal grants or contracts.

For each of the items below, respondent should certify their agreement and ability to comply, where applicable, by having respondents authorized representative complete and initial the applicable lines after each section and sign the acknowledgment at the end of this form. If a Respondent fails to complete any item in this form, CCOG will consider the Respondent's response to be that they are unable or unwilling to comply. A negative response to any of the items may, if applicable, impact the ability of a participating agency to purchase from the Supplier Partner using federal funds.

1. *Supplier Partner Violation or Breach of Contract Terms*

Contracts for more than the simplified acquisition threshold currently set at one hundred fifty thousand dollars (\$150,000), which is the inflation adjusted amount determined by the Civilian Agency Acquisition Council and the Defense Acquisition Regulations Council (Councils) as authorized by 41 USC 1908, must address administrative, contractual, or legal remedies in instances where Supplier Partners violate or breach contract terms, and provide for such sanctions and penalties as appropriate.

Any contract award will be subject to Terms and Conditions of the Master Agreement, as well as any additional terms and conditions in any purchase order, participating agency ancillary contract, or Member construction contract agreed upon by Supplier Partner and the participating agency which must be consistent with and protect the participating agency at least to the same extent as the CCOG Terms and Conditions.

The remedies under the contract are in addition to any other remedies that may be available under law or in equity. By submitting a proposal, you agree to these Supplier Partner violation and breach of contract terms.

Does Respondent agree? US

(Initials of Authorized Representative)

2. *Termination for Cause or Convenience*

When a participating agency expends federal funds, the participating agency reserves the right to immediately terminate any agreement in excess of ten thousand dollars (\$10,000) resulting from this procurement process in the event of a breach or default of the agreement by Offeror in the event Offeror fails to: (1) meet schedules, deadlines, and/or delivery dates within the time specified in the procurement solicitation, contract, and/or a purchase order; (2) make any payments owed; or (3) otherwise perform in accordance with the contract and/or the procurement solicitation. Participating agency also reserves the right to terminate the contract immediately, with written notice to offeror, for convenience, if participating agency believes, in its sole discretion that it is in the best interest of participating agency to do so. Respondent

will be compensated for work performed and accepted and goods accepted by participating agency as of the termination date if the contract is terminated for convenience of participating agency. Any award under this procurement process is not exclusive and participating agency reserves the right to purchase goods and services from other offerors when it is in participating agency's best interest.

Does Respondent agree? US

(Initials of Authorized Representative)

3. Equal Employment Opportunity

Except as otherwise provided under 41 CFR Part 60, all participating agency purchases or contracts that meet the definition of "federally assisted construction contract" in 41 CFR Part 60-1.3 shall be deemed to include the equal opportunity clause provided under 41 CFR 60-1.4(b), in accordance with Executive Order 11246, "Equal Employment Opportunity" (30 FR 12319, 12935, 3 CFR Part, 1964-1965 Comp., p. 339), as amended by Executive Order 11375, "Amending Executive Order 11246 Relating to Equal Employment Opportunity," and implementing regulations at 41 CFR Part 60, "Office of Federal Contract Compliance Programs, Equal Employment Opportunity, Department of Labor."

The equal opportunity clause provided under 41 CFR 60-1.4(b) is hereby incorporated by reference. Supplier Partner agrees that such provision applies to any participating agency purchase or contract that meets the definition of "federally assisted construction contract" in 41 CFR Part 60-1.3 and Supplier Partner agrees that it shall comply with such provision.

Does Respondent agree? US

(Initials of Authorized Representative)

4. Davis-Bacon Act

When required by Federal program legislation, Supplier Partner agrees that, for all participating agency prime construction contracts/purchases in excess of two thousand dollars (\$2,000), Supplier Partner shall comply with the Davis-Bacon Act (40 USC 3141-3144, and 3146-3148) as supplemented by Department of Labor regulations (29 CFR Part 5, "Labor Standards Provisions Applicable to Contracts Covering Federally Financed and Assisted Construction"). In accordance with the statute, Supplier Partner is required to pay wages to laborers and mechanics at a rate not less than the prevailing wages specified in a wage determinate made by the Secretary of Labor. In addition, Supplier Partner shall pay wages not less than once a week.

Current prevailing wage determinations issued by the Department of Labor are available at www.wdol.gov. Supplier Partner agrees that, for any purchase to which this requirement applies, the award of the purchase to the Supplier Partner is conditioned upon Supplier Partner's acceptance of the wage determination.

Supplier Partner further agrees that it shall also comply with the Copeland "Anti-Kickback" Act (40 USC 3145), as supplemented by Department of Labor regulations (29 CFR Part 3, "Contractors and Subcontractors on Public Building or Public Work Financed in Whole or in Part by Loans or Grants from the United States". The Act provides that each Supplier Partner or subrecipient must be prohibited from inducing, by any means, any person employed in the construction, completion, or repair of public work, to give up any part of the compensation to which he or she is otherwise entitled.

Does Respondent agree? US

(Initials of Authorized Representative)

5. *Contract Work Hours and Safety Standards Act*

Where applicable, for all participating agency contracts or purchases in excess of one hundred thousand dollars (\$100,000) that involve the employment of mechanics or laborers, Supplier Partner agrees to comply with 40 USC 3702 and 3704, as supplemented by Department of Labor regulations (29 CFR Part 5). Under 40 USC 3702 of the Act, Supplier Partner is required to compute the wages of every mechanic and laborer on the basis of a standard work week of forty (40) hours. Work in excess of the standard work week is permissible provided that the worker is compensated at a rate of not less than one and a half times the basic rate of pay for all hours worked in excess of forty (40) hours in the work week. The requirements of 40 USC 3704 are applicable to construction work and provide that no laborer or mechanic must be required to work in surroundings or under working conditions which are unsanitary, hazardous or dangerous. These requirements do not apply to the purchases of supplies or materials or articles ordinarily available on the open market, or contracts for transportation or transmission of intelligence.

Does Respondent agree? US

(Initials of Authorized Representative)

6. *Right to Inventions Made Under a Contract or Agreement*

If the participating agency's Federal award meets the definition of "funding agreement" under 37 CFR 401.2(a) and the recipient or subrecipient wishes to enter into a contract with a small business firm or nonprofit organization regarding the substitution of parties, assignment or performance or experimental, developmental, or research work under that "funding agreement," the recipient or subrecipient must comply with the requirements of 37 CFR Part 401, "Rights to Inventions Made by Nonprofit Organizations and Small Business Firms Under Government Grants, Contracts and Cooperative Agreements," and any implementing regulations issued by the awarding agency.

Supplier Partner agrees to comply with the above requirements when applicable.

Does Respondent agree? US

(Initials of Authorized Representative)

7. *Clean Air Act and Federal Water Pollution Control Act*

Clean Air Act (42 USC 7401-7671q.) and the Federal Water Pollution Control Act (33 USC 1251-1387), as amended – Contracts and subgrants of amounts in excess of one hundred fifty thousand dollars (\$150,000) must contain a provision that requires the non-Federal award to agree to comply with all applicable standards, orders, or regulations issued pursuant to the Clean Air Act (42 USC 7401-7671q.) and the Federal Water Pollution Control Act, as amended (33 USC 1251-1387). Violations must be reported to the Federal awarding agency and the Regional Office of the Environmental Protection Agency (EPA).

When required, Supplier Partner agrees to comply with all applicable standards, orders, or regulations issued pursuant to the Clean Air Act and the Federal Water Pollution Control Act.

Does Respondent agree? US

(Initials of Authorized Representative)

8. *Debarment and Suspension*

Debarment and Suspension (Executive Orders 12549 and 12689) – A contract award (see 2 CFR 180.220) must not be made to parties listed on the government-wide exclusions in the System for Award Management (SAM), in accordance

with the OMB guidelines at 2 CFR 180 that implement Executive Orders 12549 (3 CFR Part 1966 Comp. p. 189) and 12689 (3CFR Part 1989 Comp. p. 235), "Debarment and Suspension." SAM Exclusions contains the names of parties debarred, suspended, or otherwise excluded by agencies, as well as parties declared ineligible under statutory or regulatory authority other than Executive Order 12549.

Supplier Partner certifies that Supplier Partner is not currently listed on the government-wide exclusions in SAM, is not debarred, suspended, or otherwise excluded by agencies or declared ineligible under statutory or regulatory authority other than Executive Order 12549. Supplier Partner further agrees to immediately notify the Cooperative and all Members with pending purchases or seeking to purchase from Supplier Partner if Supplier Partner is later listed on the government-wide exclusions in SAM, or is debarred, suspended, or otherwise excluded by agencies or declared ineligible under statutory or regulatory authority other than Executive Order 12549.

Does Respondent agree? US

(Initials of Authorized Representative)

9. *Byrd Anti-Lobbying Amendment*

Byrd Anti-Lobbying Amendment (31 USC 1352) – Supplier Partners that apply or bid for an award exceeding one hundred thousand dollars (\$100,000) must file the required certification. Each tier certifies to the tier above that it will not and has not used Federal appropriated funds to pay any person or organization for influencing or attempting to influence an officer or employee of any agency, a member of Congress, officer or employee of Congress, or an employee of a member of Congress in connection with obtaining any Federal contract, grant or any other award covered by 31 USC 1352. Each tier must also disclose any lobbying with non-Federal funds that takes place in connection with obtaining any Federal award. Such disclosures are forwarded from tier to tier up to the non-Federal award. As applicable, Supplier Partner agrees to file all certifications and disclosures required by, and otherwise comply with, the Byrd Anti-Lobbying Amendment (31 USC 1352).

Does Respondent agree? US

(Initials of Authorized Representative)

10. *Procurement of Recovered Materials*

For participating agency purchases utilizing Federal funds, Supplier Partner agrees to comply with Section 6002 of the Solid Waste Disposal Act, as amended by the Resource Conservation and Recovery Act where applicable and provide such information and certifications as a participating agency maybe required to confirm estimates and otherwise comply. The requirements of Section 6002 includes procuring only items designated in guidelines of the Environmental Protection Agency (EPA) at 40 CFR Part 247 that contain the highest percentage of recovered materials practicable, consistent with maintaining a satisfactory level of competition, where the purchase price of the item exceeds ten thousand dollars (\$10,000) or the value of the quantity acquired during the preceding fiscal year exceeded ten thousand dollars (\$10,000); procuring solid waste management services in a manner that maximizes energy and resource recovery, and establishing an affirmative procurement program for procurement of recovered materials identified in the EPA guidelines.

Does Respondent agree? US

(Initials of Authorized Representative)

11. *Profit as a Separate Element of Price*

For purchases using federal funds in excess of one hundred fifty thousand dollars (\$150,000), a participating agency may be required to negotiate profit as a separate element of the price. See, 2 CFR 200.324(b). When required by a participating

agency, Supplier Partner agrees to provide information and negotiate with the participating agency regarding profit as a separate element of the price for a particular purchase. However, Supplier Partner agrees that the total price, including profit, charged by Supplier Partner to the participating agency shall not exceed the awarded pricing, including any applicable discount, under Supplier Partner's Group Purchasing Agreement.

Does Respondent agree? US

(Initials of Authorized Representative)

12. Prohibition on Certain Telecommunications and Video Surveillance Services or Equipment

Vendor agrees that recipients and subrecipients are prohibited from obligating or expending loan or grant funds to procure or obtain, extend or renew a contract to procure or obtain, or enter into a contract (or extend or renew a contract) to procure or obtain equipment, services, or systems that uses covered telecommunications equipment or services as a substantial or essential component of any system, or as critical technology as part of any system from companies described in Public Law 115-232, section 889. Telecommunications or video surveillance equipment or services produced or provided by an entity that the Secretary of Defense, in consultation with the Director of the National Intelligence or the Director of the Federal Bureau of Investigation, reasonably believes to be an entity owned or controlled by, or otherwise connected to, the government of a covered foreign country are also prohibited.

Does Respondent agree? US

(Initials of Authorized Representative)

13. Domestic preferences for procurements

For participating agency purchases utilizing Federal funds, Respondent agrees to provide proof, where applicable, that the materials, including but not limited to, iron, aluminum, steel, cement, and other manufactured products are produced in the United States.

"Produced in the United States" means, for iron and steel products, that all manufacturing processes, from the initial melting stage through the application of coatings, occurred in the United States.

"Manufactured products" means items and construction materials composed in whole or in part of non-ferrous metals such as aluminum; plastics and polymer-based products such as polyvinyl chloride pipe; aggregates such as concrete; glass, including optical fiber; and lumber.

Does Respondent agree? US

(Initials of Authorized Representative)

14. General Compliance and Cooperation with Members

In addition to the foregoing specific requirements, Vendor agrees, in accepting any purchase order from a Member, it shall make a good faith effort to work with Members to provide such information and to satisfy such requirements as may apply to a particular participating agency purchase or purchases including, but not limited to, applicable recordkeeping and record retention requirements.

Does Respondent agree? US

(Initials of Authorized Representative)

15. Applicability to Subcontractors

Offeror agrees that all contracts it awards pursuant to the Contract shall be bound by the foregoing terms and conditions.

Does Respondent agree? US

(Initials of Authorized Representative)

By signature below, I certify that the information in this form is true, complete, and accurate and that I am authorized by my company to make this certification and all consents and agreements contained herein.

Authorized signature: 

Printed Name: Uri Salzman
Company Name: NPS Public Furniture DBA National Public Seating
Mailing Address: 149 Entin Road, Clifton, NJ 07014
Job Title: Senior Project Manager

PROPOSAL FORM 16: ARIZONA CONTRACTOR REQUIREMENTS

Please answer the following question. If yes, please complete this Proposal Form.

Does the awarded supplier intend to make their products and services available to public agencies in the State of Arizona?	<input checked="" type="checkbox"/> Yes <input type="checkbox"/> No
--	--

In the event the Awarded Supplier desires to pursue public sector opportunities in the State of Arizona, it is important to understand the requirements for working with those public agencies. The documentation and information contained in this proposal form are intended to provide the Respondent with documentation that could be relevant to the providing products & services to public agencies in the State of Arizona. It is the responsibility of the public agency to ensure they are in compliance with local requirements.

AZ Compliance with Federal and State Requirements

Contractor agrees when working on any federally assisted projects with more than \$2,000.00 in labor costs, to comply with all federal and state requirements, as well as Equal Opportunity Employment requirements and all other federal and state laws, statutes, etc. Contractor agrees to post wage rates at the work site and submit a copy of their payroll to the member for their files. Contractor must retain records for three years to allow the federal grantor agency access to these records, upon demand. Contractor also agrees to comply with the Arizona Executive Order 75-5, as amended by Executive Order 99-4.

When working on contracts funded with Federal Grant monies, contractor additionally agrees to comply with the administrative requirements for grants, and cooperative agreements to state, local and federally recognized Indian Tribal Governments.

AZ compliance with workforce requirements

Pursuant to ARS 41-4401, Contractor and subcontractor(s) warrant their compliance with all federal and state immigration laws and regulations that relate to their employees, and compliance with ARS 23-214 subsection A, which states, "... every employer, after hiring an employee, shall verify the employment eligibility of the employee through the E-Verify program"

CCOG reserves the right to cancel or suspend the use of any contract for violations of immigration laws and regulations. CCOG and its members reserve the right to inspect the papers of any contractor or subcontract employee who works under this contract to ensure compliance with the warranty above.

AZ Contractor Employee Work Eligibility

By entering into this contract, contractor agrees and warrants compliance with A.R.S. 41-4401, A.R.S. 23-214, the Federal Immigration and Nationality Act (FINA), and all other Federal immigration laws and regulations. CCOG and/or CCOG members may request verification of compliance from any contractor or sub-contractor performing work under this contract. CCOG and CCOG members reserve the right to confirm compliance. In the event that CCOG or CCOG members suspect or find that any contractor or subcontractor is not in compliance, CCOG may pursue any and all remedies allowed by law, including but not limited to suspension of work, termination of contract, suspension and/or debarment of the contractor. All cost associated with any legal action will be the responsibility of the contractor.

AZ Non-Compliance

All federally assisted contracts to members that exceed \$10,000.00 may be terminated by the federal grantee for noncompliance by contractor. In projects that are not federally funded, Respondent must agree to meet any federal, state or local requirements as necessary. In addition, if compliance with the federal regulations increases the contract costs beyond the agreed upon costs in this solicitation, the additional costs may only apply to the portion of the work paid by the federal grantee.

Registered Sex Offender Restrictions (Arizona)

For work to be performed at an Arizona school, contractor agrees that no employee or employee of a subcontractor who has been adjudicated to be a registered sex offender will perform work at any time when students are present, or reasonably expected to be present. Contractor agrees that a violation of this condition shall be considered a material breach and may result in the cancellation of the purchase order at the CCOG member’s discretion. Contractor must identify any additional costs associated with compliance to this term. If no costs are specified, compliance with this term will be provided at no additional charge.

Offshore Performance of Work Prohibited

Due to security and identity protection concerns, direct services under this contract shall be performed within the borders of the United States.

Terrorism Country Divestments: In accordance with A.R.S. 35-392, CCOG and CCOG members are prohibited from purchasing from a company that is in violation of the Export Administration Act. By entering into the contract, contractor warrants compliance with the Export Administration Act.

The undersigned hereby accepts and agrees to comply with all statutory compliance and notice requirements listed in this document.

Does Respondent agree? US
(Initials of Authorized Representative)

Date: 11/26/2023

PROPOSAL FORM 17: NEW JERSEY REQUIREMENTS

Please answer the following question. If yes, please complete this Proposal Form.

Does the awarded supplier intend to make their products and services available to public agencies in the State of New Jersey?	<input checked="" type="checkbox"/> Yes <input type="checkbox"/> No
---	--

In the event the Awarded Supplier desires to pursue public sector opportunities in the State of New Jersey, it is important to understand the requirements for working with those public agencies. The documentation and information contained in this proposal form are intended to provide the Respondent with documentation that could be relevant to the providing products & services to public agencies in the State of New Jersey. It is the responsibility of the public agency to ensure they are in compliance with local requirements.

New Jersey vendors are also required to comply with the following New Jersey statutes when applicable:

- All anti-discrimination laws, including those contained in N.J.S.A. 10:2-1 through N.J.S.A. 10:2-14, N.J.S.A. 10:5-1, and N.J.S.A. 10:5-31 through 10:5-38.
- Compliance with Prevailing Wage Act, N.J.S.A. 34:11-56.26, for all contracts within the contemplation of the Act.
- Compliance with Public Works Contractor Registration Act, N.J.S.A. 34:11-56.26
- Bid and Performance Security, as required by the applicable municipal or state statutes.

A. Ownership Disclosure Form (N.J.S. 52:25-24.2)

Pursuant to the requirements of P.L. 1999, Chapter 440 effective April 17, 2000 (Local Public Contracts Law), the Respondent shall complete the form attached to these specifications listing the persons owning 10 percent (10%) or more of the firm presenting the proposal.

Company Name: NPS Public Furniture Corp DBA National Public Seating
 Street: 149 Entin Road
 City, State, Zip Code: Clifton, NJ 07014

Complete as appropriate:

I, Click or tap here to enter text, certify that I am the sole owner of Click or tap here to enter text, that there are no partners and the business is not incorporated, and the provisions of N.J.S. 52:25-24.2 do not apply.

OR:

I, Click or tap here to enter text, a partner in Click or tap here to enter text, do hereby certify that the following is a list of all individual partners who own a 10% or greater interest therein. I further certify that if one (1) or more of the partners is itself a corporation or partnership, there is also set forth the names and addresses of the stockholders holding 10% or more of that corporation's stock or the individual partners owning 10% or greater interest in that partnership.

OR:

I, Elliot Levy, an authorized representative of NPS Public Furniture Corp DBA National Public Seating, a corporation, do hereby certify that the following is a list of the names and addresses of all stockholders in the corporation who own 10% or more of its stock of any class. I further certify that if one (1) or more of such stockholders is itself a corporation or partnership, that there is also set forth the names and addresses of the stockholders holding 10% or more of the corporation's stock or the individual partners owning a 10% or greater interest in that partnership.

(Note: If there are no partners or stockholders owning 10% or more interest, indicate none.)

Name	Address	Interest
------	---------	----------



I further certify that the statements and information contained herein, are complete and correct to the best of my knowledge and belief.

Signature:

A handwritten signature in black ink, consisting of a large, stylized loop followed by a horizontal line that tapers to the right.

Date:

11/16/2023

B. Non-Collusion Affidavit

Respondent Name: NPS Public Furniture Corp DBA National Public Seating

Street Address: 149 Entin Road

City, State Zip: Clifton, NJ 07014

State of New Jersey

County of Passaic

I, Uri Salzman of the city of Thiells, in the County of Rockland, State of New York of full age, being duly sworn according to law on my oath depose and say that:

I am the Senior Project Manager of the firm of NPS Public Furniture Corp DBA National Public Seating the Respondent making the Proposal for the goods, services or public work specified under the Harrison Township Board of Education attached proposal, and that I executed the said proposal with full authority to do so; that said Respondent has not directly or indirectly entered into any agreement, participated in any collusion, or otherwise taken any action in restraint of free, competitive bidding in connection with the above proposal, and that all statements contained in said bid proposal and in this affidavit are true and correct, and made with full knowledge that the Harrison Township Board of Education relies upon the truth of the statements contained in said bid proposal and in the statements contained in this affidavit in awarding the contract for the said goods, services or public work.

I further warrant that no person or selling agency has been employed or retained to solicit or secure such contract upon an agreement or understanding for a commission, percentage, brokerage or contingent fee, except bona fide employees or bona fide established commercial or selling agencies maintained by

Authorized signature: 
Job Title: Senior Project Manager

Subscribed and sworn before me

this 16 day of November, 2023



Notary Public of New Jersey
My commission expires 07/01, 2024

SEAL



C. Affirmative Action Affidavit (P.L. 1975, C.127)

Company Name: NPS Public Furniture Corp DBA National Public Seating
Street Address: 149 Entin Road
City, State, Zip Code: Clifton, NJ 07014

Bid Proposal Certification:

Indicate below your compliance with New Jersey Affirmative Action regulations. Your proposal will be accepted even if you are not in compliance at this time. No contract and/or purchase order may be issued, however, until all Affirmative Action requirements are met.

Required Affirmative Action Evidence:

Procurement, Professional & Service Contracts (Exhibit A)

Suppliers must submit with proposal:

1. A photo copy of their Federal Letter of Affirmative Action Plan Approval
OR
2. A photo copy of their Certificate of Employee Information Report
OR
3. A complete Affirmative Action Employee Information Report (AA302)

Public Work – Over \$50,000 Total Project Cost:

No approved Federal or New Jersey Affirmative Action Plan. We will complete Report Form AA201-A upon receipt from the Harrison Township Board of Education

Approved Federal or New Jersey Plan – certificate enclosed

I further certify that the statements and information contained herein, are complete and correct to the best of my knowledge and belief.

Authorized Signature: 
Title of Signatory: Senior Project Manager
Date: 11/16/2023

P.L. 1995, c. 127 (N.J.A.C. 17:27)

MANDATORY AFFIRMATIVE ACTION LANGUAGE

PROCUREMENT, PROFESSIONAL AND SERVICE CONTRACTS

During the performance of this contract, the contractor agrees as follows:

The contractor or subcontractor, where applicable, will not discriminate against any employee or applicant for employment because of age, race, creed, color, national origin, ancestry, marital status, sex, affectional or sexual orientation. The contractor will take affirmative action to ensure that such applicants are recruited and employed, and that employees are treated during employment, without regard to their age, race, creed, color, national origin, ancestry, marital status, sex, affectional or sexual orientation. Such

action shall include, but not be limited to the following: employment, upgrading, demotion, or transfer; recruitment or recruitment advertising; layoff or termination; rates of pay or other forms of compensation; and selection for training, including apprenticeship. The contractor agrees to post in conspicuous places, available to employees and applicants for employment, notices to be provided by the Public Agency Compliance Officer setting forth provisions of this non-discrimination clause.

The contractor or subcontractor, where applicable will, in all solicitations or advertisement for employees placed by or on behalf of the contractor, state that all qualified applicants will receive consideration for employment without regard to age, race, creed, color, national origin, ancestry, marital status, sex, affectional or sexual orientation.

The contractor or subcontractor, where applicable, will send to each labor union or representative of workers with which it has a collective bargaining agreement or other contract or understanding, a notice, to be provided by the agency contracting officer advising the labor union or workers' representative of the contractor's commitments under this act and shall post copies of the notice in conspicuous places available to employees and applicants for employment.

The contractor or subcontractor, where applicable, agrees to comply with any regulations promulgated by the Treasurer pursuant to P.L. 1975, c. 127, as amended and supplemented from time to time and the Americans with Disabilities Act.

The contractor or subcontractor agrees to attempt in good faith to employ minority and female workers trade consistent with the applicable county employment goal prescribed by N.J.A.C. 17:27-5.2 promulgated by the Treasurer pursuant to P.L. 1975, C.127, as amended and supplemented from time to time or in accordance with a binding determination of the applicable county employment goals determined by the Affirmative

Action Office pursuant to N.J.A.C. 17:27-5.2 promulgated by the Treasurer pursuant to P.L. 1975, C.127, as amended and supplemented from time to time.

The contractor or subcontractor agrees to inform in writing appropriate recruitment agencies in the area, including employment agencies, placement bureaus, colleges, universities, labor unions, that it does not discriminate on the basis of age, creed, color, national origin, ancestry, marital status, sex, affectional or sexual orientation, and that it will discontinue the use of any recruitment agency which engages in direct or indirect discriminatory practices.

The contractor or subcontractor agrees to revise any of it testing procedures, if necessary, to assure that all personnel testing conforms with the principles of job-related testing, as established by the statutes and court decisions of the state of New Jersey and as established by applicable Federal law and applicable Federal court decisions.

The contractor or subcontractor agrees to review all procedures relating to transfer, upgrading, downgrading and lay-off to ensure that all such actions are taken without regard to age, creed, color, national origin, ancestry, marital status, sex, affectional or sexual orientation, and conform with the applicable employment goals, consistent with the statutes and court decisions of the State of New Jersey, and applicable Federal law and applicable Federal court decisions.

The contractor and its subcontractors shall furnish such reports or other documents to the Affirmative Action Office as may be requested by the office from time to time in order to carry out the purposes of these regulations, and public agencies shall furnish such information as may be requested by the Affirmative Action Office for conducting a compliance investigation pursuant to Subchapter 10 of the Administrative Code (NJAC 17:27).



Signature of Procurement Agent

D. C. 271 Political Contribution Disclosure Form

PUBLIC AGENCY INSTRUCTIONS

This page provides guidance to public agencies entering into contracts with business entities that are required to file Political Contribution Disclosure forms with the agency. **It is not intended to be provided to contractors.** What follows are instructions on the use of form local units can provide to contractors that are required to disclose political contributions pursuant to N.J.S.A. 19:44A-20.26 (P.L. 2005, c. 271, s.2). Additional information is available in Local Finance Notice 2006-1 (https://www.nj.gov/dca/divisions/dlgs/resources/lfns_2006.html).

1. The disclosure is required for all contracts in excess of \$17,500 that are **not awarded** pursuant to a “fair and open” process (N.J.S.A. 19:44A-20.7).
2. Due to the potential length of some contractor submissions, the public agency should consider allowing data to be submitted in electronic form (i.e., spreadsheet, pdf file, etc.). Submissions must be kept with the contract documents or in an appropriate computer file and be available for public access. **The form is worded to accept this alternate submission.** The text should be amended if electronic submission will not be allowed.
3. The submission must be **received from the contractor and** on file at least 10 days prior to award of the contract. Resolutions of award should reflect that the disclosure has been received and is on file.
4. The contractor must disclose contributions made to candidate and party committees covering a wide range of public agencies, including all public agencies that have elected officials in the county of the public agency, state legislative positions, and various state entities. The Division of Local Government Services recommends that contractors be provided a list of the affected agencies. This will assist contractors in determining the campaign and political committees of the officials and candidates affected by the disclosure.
 - a) The Division has prepared model disclosure forms for each county. They can be downloaded from the “County PCD Forms” link on the Pay-to-Play web site at https://www.state.nj.us/dca/divisions/dlgs/programs/pay_2_play.html. They will be updated from time-to-time as necessary.
 - b) A public agency using these forms **should edit them to properly reflect the correct legislative district(s)**. As the forms are county-based, **they list all legislative districts** in each county. **Districts that do not represent the public agency should be removed from the lists.**
 - c) Some contractors may find it easier to provide a single list that covers all contributions, regardless of the county. These submissions are appropriate and should be accepted.
 - d) The form may be used “as-is”, subject to edits as described herein.
 - e) The “Contractor Instructions” sheet is intended to be provided with the form. It is recommended that the Instructions and the form be printed on the same piece of paper. The form notes that the Instructions are printed on the back of the form; where that is not the case, the text should be edited accordingly.
 - f) The form is a Word document and can be edited to meet local needs, and posted for download on web sites, used as an e-mail attachment, or provided as a printed document.
5. It is recommended that the contractor also complete a “Stockholder Disclosure Certification.” This will assist the local unit in its obligation to ensure that contractor did not make any prohibited contributions to the committees listed on the Business Entity Disclosure Certification in the 12 months prior to the contract. (See Local Finance Notice 2006-7 for additional information on this obligation) A sample Certification form is part of this package and the instruction to complete it is included in the Contractor Instructions. **NOTE: This section is not applicable to Boards of Education.**

CONTRACTOR INSTRUCTIONS

Business entities (contractors) receiving contracts from a public agency in the state of New Jersey that are NOT awarded pursuant to a "fair and open" process (defined at [N.J.S.A. 19:44A-20.7](#)) are subject to the provisions of P.L. 2005, c. 271, s.2 ([N.J.S.A. 19:44A-20.26](#)). This law provides that 10 days prior to the award of such a contract, the contractor shall disclose contributions to:

- any State, county, or municipal committee of a political party
- any legislative leadership committee*
- any continuing political committee (a.k.a., political action committee)
- any candidate committee of a candidate for, or holder of, an elective office:
 - of the public entity awarding the contract
 - of that county in which that public entity is located
 - of another public entity within that county
 - or of a legislative district in which that public entity is located or, when the public entity is a county, of any legislative district which includes all or part of the county. The disclosure must list reportable contributions to any of the committees that exceed \$300 per election cycle that were made during the 12 months prior to award of the contract. See [N.J.S.A. 19:44A-8](#) and [19:44A-16](#) for more details on reportable contributions.

[N.J.S.A. 19:44A-20.26](#) itemizes the parties from whom contributions must be disclosed when a business entity is not a natural person. This includes the following:

- individuals with an "interest" ownership or control of more than 10% of the profits or assets of a business entity or 10% of the stock in the case of a business entity that is a corporation for profit
- all principals, partners, officers, or directors of the business entity or their spouses
- any subsidiaries directly or indirectly controlled by the business entity
- IRS Code Section 527 New Jersey based organizations, directly or indirectly controlled by the business entity and filing as continuing political committees, (PACs). When the business entity is a natural person, "a contribution by that person's spouse or child, residing therewith, shall be deemed to be a contribution by the business entity." [[N.J.S.A. 19:44A-20.26\(b\)](#)] The contributor must be listed on the disclosure. Any business entity that fails to comply with the disclosure provisions shall be subject to a fine imposed by ELEC in an amount to be determined by the Commission which may be based upon the amount that the business entity failed to report. The enclosed list of agencies is provided to assist the contractor in identifying those public agencies whose elected official and/or candidate campaign committees are affected by the disclosure requirement. It is the contractor's responsibility to identify the specific committees to which contributions may have been made and need to be disclosed. The disclosed information may exceed the minimum requirement. The enclosed form, a content-consistent facsimile, or an electronic data file containing the required details (along with a signed cover sheet) may be used as the contractor's submission and is disclosable to the public under the Open Public Records Act. The contractor must also complete the attached Stockholder Disclosure Certification. This will assist the agency in meeting its obligations under the law.

NOTE: This section does not apply to Board of Education contracts.

¹ [N.J.S.A. 19:44A-3\(s\)](#): "The term "legislative leadership committee" means a committee established, authorized to be established, or designated by the President of the Senate, the Minority Leader of the Senate, the Speaker of the General Assembly or the Minority Leader of the General Assembly pursuant to section 16 of P.L.1993, c.65 (C.19:44A-10.1) for the purpose of receiving contributions and making expenditures."

C. 271 POLITICAL CONTRIBUTION DISCLOSURE FORM

Required Pursuant To [N.J.S.A. 19:44A-20.26](#)

This form or its permitted facsimile must be submitted to the local unit no later than 10 days prior to the award of the contract.

Part I – Vendor Information

List of Agencies with Elected Officials Required for Political Contribution Disclosure

N.J.S.A. 19:44A-20.26

County Name:

State: Governor, and Legislative Leadership Committees

Legislative District #s:

State Senator and two members of the General Assembly per district.

County:

Freeholders

{County Executive}

County Clerk

Surrogate

Sheriff

Municipalities (Mayor and members of governing body, regardless of title):

USERS SHOULD CREATE THEIR OWN FORM, OR DOWNLOAD FROM WWW.NJ.GOV/DCA/LGS/P2P A COUNTY-BASED, CUSTOMIZABLE FORM.

E. Stockholder Disclosure Certification

Name of Business: NPS Public Furniture Corp DBA National Public Seating

I certify that the list below contains the names and home addresses of all stockholders holding 10% or more of the issued and outstanding stock of the undersigned.

OR

I certify that no one stockholder owns 10% or more of the issued and outstanding stock of the undersigned.

Check the box that represents the type of business organization:

- Partnership
- Corporation
- Sole Proprietorship
- Limited Partnership
- Limited Liability Corporation
- Limited Liability Partnership
- Subchapter S Corporation

Sign and notarize the form below, and, if necessary, complete the stockholder list below.

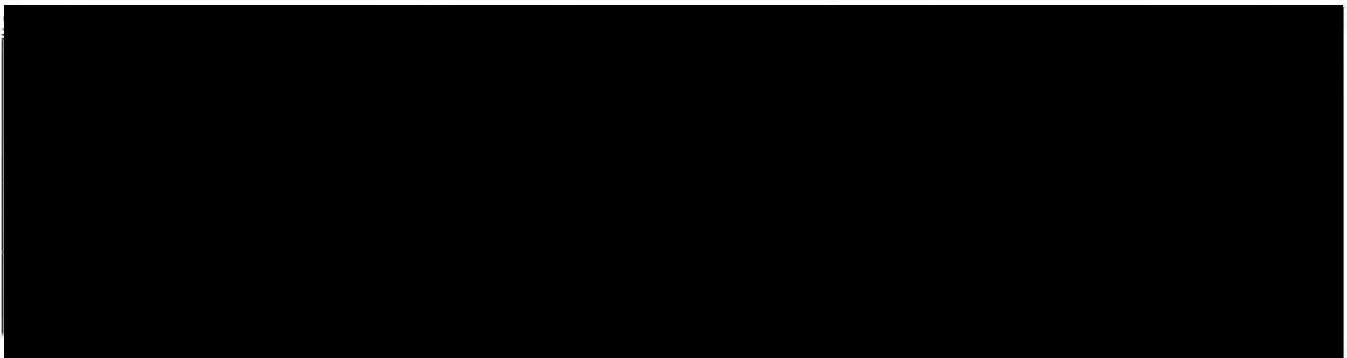

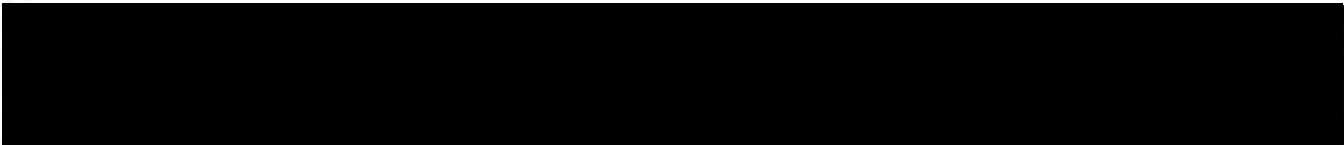

Name: Stockholder Name

Name: Stockholder Name

Home Address:

Home Address:

Home Address

Home Address

Subscribed and sworn before me this 17 day of

November, 2023

(Affiant)

(Notary Public)

CEO Elliot Levy

(Print name & title of affiant)

My Commission expires:

07/01/2024

(Corporate Seal)



PROPOSAL FORM 18: GENERAL TERMS AND CONDITIONS ACCEPTANCE FORM

Check one of the following responses to the General Terms and Conditions in this solicitation, including the Master Agreement:

We take no exceptions/deviations to the general terms and conditions.
(Note: If none are listed below, it is understood that no exceptions/deviations are taken.)

We take the following exceptions/deviations to the general terms and conditions. All exceptions/deviations must be clearly explained. Reference the corresponding general terms and conditions that you are taking exceptions/deviations to. Clearly state if you are adding additions terms and conditions to the general terms and conditions. Provide details on your exceptions/deviations below:

[Click or tap here to enter text.](#)

(Note: Unacceptable exceptions shall remove your proposal from consideration for award. CCOG shall be the sole judge on the acceptance of exceptions/deviations and the decision shall be final.)

PROPOSAL FORM 19: EQUALIS GROUP ADMINISTRATION AGREEMENT DECLARATION

Attachment A - Sample Administration Agreement of this solicitation is for reference only. Contracting with Equalis Group and the Winning Supplier will occur after contract award.

Execution of the Administration Agreement is required for the Master Agreement to be administered by Equalis Group. **Attachment A - Sample Administration Agreement** defines i) the roles and responsibilities of both parties relating to marketing and selling the Program to current and prospective Members, and ii) the financial terms between Equalis Group and Winning Supplier.

Redlined copies of this agreement should not be submitted with the response.

Should a Respondent be recommended for award, this agreement will be negotiated and executed between Equalis Group and the Respondent. Respondents must select one of the following options for submitting their response.

- Respondent agrees to all terms and conditions in **Attachment A - Sample Administration Agreement**.
- Respondent wishes to negotiate directly with Equalis Group on terms and conditions in the Sample Administration Agreement. Negotiations will commence after CCOG has completed contract award.

PROPOSAL FORM 20: MASTER AGREEMENT SIGNATURE FORM

RESPONDENTS MUST SUBMIT THIS FORM COMPLETED AND SIGNED WITH THEIR RESPONSE TO BE CONSIDERED FOR AWARD.

The undersigned hereby proposes and agrees to furnish Products & Services in strict compliance with the terms, specifications, and conditions contained within this RFP and the Master Agreement at the prices proposed within the submitted proposal unless noted in writing. The undersigned further certifies that he/she is an officer of the company and has authority to negotiate and bind the company named below and has not prepared this proposal in collusion with any other Respondent and that the contents of this proposal as to prices, terms or conditions of said proposal have not been communicated by the undersigned nor by any employee or agent to any person engaged in this type of business prior to the official opening of this proposal.

Company Name NPS Public Furniture Corp DBA National Public Seating
Address 149 Entin Road
City/State/Zip Clifton, NJ 07014
Phone Number (800) 261-4112
Email Address usalzman@nationalpublicseating.com
Printed Name Uri Salzman
Job Title Senior Project Manager
Authorized Signature 

Initial Term of the Master Agreement

Contract Effective Date: January 1, 2024
Contract Expiration Date: December 31, 2027
Contract Number: [REDACTED]

(Note: Contract Number will be applied prior to CCOG and Equalis Group countersigning.)

The Cooperative Council of Governments, Inc.
6001 Cochran Road, Suite 333
Cleveland, Ohio 44139

Equalis Group, LLC.
5550 Granite Parkway, Suite 298
Plano, Texas 75024

By: _____
Name: Franklyn A. Corlett
As: CCOG Board President
Date: _____

By: _____
Name: Eric Merkle
As: EVP, Procurement & Operations
Date: _____

Key Contacts

Executive Contact

Elliot Levy | President | (800) 261-4112 x 106 | elliott@nationalpublicseating.com

Years with NPS: 20+

Qualifications: Elliot Levy, President of National Public Seating, is passionate about providing furniture solutions for today's young budding students. He has been with NPS for more than 20 years and has helped the company introduce innovative products & services to meet the ever-changing demand of today's educational environment. Elliot holds an MBA from Johns Hopkins University. He enjoys spending free time with his family, studying ancient history and loves to play Ice Hockey.

Sales Leader

Avi Walles | VP of Sales | (800) 261-4112 x 112 | awalles@nationalpublicseating.com

Years with NPS: 8

Qualifications: Avi joined NPS's sales team in 2015 and assumed the position as Director of Sales in 2017. Under his leadership, NPS has continued to grow by strengthening its dealer relationships and reaching into new markets, all while staying focused on providing the best customer experience possible. Avi holds an MS in Accounting from Fairleigh Dickinson University and resides in Northern New Jersey with his wife and 3 children.

Contract Manager/Reporting Contact/Primary Contact

Uri Salzman | Senior Project Manager | (800) 261-4112 x 154 | usalzman@nationalpublicseating.com

Years with NPS: 8

Qualifications: Uri has been managing our government accounts and contracts for the last 6 years, successfully growing sales in that segment of our business each year. Due to the expertise gained through managing these contract-related accounts, Uri has been assigned the role of Contracts Manager for NPS since mid-2018. Outside of National Public Seating, Uri proudly served on the board of directors for the Albert and Yetta Lupin Memorial Foundation, a private grant-making foundation based in New Orleans, from 2016-2018.

Marketing Contact

Jay Freundlich | VP of Product & CX | (800) 261-4112 x 177 | jfreundlich@nationalpublicseating.com

Years with NPS: 6

Qualifications: Since joining NPS in 2017, Jay has created a multifaceted team skilled in engineering, industrial design, interior design, and graphics. Their mission is to help design, produce and market products that are used in a diverse range of industries every day. The Design & Development team's work enables marketing teams to launch products & initiatives effectively, and engineering teams to iterate with confidence.

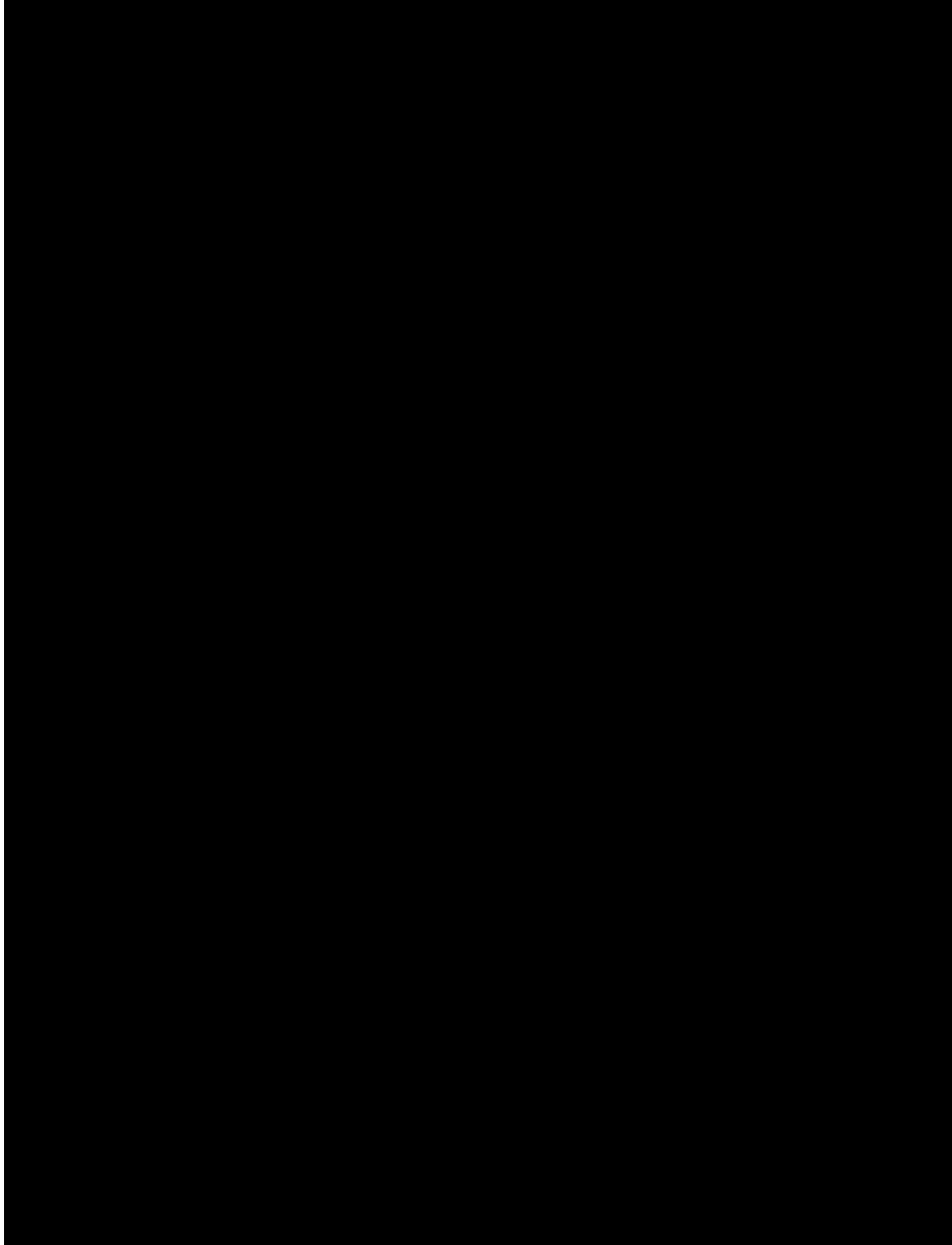

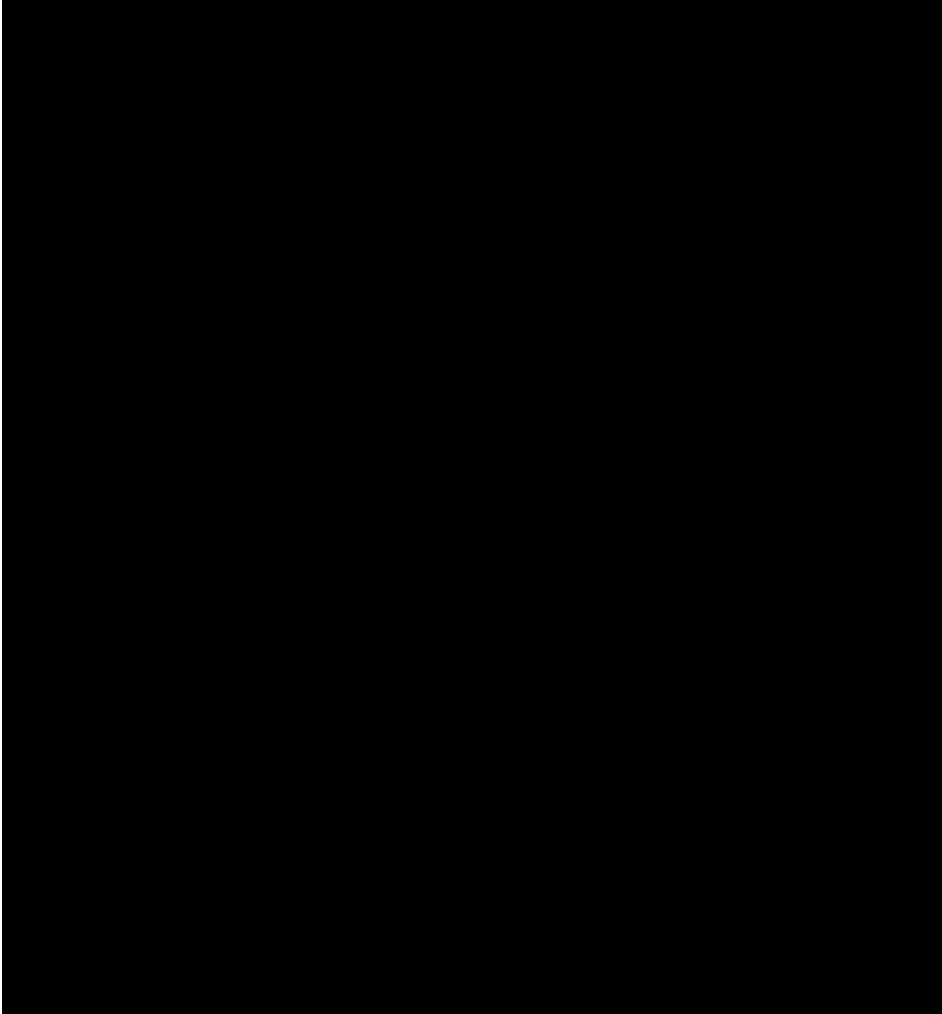

Trade Secret Elements of Response

We kindly request that the following response sections be redacted:

Section: Technical Proposal

Element: Financial_Stability_Letter_2023.pdf

Reason: As a privately held corporation we request that financial data be kept confidential.

Section: Technical Proposal

Element: References.pdf

Reason: We request that customer data be kept confidential.

Section: Technical Proposal

Element: Responses to 1.4.1, 1.4.2 and 1.4.3

Reason: As a privately held corporation we request that financial data be kept confidential.

Section: Proposal Form 17

Element: Sections A and E

Reason: As a privately held corporation we request that ownership information be kept confidential.



MANUFACTURER'S WARRANTY

National Public Seating® provides a warranty to the original user, covering all manufacturing defects in material and workmanship from the date of purchase for a period of ten years*. In the event of a defect, NPS will, at its discretion, either repair or replace the defective product. This warranty does not cover damage resulting from misuse, abuse, or neglect. Please note that excessive swaying back and forth on any banquet stack chair will completely void the warranty. To initiate a return or request repairs, you must contact your dealer for authorization. This warranty grants you specific rights, and you may also have additional rights that vary by state.

The warranty for butcherblock tabletops is limited to one year due to the fact that the lifespan of natural wood surfaces heavily depends on maintenance, refinishing, and storage. However, the standard 10-year warranty still applies to the overall product, including all other table parts.

Orders are accepted under the express agreement that under no circumstances will seller be liable for any incidental or consequential damages, or for any other loss, damage or expense of any kind, including loss of profits, arising in connection with the order or with the use or inability to use seller's products furnished under the order. Seller's maximum liability shall not exceed and buyer's remedy is limited to either (i) repair or replacement of the defective part or product, or at seller's option (ii) return of the product and refund of the purchase price. Such remedy shall be the buyer's entire and exclusive remedy.

**Fifteen years on Mobile Cafeteria Tables*

**One year for natural wood surfaces (butcherblock)*

**One year for Basics by NPS*



Environmental Initiatives

- ❖ All of the steel for our products contains 30-40% of post-consumer waste.
- ❖ Corrugated containers are made of recycled fiber. 100% total recycled content and 90% post-consumer content minimum.
- ❖ Our plastic products contain up to 35% of pre-consumer waste.
- ❖ 100% of wood used for our products comes from non-boreal forests.
- ❖ Our products are powder coated and are highly protective to our environment. While liquid finishes contain solvents which have pollutants known as volatile organic compounds (VOCs), powder coating contains no solvents and releases negligible amounts, if any, of VOCs into the atmosphere. In addition, most powder coating overspray that does not adhere to the part is retrieved and reused, virtually eliminating the waste commonly found in liquid finishing processes.
- ❖ Our Folding Chairs are manufactured within ANSI BIFMA X7.1 2007 VOC Air Emission guidelines; Criteria #1 – TVOC, Formaldehyde, All Aldehydes & 4-Phenylcyclohexene.
- ❖ During November 2008, National Public Seating®, completed a retrofit of all its lighting (over 800 fixtures), to eco-friendly units, saving 135,586 kWh annually. This reduction in energy consumption has an environmental impact equivalent to removing 20 cars from the road, 84 tons of greenhouse gas (CO₂) and saving 198 barrels of oil annually!
- ❖ NPS® is also proud to have completed a major solar panel installation on the roof of its 200,000 square foot factory in Clifton, NJ, during Summer 2011. Via the installation of a 240KW solar PV system on its roof, we will offset most of the local utility's need to burn oil and gas for electrical production in the public grid and therefore reduce greenhouse gas emissions into the atmosphere. Since we will be generating 80% of the electricity that we use with this system, we have cut our carbon footprint significantly.
- ❖ The entire NPS® Product Line is now MAS Certified Green™, a nationally recognized registered trademark delineating low VOC emitting products in the marketplace so that purchasers and specifiers of those products know that they can earn credits in sustainability programs like LEED, BIFMA's Level, and California CHP program.

FURNISHING EDUCATIONAL SPACES SINCE 1981



CAFETERIA



SCIENCE LAB



MUSIC ROOM



AUDITORIUM



OUR STORY



**Industrial
Grade Product
Solutions**



**Built with
Engineering
Excellence**



**Signature
Service**

NPS outfits industries across the country with no-fail equipment they use every single day.

In 1981 Oklahoma Sound opened its doors, recognizing an unmet need in the furniture industry. Podiums that worked well and lasted for years. We sought to build cabinetry that would perform through decades of wear and tear, pieces designed with schools, worship centers, and organizations in mind. And so, with a few helping hands, we got to work manufacturing every element of the furniture in house. That's right, not just the cabinetry, but the speakers and amplifiers were built from scratch. It seemed the best way to take real ownership of the end product.

The results were powerful and organizations came back asking for more. Chairs, this time. The team obliged, and in 1997 National Public Seating was born. Now, NPS outfits spaces across the country with no-fail furniture they use every single day. From ultra-breathable flex chairs to easy-expand tables on wheels, our products are innovative, solution-focused, and both durable and comfortable to the nth degree. We ship them out quickly because we know time is of the essence, and we do everything possible to give you, our customers, a smooth experience from first purchase to years down the line.



A PASSION FOR EDUCATION

Furnishing schools is our passion. Of course, we love providing every industry with the tools it needs to succeed, but sustaining the learning and development of America's future leaders is where we shine brightest. Students sit most of the day. If they aren't comfortable they'll fidget and won't be happy to learn. It's that basic. That's why making strong, feelgood furniture for schools is our focal point. We proudly equip art rooms, music rooms, science labs, auditoriums, and cafeterias with sturdy tables, supportive chairs, and hardwood lecterns designed to truly last.



INDUSTRIAL GRADE

All our products are industrial grade, and that means they're crafted for heavy-duty usage day in, day out. We don't cut corners and we don't mess around. Our team of engineers and designers develop the furniture in our New Jersey plant, supported by 90+ factory employees. The furniture is then put through rigorous quality control testing to ensure it meets and surpasses every industry standard. We are there at every step in the manufacturing process.



SIGNATURE SERVICE

Our sales team doesn't rest on its laurels. It is constantly finding new ways to better streamline the supply process. The shipping team gets orders on the road in hours, and with warehouses in California, Tennessee and New Jersey, shipments often arrive the next day. Believe it or not, our customer service representatives look forward to solving any issue that should crop up. Because that's what they're there for. That's not all, though. Thanks to our custom design services, reliable web support, no-questions-asked returns and repairs, and ten year warranty, our dealers have come to know and deeply trust our service for 40 years. Here's to many more!



Hand Sketch Concept



NPS 2D Drawing

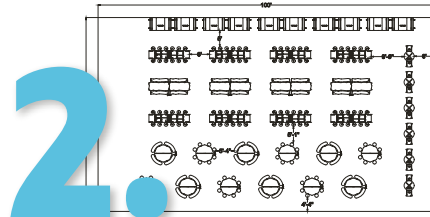

NPS 3D Rendering

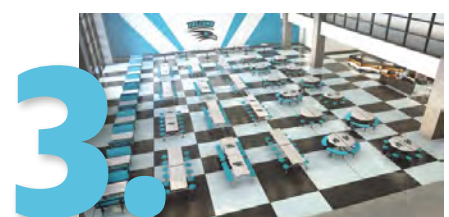



NPS DESIGN SERVICES You think it. We create it.

Our products are
featured on
leading design
software



TABLE OF CONTENTS

10 FOLDING CHAIRS



20 STACK CHAIRS



32 STOOLS



54 WOOD FOLDING TABLES



60 STEEL TABLES



68 SCIENCE TABLES



86 MOBILE TABLES



113 CAFÉ



122 MUSIC



134 STAGES & RISERS

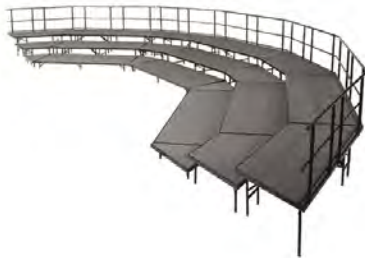

143 DOLLIES



152 LECTERNS



168 CHARGING CARTS



169 PA SYSTEMS



172 BASICS BY NPS

BASICS
by NPS

44

PLASTIC FOLDING TABLES



80

WORKSTATIONS



130

ROOM DIVIDERS



165

PRESENTATION CARTS



177

DESIGN OPTIONS



Quickship Available

For Most Products



Online Dealer Support

- Price Lists
- Freight Quotes
- Order Tracking
- Assembly Instructions
- Service Portal



Online Image Library



Expansive Online Product Videos



State and Regional
Government Contracts



Offering TAA Compliant Products



Parts under \$25

Ship to End Users with No Charge



Now offering full design services!



GENERAL PRODUCTS



MOBILE TABLES



BASICS BY NPS



MADE IN NJ, USA



Our entire product line is MAS Certified Green®. For more information, visit www.mascertifiedgreen.com





FOLDING CHAIRS

Steel Chairs

50, 200, 300,
5200



Upholstered Chairs

1200, 1300, 2200,
2300, 3200



Plastic Chairs

600, 800,
1100, 1400



All-Steel

Standard | Double Brace | Single Hinge | 19-Gauge Frame
50 Series



Premium | Double Brace | Double Hinge | 18-Gauge Frame
200 Series



TAA ✓



Colors



Beige
51



Grey
52



Black
510

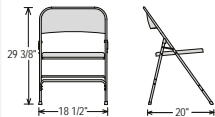

Colors



Beige
201



Grey
202



Brown
203



Char-Blue
204



Black
210



Red
240

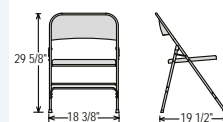

Shared Features

Available Accessories



PGC1

Ganging Device for Models
50 · 200 · 300 · 800 · 1100
· 1200 · 1300 · 2200 · 2300
· 3200 · 5200



MGC

Ganging Device for Models
50 · 200 · 300 · 800 · 1100
· 1200 · 1300 · 2200 · 2300
· 3200



GL

Glides for Models
50 · 200 · 300 · 800 · 1100 ·
1200 · 1300 · 2200 · 2300 ·
3200 · 5200



VT

V-Tips for Models
50 · 200 · 300 · 800 · 1100 ·
1200 · 1300 · 2200 · 2300 ·
3200 · 5200

**THE
Body
Builder
LINE**

Premium | Triple-Brace | Double Hinge | 18-Gauge Frame
300 Series



Premium All-Steel with Tablet Arm | Double Hinge
5200 Series



TAA ✓

2 DAY
LIGHTNING SHIP

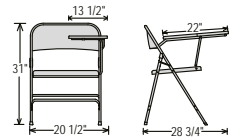

Colors

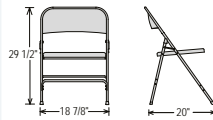

Colors



Grey Tablet Arm
Black Frame
5210R (right handed)
5210L (left handed)

Features



Extended Tablet
Provides Extra
Writing Space



Ultra-Strong Triangular
Gorilla Bracket Adds
Superior Durability

*5200 Cannot Be Transported on Dollies

Shared Features

All Steel Features



Non-Marring
Replaceable Glides That
Match Frame Color



Back Leg
Stability
Plugs



Double
Riveted U
Brace



2 1/4" Frame
Strengthener



Vinyl Upholstered

Double Brace | Double Hinge
1200 Series



Triple U Brace | Double Hinge
1300 Series



TAA ✓



Colors

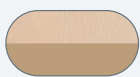

French Beige Vinyl
Beige Frame
1201 / 1301



Warm Grey Vinyl
Grey Frame
1202 / 1302



Dark Midnight Blue Vinyl
Char-Blue Frame
1204 / 1304



Caviar Black Vinyl
Black Frame
1210 / 1310



Honey Brown Vinyl
Beige Frame
1203

Shared Features

Vinyl and Fabric Features



Non-Marring
Replaceable Glides That
Match Frame Color



Back Leg
Stability
Plugs



Double
Riveted U
Brace



2 1/4" Frame
Strengthener



Upholstered
Seat and Back



Double Hinge

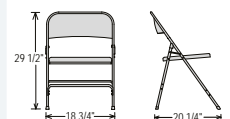

Double Brace | Double Hinge
 2200 Series



Triple U Brace | Double Hinge
 2300 Series



Colors



Cafe Beige Fabric
 Beige Frame
 2201 / 2301



Greystone Fabric
 Grey Frame
 2202 / 2302



Russet Walnut Fabric
 Brown Frame
 2207



Imperial Blue Fabric
 Char-Blue Frame
 2204 / 2304



Midnight Black Fabric
 Black Frame
 2210 / 2310



Majestic Cabernet Fabric
 Grey Frame
 2208/2308



Imperial Blue Fabric
 Grey Frame
 2205

Shared Features



products meet or exceed applicable ANSI/BIFMA standards



Folding Chairs

2" Upholstered Fabric/Vinyl Seat
3200 Series



2 DAY
LIGHTNING SHIP



Blow Molded
600 Series



Fabric Colors

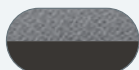

Charcoal Grey Fabric
Black Frame
3212

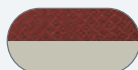

New Burgundy Fabric
Grey Frame
3218

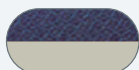

Regal Blue Fabric
Grey Frame
3215



Antique Gold Fabric
Brown Frame
3219

Vinyl Colors



Beige Vinyl
Beige Frame
3201



Black Vinyl
Black Frame
3210

Colors

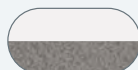

Speckled Grey Plastic
Grey Hammer Tone Frame
602



Blue Plastic
Black Frame
604



Black Plastic
Black Frame
610

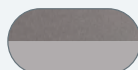

Charcoal Slate Plastic
Silvertone Frame
620



Red Plastic
Black Frame
640

Features



2" Ultra Comfort
Box Seat



High Backrest

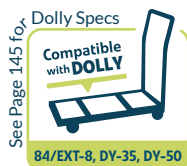
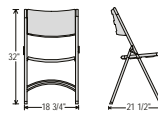
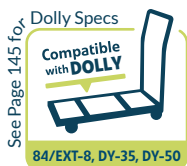
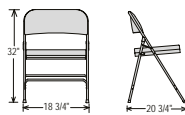

Features



19-Gauge
Steel Frame



Fully Welded
U Brace

**Premium Plastic Lightweight
800 Series**



**SUPER
STACKER**

**2 DAY
LIGHTNING SHIP**

**Polyfold Fan Back Triple-Trace
1100 Series**



**SUPER
STACKER**

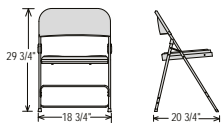

TAA ✓

See Page 145 for Dolly Specs
Compatible with **DOLLY**
84, DY700/800,
DY-35, DY-50

Colors

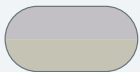

Grey Plastic
Grey Frame
802



Blue Plastic
Grey Frame
805



Black Plastic
Black Frame
810



Burgundy Plastic
Black Frame
818

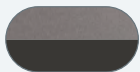

Charcoal Slate Plastic
Black Frame
820



White Plastic
White Frame
821

**CAL-133
RATED**

**24 HOUR LOAD TEST
500
lbs**
TESTED BY
**BUREAU
VERITAS**

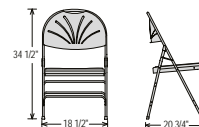

See Page 145 for Dolly Specs
Compatible with **DOLLY**
84/EXT-8, DY35,
DY-50, DY1100

Colors



Blue Plastic
Grey Frame
1105



Black Plastic
Black Frame
1110



Dark Blue Plastic
Grey Frame
1115

Features



18-Gauge
Steel Frame



Double Riveted
U Brace



7/8" Round
Tubular Frame



Non-Marring
Polypropylene Glides



Double Hinge

**See Available
Accessories on
PAGE 10**



ten year
warranty
10

**BIFMA
INTERNATIONAL
ANSI**

products meet
or exceed applicable
ANSI/BIFMA standards

AirFlex®



COMFORT

Distinct AirFlex® Design
Contours to Each Individual
Making for the Perfect Balance
of Comfort and Strength.



DESIGN

Modern Design
Enhances Any Event.

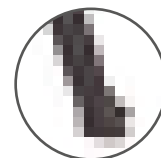

DURABILITY

Strong 18-Gauge Steel Frame
and Seat Supports Make for
Long Lasting Durability.



See Page 145 for Dolly Specs

Compatible with DOLLY

84/EXT-8, DY1400

Features



Durable Industrial Grade 3.8MM Polypropylene



Seat Strengthened With Two 11-Gauge Steel Side Supports



Sweat-Free Ventilation



18-Gauge Steel Frame



7/8" Square Leg Tubing for Added Strength



Oversized 18"D Seat



Backrest Secured With Rivets

Colors



Black 1410

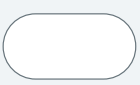

White 1421

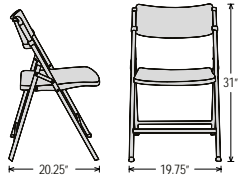

AirFlex® Dimensions
 Overall: 31" H x 19.75" W x 20.25" D
 Folded: 40.25" H x 19.50" W x 2" D
 Seat: 17.25" H x 17" W x 18" D
 Back: 7.5" H x 19.5" W
 Weight: 9.6 lbs.



products meet or exceed applicable ANSI/BIFMA standards





STACK CHAIRS



Stack Chairs

8100, 8500, 8600, 8700,
8800, LuvraFlex

Polyshell Stacker
8100 Series



Stacks
10
CHAIRS

See Page 147 for
Dolly Specs
Compatible
with **DOLLY**
DY-81

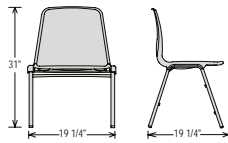

Features



High-Density
Injection Molded Poly
One-Piece Shell



Frame Shields Protect
Against Snags and
Pinching



Strong 17-Gauge
7/8" Square
Tubing

Colors

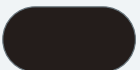

Black
8110



Blue
8125



Available Accessories



TA81R*
Oak Surface
Left Tablet Arm



TA81R*
Oak Surface
Right Tablet Arm



PGC81
Ganging Device

*Chairs can't be stacked with tablet arms attached

Signature Stacker
8600 Series



Stacks
20
CHAIRS

See Page 148 for
Dolly Specs
Compatible
with **DOLLY**
DY-86

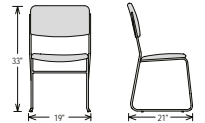

Features



Strong 16-Gauge
1/2" Round Tubing



Contoured Seat and Back
for Enhanced Comfort



Non-Marring
Floor Glides

Colors



Ebony Black
8660



Classic Grey
8652

Accessories



MGC86
Ganging Device



products meet
or exceed applicable
ANSI/BIFMA standards



Black Frame / Black Fabric Also
Available as Custom Order for 8600

Hi Tech Ultra Compact Stacker
8500 Series



Features



Molded Seat and Back Provide Comfort and Allow for Easy Interstacking



Protective Rounded Polycarbonate Floor Glides With Custom Clamping Device



Reinforced Underseat Ribbing for Added Strength



Chrome-Plated 11mm Steel Rod Frame

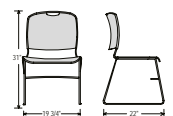

products meet or exceed applicable ANSI/BIFMA standards



Colors



Wine
8508



Black
8510



Gunmetal Grey
8502



Navy Blue
8505

Available Accessories



TA85L*
Black Left
Tablet Arm



TA85R*
Black Right
Tablet Arm



BR85
Book Basket



PGC85
Ganging Device

*Chairs can't be stacked with tablet arms attached



Stacks
40
CHAIRS



See Page 147 for





See Page 25 for Custom Color Options

Standard Colors

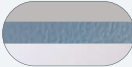
-  8704-10-04
Blue Poly and Blue Vinyl
Black Frame
-  8710-11-10
Black Poly and Black Vinyl
Chrome Frame
-  8742-12-02
Grey Poly and Blue Vinyl
Silver Frame



See Page 25 for Custom Color Options

Standard Colors

-  8710C-11-10
Black Poly and Black Vinyl
Chrome Frame

24"
SEAT
HEIGHT



See Page 25 for Custom Color Options

Standard Colors

-  8710B-11-10
Black Poly and Black Vinyl
Chrome Frame

30"
SEAT
HEIGHT

Chair Features 8700/8800



"Rod In Tube"
Design



Glides Function as
Built-in Gangers for
Multi Chair Setup



Polypropylene Plastic
Back Design Provides
Ergonomic Support



Glides Are Made
of TPU For
Sensitive Floors



See Page 148 for
Dolly Specs
Compatible
with DOLLY
DY-87

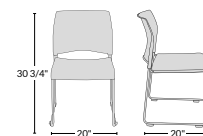

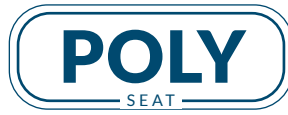

STACK CHAIRS | 8800 SERIES Poly Cafetorium Chair



See Page 25 for Custom Color Options

Standard Colors

- 8804-11-04
Blue Poly Chrome Frame
- 8810-11-10
Black Poly Chrome Frame
- 8820-11-20
Charcoal Poly Chrome Frame



See Page 25 for Custom Color Options

Standard Colors

- 8810C-11-10
Black Poly Chrome Frame

24" SEAT HEIGHT



See Page 25 for Custom Color Options

Standard Colors

- 8810B-11-10
Black Poly Chrome Frame

30" SEAT HEIGHT

Bar Stool Features 8700/8800



Plastic Stacking Bumpers



Welded Footrest



7/8" Leg Tubing



Glides

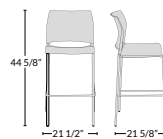



Features



Solid Rod Frame Design



Transparent Glides Feature a Felt Base for Floor Protection



Flex Back Tested by SGS Labs to Resist 425 Lbs of Force



Unique Design for Ultimate Seating Comfort



Glides Function as Built-in Gangers for Multi Chair Setup



See Facing Page for Custom Color Options

Standard Poly Colors



LVC04-10
Blue Poly
Black Frame



LVC10-11
Black Poly
Chrome Frame

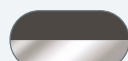

LVC20-11
Charcoal Poly
Chrome Frame

See Facing Page for Custom Color Options

Standard Vinyl Colors

add vinyl code to the end of poly chair model number



04
Blue



10
Black

Model Number Configuration

Poly Chair Model Number

LVC04-10-10

Vinyl Seat Color (if applicable)



products meet or exceed applicable ANSI/BIFMA standards



8700/8800/LuvraFlex Custom Colors

Custom Color Options

300 Chair MOQ and Extended Lead Times Apply

Frame Colors



Available for 8700/8800 and LuvraFlex

Poly



Available for 8700 and LuvraFlex

Vinyl

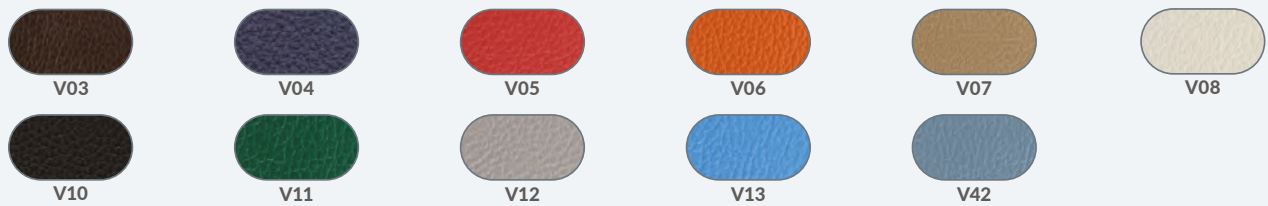

Available for 8700 and LuvraFlex

Fabric



8700/8800 Custom Configuration

Model Number Frame Color
87* PXX-XX-PXX
 Seat Color Back Color

*Add B for Bar Height or C for Counter Height



LuvraFlex Custom Configuration

Model Number Frame Color
LVC PXX-XX-VXX
 Poly Color Vinyl/Fabric Seat Color (if applicable)

BANQUET CHAIRS



Banquet Chairs

Dome Back
9200 Series



Silhouette Back
9300 Series



Stacks
10
CHAIRS



See Page 147 for Dolly Specs

Compatible with DOLLY

DY81, DY-9000



Standard Colors



See Page 180 for Custom Color Options



9254-SV
Midnight Blue Fabric
Silvervein Frame



9201-M
French Beige Vinyl
Mocha Frame



9254-BT
Midnight Blue Fabric
Black Santex Frame



9204-SV
Midnight Blue Vinyl
Silvervein Frame



9260-SV
Ebony Black Fabric
Silvervein Frame



9204-BT
Midnight Blue Vinyl
Black Santex Frame



9260-BT
Ebony Black Fabric
Black Santex Frame



9210-SV
Panther Black Vinyl
Silvervein Frame



9210-BT
Panther Black Vinyl
Black Santex Frame

Standard Colors



See Page 180 for Custom Color Options



9304-SV
Midnight Blue Vinyl
Silvervein Frame



9362-BT
Natural Greystone Fabric
Black Santex Frame



9310-BT
Panther Black Vinyl
Black Santex Frame



9364-SV
Diamond Navy Fabric
Silvervein Frame



9354-SV
Midnight Blue Fabric
Silvervein Frame



9374-BT
Natural Blue Fabric
Black Santex Frame



9360-BT
Ebony Black Fabric
Black Santex Frame



9378-BT
Natural Taupe Fabric
Black Santex Frame



9361-BT
Natural Chocolatier Fabric
Black Santex Frame

Features



2" 1.8lb. High-Density Grade A Foam Waterfall Seat

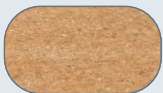

MDF Core Seat and Back



Stacking Bars And 12 Plastic Stack Bumpers Ensure Stacking Securely



7/8" Square 18 Gauge Tubing With Non-Marring Glides 5/8" Underseat H Braces

9200

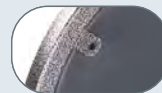

Back Rests On 4 Tabs For Extra Durability

9300



Premium Double Back Conceals 4 Steel Backrest Tabs

CAL-117
RATED

ten year warranty
10

BIFMA
INTERNATIONAL

ANSI

products meet or exceed applicable ANSI/BIFMA standards

MADE IN THE USA
GREEN
certified green

MOBILE CHAIRS



MOBILE CHAIRS | COGO SERIES
CoGo Mobile Tablet Chair
 Modern chair for today's collaborative learning!



DESIGN

Ergonomically Designed For All-Day Seating Support; Contemporary Design Enhances the Modern Classroom.



MOBILITY

Allows Students to Move to Different Learning Areas With Ease.



DURABILITY

16 Gauge Steel and Twin 2 Inch Casters for Long-Lasting Classroom Use.



Features



Strong Twin Wheeled 2" Casters



Fiberglass-Reinforced Polypropylene

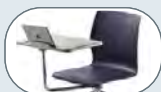

Tablet Can Be Installed on the Right or Left Side

Seat Colors



Black
COGO-10



Blue
COGO-04



Red
COGO-40

Available Accessory



GLCOGO
Set of Four Glides



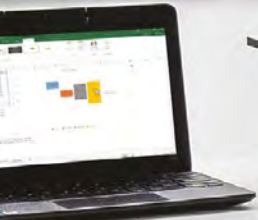
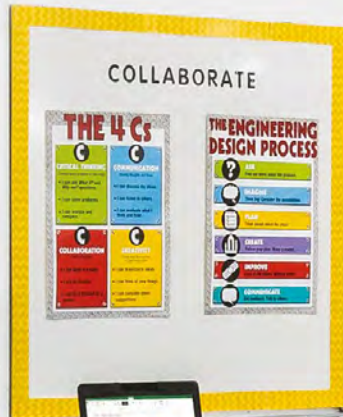

STOOLS



Stools
6200, 6300,
6400, 6500



**Designer
Stools**
6600, 6800,
Titan



**Task Chairs
and Stools**
6700, CTC



Heavy-Duty Masonite Seat Stools

Features



16 Rivets on Seat To Ensure Longevity



Four Weld Points at Each Leg for Extreme Durability



Industrial Grade Glides



Heavy-Duty 18-Gauge 7/8" Steel Tubing



Add-on Backrest Adjusts 2" Up/Down and 2" Forward/Back



Add-on Chromed Adjustable Height Inserts Adjust to Nine Heights



STANDARD



BACKREST



ADJUSTABLE HEIGHT



ADJUSTABLE HEIGHT & BACKREST



Model # Seat Height

6318	18"
6324	24"
6330	30"
6318H	19-27"
6324H	25-33"
6330H	32-39"

Model Number Configuration

Model Number Add-on Code (if applicable)
6318H

Frame Colors



Grey

Seat Color



Masonite

Add-on Codes

Backrest	B
Adjustable Height	H
Adjustable Height and Backrest	HB

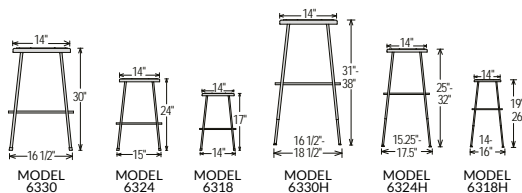

Heavy-Duty Padded Stools

Features

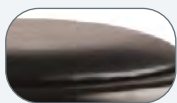

Padded Vinyl Seat



Heavy-Duty 18-Gauge 7/8" Steel Tubing



Industrial Grade Glides

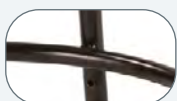

Four Weld Points at Each Leg for Extreme Durability



Add-on Backrest Adjusts 2" Up/Down and 2" Forward/Back



Add-on Chromed Adjustable Height Inserts Adjust to Nine Heights



STANDARD



BACKREST



ADJUSTABLE HEIGHT



ADJUSTABLE HEIGHT & BACKREST



Model # Seat Height

6418	18"
6424	24"
6430	30"
6418H	19-27"
6424H	25-33"
6430H	32-39"

Model Number Configuration



Frame Colors

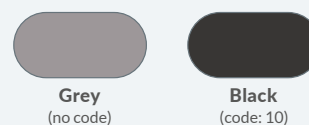

Seat Color



Add-on Codes

Backrest	B
Adjustable Height	H
Adjustable Height and Backrest	HB

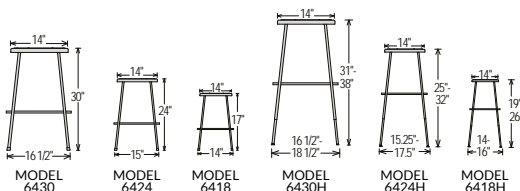

products meet or exceed applicable ANSI/BIFMA standards

STOOLS | 6500 SERIES
Heavy-Duty Padded Stools

Features



Height Adjustable from 24"-30"



1/2" Vinyl Padded Riveted Thru the Steel Seat Pan



7/8" O.D. 16-Gauge Steel Tubing



Foot Rings, 5/8" O.D. Welded to Each Leg



Add-on Backrest Adjusts 2" Up/Down and 2" Forward/Back



Stool Color

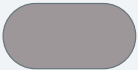

Grey

Model #	Height	Description
6524HB	24-30"	Stool with Backrest
6524H	24-30"	Stool without Backrest

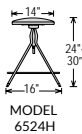
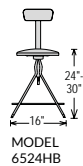

products meet or exceed applicable ANSI/BIFMA standards

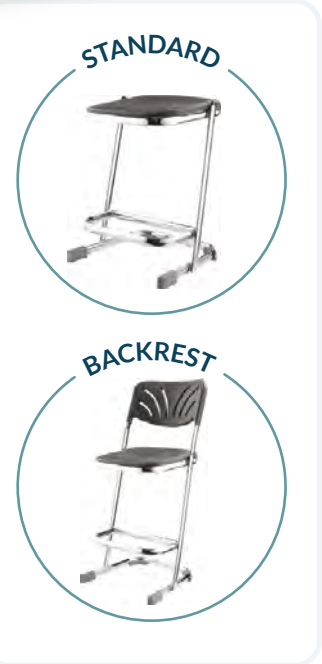

Model Number Configuration



Model # Seat Height

6618	18"
6622	22"
6624	24"



products meet or exceed applicable ANSI/BIFMA standards

Features



Additional Weld on Bottom for Added Strength



Riveted Glides For Added Stability



Conveniently Stackable



Optional Fan-Back For Extra Comfort



14 Gauge Eye-Tubular Steel Frame



Nests on Tabletops For Easy Cleanup and Storage!



Ergonomic Blow Molded Seat Provides Maximum Comfort



Embedded Thermoplastic Polyurethane TPU Glides Provide Quiet and Smooth Gliding On All Floor Types



Oversized Contact Area For Extreme Stability



Rear Brace For Added Strength



Built in 4" Height Footrest With a 15" Diameter

6622/6624

TITAN STOOL



Comfort Task Chair and Stool

Comfort Task Stool

Comfort Task Chair



360°

TAA ✓

2 DAY LIGHTNING SHIP

Fabric tested to EXCEED 70,000 double rubs

WEIGHT CAPACITY 300 lbs



360°

Features



Plush Padded Seat And Back



Includes Five 2" Industrial Grade Casters and Mushroom Glides

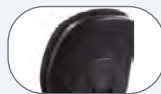

Plastic Reinforced Backrest and Seat

Add-On



Optional Adjustable Height Armrest

Model # Description

CTC	18"-22" (Glides) 19"-23" (Casters) Comfort Task Chair
CTC-A	18"-22" (Glides) 19"-23" (Casters) Comfort Task Chair with Adjustable Height Armrests
CTS	24.5"-34.5" (Glides) 25.5"-35.5" (Casters) Comfort Task Stool
CTS-A	24.5"-34.5" (Glides) 25.5"-35.5" (Casters) Comfort Task Stool with Adjustable Height Armrests

CAL-117 RATED

MADE CERTIFIED GREEN

ten year warranty 10

BIFMA INTERNATIONAL ANSI

products meet or exceed applicable ANSI/BIFMA standards

Polyurethane Task Chair



Polyurethane Task Stool



**2 DAY
 LIGHTNING SHIP**



Features



Convenient Backrest Handhold for Maneuverability



Includes Five 2" Industrial Grade Casters and Mushroom Glides



Backrest Tilt

Add-On



Optional Adjustable Height Armrest

Model #	Description
6716HB	16"-21" Polyurethane Chair (desk height)
6722HB	22"-32" Polyurethane Stool
6716HB-A	16"-21" Polyurethane Chair (desk height) with Adjustable Height Armrests
6722HB-A	22"-32" Polyurethane Stool with Adjustable Height Armrests



products meet or exceed applicable ANSI/BIFMA standards





PLASTIC FOLDING TABLES

**Plastic
Folding Tables**
1800, 2400, 3000, 3600,
BTA, BTR, BMFIH, BPFT



PLASTIC FOLDING TABLES | 1800 SERIES

Seminar Tables



The perfect solution for your banquet & cafeteria use – indoor, outdoor, or any other application that calls for affordable, lightweight, weather resistant and highly durable folding tables.



See Page 143 for Dolly Specs

Compatible with **DOLLY**

TAD, DYMU

THREE SIZES AVAILABLE

Colors



Speckled Grey Plastic
Grey Hammer Tone
Frame

Features



Unique Spring-Loaded Lock For Complete Stability



2" Thick UV Protected Tabletop



Textured Tabletop Surface Smooth Enough For Writing

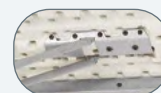

Industrial Grade Framing System



16-Gauge Cantilever Comfort Legs

Model # Size

BT1860	18"x60"
BT1872	18"x72"
BT1896	18"x96"

can withstand heat up to **212°**

2 DAY LIGHTNING SHIP

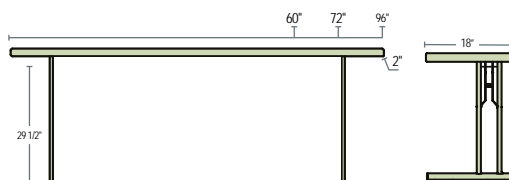

WEIGHT CAPACITY
700 lbs

evenly distributed

ten year warranty
10

CERTIFIED GREEN
100% Recycled Material

BIFMA INTERNATIONAL
ANSI

products meet or exceed applicable ANSI/BIFMA standards

Blow Molded Folding Tables

See Page 143 for Dolly Specs
Compatible with **DOLLY**
TAD, DYMU



Features



17-Gauge Framing System



Built In Handle For Easy Lifting



Extra Stable Gravity Lock

Colors



Speckled Grey Plastic
Grey Hammer Tone Frame

Model Number
BT2448

can withstand heat up to **212°**

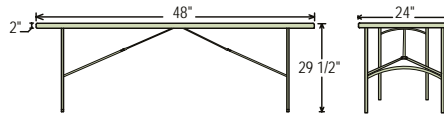

products meet or exceed applicable ANSI/BIFMA standards



Features



19-Gauge Framing System



Attractive Arched Tube Leg Connectors For Added Strength

can withstand heat up to **212°**

Model Number
BT3636

Colors

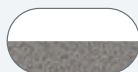

Speckled Grey Plastic
Grey Hammer Tone Frame

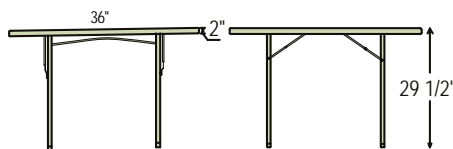

products meet or exceed applicable ANSI/BIFMA standards



PLASTIC FOLDING TABLES | BT3000 SERIES
Blow Molded Folding Tables



See Page 143 for Dolly Specs
 Compatible with DOLLY
 TAD, DYMU, DY3072/DY3096



BT3072-20



Features



18-Gauge Legs



17-Gauge Framing System



Heavy Duty Wishbone Leg Structure



Extra Stable Gravity Lock

Colors



BT3000 series
 Speckled Grey Plastic
 Grey Hammer Tone Frame



BT3072-20 series
 Charcoal Slate Plastic
 Silvertone Frame (30"x72" only)

Model #	Size
BT3060	30"x60"
BT3072*	30"x72"
BT3096	30"x96"

*add -20 for Charcoal Slate

THREE SIZES AVAILABLE

can withstand heat up to **212°**



BT3060/BT3072



evenly distributed

BT3096



evenly distributed



products meet or exceed applicable ANSI/BIFMA standards

Brighten up your room to create a complete portable Furniture Suite, with these attractive, affordable, Quick Ship Tables!



Features



Lightweight 37lbs For Easy Setup and Transport



Adjustable Height From 22-28.5"

Colors



BTA-3072-40
Red Plastic
Black Frame



BTA-3072-04
Blue Plastic
Black Frame

See Page 143 for Dolly Specs
Compatible with DOLLY
TAD, DYMU, DY3072/DY3096

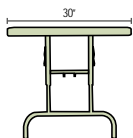
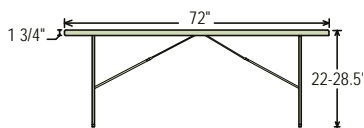

evenly distributed



products meet or exceed applicable ANSI/BIFMA standards

Round Folding Tables



The perfect solution for your banquet & cafeteria use – indoor, outdoor, or any other application that calls for affordable, lightweight, weather resistant and highly durable folding tables.



See Page 144 for Dolly Specs
Compatible with **DOLLY**
DY-60R, DY-71R, DYMU

2 DAY LIGHTNING SHIP

can withstand heat up to **212°**

Features

All Round Tables		BT48R/BT71R		BT60R	
	Gravity Lock		2" Thick UV Protected Tabletop		19-Gauge Framing System
	700 LBS Weight Capacity		17-Gauge Framing System		1000 LBS Weight Capacity

Colors



Speckled Grey Plastic
Grey Hammer Tone Frame

Model #	Size
BT48R	48"
BT60R	60"
BT71R	71"

THREE SIZES AVAILABLE

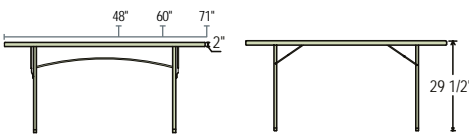

ten year warranty
10



PLASTIC FOLDING TABLES | BMFIH SERIES
Fold in Half Tables



Features



Automatic Locking Device for Safe Setup



1.5" High-Density Polyethylene (HDPE) Top



Gravity Lock



First of Its Kind! Rounded Ends and Oblique Edges.



No Cross Bar Allows for Additional Seating At The End Of The Table



Powder-Coated 19-Gauge Steel Frame



Convenient Carrying Handle for Easy Transport



Lightweight 37lbs for Easy Setup and Transport

Colors



Speckled Grey Plastic
 Grey Hammer Tone Frame



Open dimensions:
 71.8"L x 30"W x 29.5"H
 Folded dimensions:
 36"L x 30"W x 3.75"D



evenly distributed

Model Number
BMFIH3072

can withstand heat up to
212°



products meet or exceed applicable ANSIBIFMA standards



Roll In



Flip



Store



Features



Frame and Legs Are Made With Industrial Grade Powdercoated Steel



Perforated Steel Modesty Panel With a Built-in Cable Channel To Conceal Wires



Four 2" Casters (Two Locking) Enable Tables to Roll With Ease



Lightweight 37lbs for Easy Setup and Transport



Two Grommet Holes for Wire Management



Tables Nest for Easy Storage



Use Lever to Collapse Tables for Easy Storage



17-Gauge Steel Frame



evenly distributed



products meet or exceed applicable ANSI/BIFMA standards





MAX Seating™
MSFT



Flip-Top
TGT



WOOD FOLDING TABLES

MAX Seating Tables™

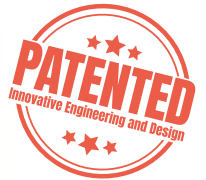

Features

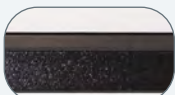

16-Gauge C-Channel Frame



2-Point Welded Leg Brace



14-Gauge 1.25" Square Leg Tubing Legs



Proprietary Leg Clips Secure Legs When Folded



Auto-Engage Locking Mechanism



High-Impact, Non-Marring Spring Steel Flower Glides



Folding/Locking Mechanisms Exceeded 7,000 Cycle Tests



Legs at Table Corners for Max Seating™



Nylon Corners With Standoff for Scratch-Free Stackability



14-Gauge Stability Boost Leg Brackets

Compact Wood Folding Bench

Same Heavy Duty structure as MAX Seating Tables



Tabletops

Custom tabletop core and surfaces available



Particleboard with 3mm PVC Edge
 .75" Core | HPL Surface
 3mm Hot-Melt PVC Edge (PB EB)



MDF with Protect Edge
 .75" Core | HPL Surface
 Protect Edge (MD PE)



Plywood with 3mm PVC Edge
 .75" Core | HPL Surface
 3mm Hot-Melt PVC Edge (PW EB)

PAGE 177 | Laminate and Edge Design Options

Model Number Configuration

Prefix
MSFB 1572 PW EB GY
 Core Edge
 Width/Length Laminate Color

Sizes

- 15"x60"
- 15"x72"
- 15"x96"



Custom Size Tables:

Upcharge and extended lead time apply

We can build any length tabletop on the smaller size frame (up to 108" long). We will install it onto the closest smaller size frame (60", 72", 84" & 96" Length).

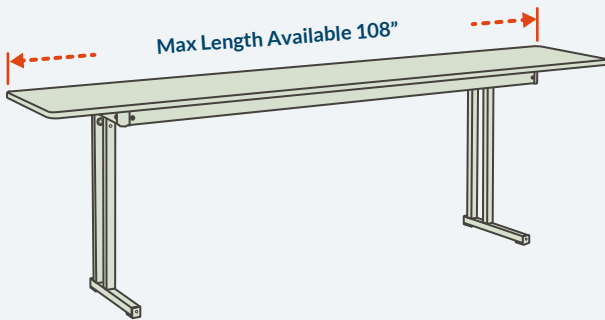

Recessed Legs:

*Available only for rectangle shape | Upcharge and extended lead time apply

Table legs can be recessed to your ideal placement to help maximize seating space. When recessing legs, only the legs for which a dimension is noted will be recessed. Any non-specified legs will be mounted at the standard placement.

To recess the right leg:

Add **R** followed by distance from the edge of the tabletop at the end of model number (i.e. R12)

To recess the left leg:

Add **L** followed by distance from the edge of the tabletop at the end of model number (i.e. L8)

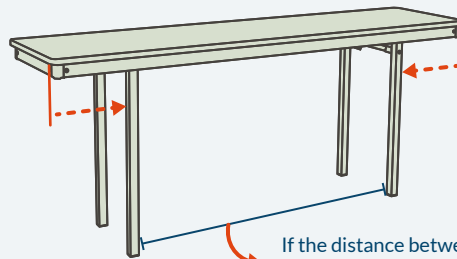

If the distance between legs is less than 58" Table Will Not Fold Flat



Model Number Configuration

Custom Length
MSFT 24108 PW EB GY

Model Number Configuration

Right Leg Recessed Distance from Edge
MSFT 2448 PW EB GY R12 L8
 Left Leg Recessed Distance from Edge



Please note:

- All testing was conducted with standard tabletop and leg configurations. Recessing legs or customizing tabletops may cause table to be susceptible to tipping.
- Please allow up to 2 inch tolerance.

WOODEN FOLDING TABLES | TGT SERIES
Flip Top Table



 **PAGE 177** | Laminate and Edge Design Options

Features



Heavy Duty 3" Locking Casters



14-Gauge Steel Frame



Auto Lock System



Tables Flip and Nest for Simple Storage

Table Core/Edge Options



1.2" MDF Core
 HPL Surface
 Protect Edge (MDPE)



1.2" Particleboard Core
 HPL Surface
 T-Mold (PBTM)

Model Number Configuration

Model Number Core Edge
TGT 2448 MD PE GY
 Width/Length Laminate Color

Model #	Seats	Table WxL	Table-Seat Height (Standard)
TGT2448	2-3	24"x48"	24"x48"
TGT2460	3-4	24"x60"	24"x60"
TGT3048	2-3	30"x48"	30"x48"
TGT3060	3-4	30"x60"	30"x60"

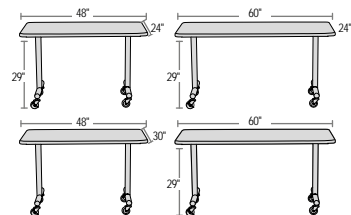



5/8
From Tech work for you in
"What"
personal again
Tablets use HW in Lab 201
Interaction of your day
data - Efficiency Time
Blended learning
Future Learning
Personalized Learning

5/8/15
From Tech work for
"What"
personal again
Tablets use HW in Lab
Interaction of your
data - Efficiency
Blended learning





STEEL TABLES

Titan
TT



Heavy Duty
HDT



Titan Table



Features



14-Gauge Legs Are Set at a 94 Degree Angle



Tamper-Free Hardware



Super-Duty Sheet-Metal Apron Design



Undertable Hat Structure for Ultimate Durability



Legs Are Fastened With a Double Bolt and Four Screw Connection



6 Millimeter Thick Foot Plate for Extreme Strength



Tables Ship With Frame Pre-Installed



Apron Is Constructed from 14-Gauge Steel

THREE HEIGHTS AVAILABLE

Frame Color



Titan Table

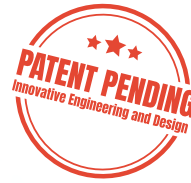

Heights



Model Number Configuration

Prefix Casters/Glides Top
TT02-2448 G 1 PBTM GY
 Width/Length Height Laminate Color (if applicable)

Table Foot Options



4" Lock Casters
 Constructed with Polyamide Plus TPU Tread
 (C)



Super-Duty Steel Glides
 Powercoated Grey Felt base rubber foot
 (G)

Size (Width/Length in inches)

2436	2442	2448	2454	2460	2472	2484	2496
3036	3042	3048	3054	3060	3072	3084	3096
3636	3642	3648	3654	3660	3672	3684	3696
4242	4248	4254	4260	4272	4284	4296	
4848	4854	4860	4872	4884	4896		

- Quick ship tables available, choose from tops B, W, C, P
- Quick ship tables available, choose from tops P and C
- Quick ship tables available with top C only

Standard lead time is 8 weeks. Quick ship lead time is 7 days.

Tabletops



Standard High Pressure Laminate
 1.2" particleboard core
 HPL Surface | T-molding (PBTM)



Supreme High Pressure Laminate
 1.2" MDF core
 HPL Surface | Protect Edge (MDPE)



Whiteboard
 1.2" Particleboard Core
 Markerboard HPL Surface | PVC Edge Banding (W)



Chem-Res
 1" Particleboard Core
 Chemical Resistant Top Edge Banding (C)



Phenolic
 .75" Solid Phenolic
 Designer Beveled Edges (P)



Trespa
 .75" Cellulose Core
 Designer Beveled Edges (T)



Butcherblock
 1.75" Solid Maple Wood
 Proprietary UV Finish (B)

See page 181 for warranty, finish options and care instructions.



products meet or exceed applicable ANSIBIFMA standards



STEEL TABLES | HDT SERIES
Heavy Duty Tables





MORE THAN
2,000
DESIGN VARIATIONS

Heavy Duty Tables Specs

Tabletops



Standard High Pressure Laminate
 .75" particleboard core
 HPL Surface | T-molding
 (H)



Supreme High Pressure Laminate
 1.2" MDF core
 HPL Surface | Protect Edge
 (S)



Whiteboard
 1.2" Particleboard Core
 Markerboard HPL Surface
 | PVC Edge Banding
 (W)



Chem-Res
 1" Particleboard Core
 Chemical Resistant Top
 Edge Banding
 (C)



Phenolic
 .75" Solid Phenolic
 Designer Beveled Edges
 (P)



Trespa
 .75" Cellulose Core
 Designer Beveled Edges
 (T)



Epoxy
 1" Solid Epoxy
 Designer Beveled Edges
 (E)



Butcherblock
 1.75" Solid Maple Wood
 Proprietary UV Finish
 (B)

See page 181 for warranty, finish options and care instructions.

PAGE 177 | Laminate and Edge Design Options

The **NPS Heavy Duty Table** is ideal for any makerspace environment. The 16-Gauge apron and 14-Gauge legs make this table virtually indestructible. Available with either fixed or adjustable height legs. Adjustable legs can be raised in 1" increments and are locked firmly in place with 2 K-9 external tooth lock washers and heavy duty tamper-free hex screws. All legs come standard with simple-adjust glides and have a caster option for easy mobility.

Play. Work. Study.

Table Sizes

Width Options
 Personal sizes
 patent pending
 18"x24", 18"x30",
 24"x24", 24"x30",
 30"x30"

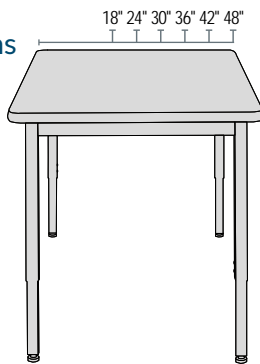

Length Options

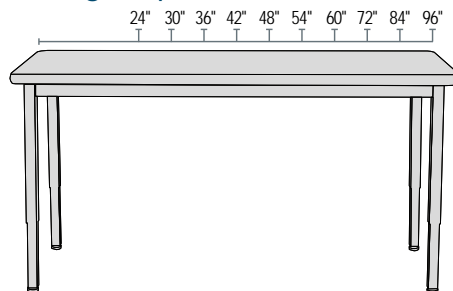

Leg Construction

Fixed Height Legs:



Adjustable Height Legs:



Standard Features

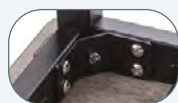

Corner Brackets Bolted Onto Frame



Dual-Side Leg Connection



Welded 12-Gauge Leg Top Plate



Adjustable Legs Adjust in 1" Increments



11-Gauge Welded Support Brackets



16-Gauge Channel Frame

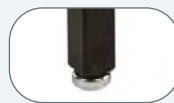

Leveling Glides Can Add up to 3/4" Height to Table



Exceeds 500lbs. Static Weight Capacity

Optional Accessories

Casters

3" Heavy-Duty Casters



- 4 Heavy Duty Swivel Locking Casters
- Increases the Table Height by 3¼"
- A Set of Gussets Is Included With Casters

Corner Gussets



- 13-Gauge Steel
- Tamper-Free Hardware
- Included With All Tables 36" & Wider, or 84" & Longer
- Recommended When Using Tables Above 30" High

Peg Boards

Available for 24" and 30" Tables



- Two 16-Gauge Industrial Grade Peg Boards Included in Each Set
- Variety Set of 50 7-Gauge Chromed Pegs Included With Each Peg Board Set
- Holes Spaced 1" Apart
- Assembled With Tamper-Free Self-Tapping Screws



Model Number Configuration

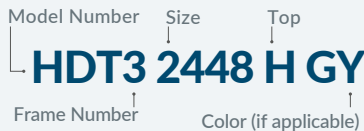

All tables wider than 30", longer than 72", or with Epoxy/Trespa tabletops will include a set of gussets

Accessories Model Number Configuration

Core Model #

CAST-3

Frame #

Model# Description

CAST-	4 heavy duty casters and gusset
PEG24-	2 Peg boards with 50 Pegs for 24"W Tables
PEG30-	2 Peg boards with 50 Pegs for 30"W Tables

(for example, "3" should be used for accessories used for table frame # HDT3)

Frame# Description

HDT3	Heavy Duty Table, Height Adjustable, Textured Black
HDT7	Heavy Duty Table, Fixed Height Legs, Textured Black
HDT8	Heavy Duty Table, Height Adjustable, Soft Grey
HDT9	Heavy Duty Table, Fixed Height Legs, Soft Grey

Size (width/Length in inches)

1824	1830	1836	1842	1848	1854	1860	1872	1884	1896
2424	2430	2436	2442	2448	2454	2460	2472	2484	2496
3030	3036	3042	3048	3054	3060	3072	3084	3096	
3636	3642	3648	3654	3660	3672	3684	3696		
4242	4248	4254	4260	4272	4284	4296			
4848	4854	4860	4872	4884	4896				

- Quick ship tables available, choose from tops B, W, C, P, and H with grey nebula laminate
- Quick ship tables available, choose from tops P and C
- Quick ship tables available with top C only

Standard lead time is 8 weeks. Quick ship lead time is 7 days.

Top Description/edge

B	1.75" Solid Maple Butcherblock/UV Finish
W	1.25" Whiteboard/PVC Edge Banding
H	.75" Standard High Pressure Laminate with T-Mold
S	1.25" Supreme High Pressure Laminate with Protect Edge
C	1" Chem-Res/3mm Edge Banding
P	.75" Solid Phenolic/Beveled Edge
T	.75" Solid Trespa/Beveled Edge
E*	1" Solid Epoxy/Beveled Edge

*not compatible with casters

Frame Color Options



Textured Black

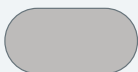

Soft Grey







SCIENCE

Science Tables
SLT1, SLT2, SLT3,
SLT7, SLT8, SLT9



**Signature
Tables**
SLT4, SLT5



**Designer
Table**
SLT6



**Science
Cart**
MSC



SCIENCE TABLES | SLT SERIES

Solid Wood Tables

Top Options

SEE PAGE 176 FOR TABLETOPS GUIDE



HPL



CHEM-RES



See page 181 for custom color options

PHENOLIC



WHITE BOARD



EPOXY*



TRESPA



Features



Rubber Boots
Protect Against Spills



Legs Attach W/ Metal
on Metal Double Bolt
Assembly on 13-Gauge
Steel Corner Braces



Solid Ash Frame
And Legs



Adjustable Glides
for Accurate Floor
Leveling



Available
With Book
Compartments



Optional Heavy Duty
3" Locking Casters and
Stretchers and Braces

Model Number Configuration

Model Number Size Add-Ons

SLT1 - 2448 H BC

Top Material

Model# Description

SLT1	30" High*, Science Lab Table, Wood Frame
SLT2	36" High*, Science Lab Table, Wood Frame

Size (width/Length in inches)

2430	2448	2454	2460	2472
3030	3060	3072	4260	4272

- Lightning ship tables available, choose from tops H, C and P
 - Lightning ship tables available, choose from tops H, C, P, and W
 - Lightning ship tables available with top C only
- Standard lead time is 8 weeks.
Quick ship lead time is 7 days.

Top Description

B	Butcher Block
W	Whiteboard
H	High-Pressure Laminate
C	Chem-Res
P	Phenolic
E*	Epoxy
T	Trespa

*not compatible with caster

Add-on Description

B	Add Book Boxes
C	Add Casters* & Stretchers



*Additional 3.5" Height when ordered with Casters
All tables wider than 30", longer than 72", or with Epoxy/Trespa tabletops will include stretchers and braces



CATALOG | 2023



products meet
or exceed applicable
ANSI/BIFMA standards

Top Options

SEE PAGE 176 FOR TABLETOPS GUIDE



HPL



CHEM-RES



See page 181 for custom color options

PHENOLIC



EPOXY*



TRESPA



Features



Corner Brackets Bolted Onto Frame



Welded 12-Gauge Leg Top Plate



11-Gauge Welded Support Brackets



Leveling Glides Can Add up to 3/4" Height to Table

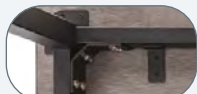

Dual-Side Leg Connection



Adjustable Legs Adjust in 1" Increments



16-Gauge Channel Frame



Optional Heavy-Duty 3" Casters and Gussets Available



Color Options



Black

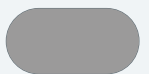

Soft Grey

Model Number Configuration

Model Number Size Top Material

SLT3 - 2448 H

Size (width/Length in inches)

2430 2448 2454 2460 2472

3030 3060 3072 4260 4272

- Lightning ship tables available, choose from tops H, C and P
- Lightning ship tables available with top C only

Standard lead time is 8 weeks.
Quick ship lead time is 7 days.

Top Description

H	High-Pressure Laminate
C	Chem-Res
P	Phenolic
E*	Epoxy
T	Trespa

*not compatible with caster

Model# Description

SLT3	Height adjustable steel table, black
SLT7	Fixed Height steel table, black
SLT8	Height adjustable steel table, soft grey
SLT9	Fixed Height steel table, soft grey

Caster/Gusset Model

Model Number Frame Number (of table that it will be used with)

CAST-3



Without Casters



With Casters



products meet or exceed applicable ANSI/BIFMA standards

All tables wider than 30", longer than 72", or with Epoxy/Trespa tabletops will include a set of gussets

Signature Tables

Top Options

SEE PAGE 176 FOR TABLETOPS GUIDE



HPL



CHEM-RES



See page 181 for custom color options

PHENOLIC



Features



Available With Book Compartments



Aprons Made of Solid Ash



Aprons Reinforced With 13" Gauge Steel Corner Brackets



Legs Adjust in 3/4" Increments from 27"-42"H With Included Spacer



11-Gauge Leg-Bases Fastened to Tabletop With 6 Heavy-Duty Screws



Legs Come Standard With Simple-Adjust Glides for Accurate Floor Leveling



Optional Casters Available for Lightweight Use

Model Number Configuration

Model Number Size Top Material Add-Ons

SLT4 - 2448 H BC

Model# Description

SLT4	Black Legs, Signature table w/ black legs
SLT5	Oak Legs, Signature table w/ oak legs

Size (width/Length in inches)

2430	2448	2454	2460	2472
	3030	3060		

Lightning ship tables available, choose from tops H, C, and P

Standard lead time is 8 weeks.
Quick ship lead time is 7 days.

Leg Options

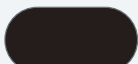

Black



Oak

Top Description

H	High-Pressure Laminate
C	Chem-Res
P	Phenolic

Add-on Description

B	Add Book Boxes
C	Add Casters



products meet or exceed applicable ANSI/BIFMA standards

Top Options

SEE PAGE 176 FOR TABLETOPS GUIDE



HPL



CHEM-RES



See page 181 for custom color options

PHENOLIC



BUTCHERBLOCK



WHITEBOARD



Features



1.2" Thick Reinforcement Board Under Tabletops for Added Strength



Legs Adjust in 3/4" Increments from 27"-42"H With Included Spacer



11-Gauge Leg-Bases Fastened to Tabletop With 6 Heavy-Duty Screws



Legs Come Standard With Simple-Adjust Glides for Accurate Floor Leveling



Optional Casters Available for Lightweight Use

Model Number Configuration

Model Number Size Top Material Add-Ons
SLT6 - 2448 H C

Size (width/Length in inches)

2430 2448 2454 2460 2472
3030 3060

● Lightning ship tables available, choose from tops H, C, and P

Standard lead time is 8 weeks.
Quick ship lead time is 7 days.

Top Description

W Whiteboard
B Butcherblock
H High-Pressure Laminate
C Chem-Res
P Phenolic

Add-on Description

C Add Casters



products meet or exceed applicable ANSI/BIFMA standards

MOBILE SCIENCE CARTS



SINK OPTION
for Most Models



BUILT-IN POWERSTRIP
on Most Models



**HEAVY-DUTY
CONSTRUCTION**

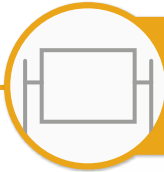

WHITEBOARD/MIRROR
for Most Models

INTRODUCING

A FULL LINE OF FULLY ASSEMBLED*
mobile science carts.



**BUILT-IN
MAGNETIC GANGING**

**CUSTOM TOPS
AVAILABLE**



*Caster Assembly Required

Mobile Science Cart

with Shelving



Model Numbers
 Standard
MSC01
 Sink
MSC01S
 Whiteboard/Mirror
MSC01W
 Sink & Whiteboard/Mirror
MSC01WS

Features

- 2 Doors With 270° Wrap-Around Hinges
- Plywood Core Cabinet And Shelves
- Two Adjustable Height Shelves
- Door Lock

28"W x 48"L x 36.25"H

Tabletop

Chem-Res
1" Thick

Color

Oak Veneer

Storage Cart
Ships Unassembled

Model Number
MSC 2436

24"W x 36"L x 36"H

Features

- One Adjustable Height Shelf
- 1 1/4" Thick High Pressure Laminated Surface, Compliant With NEMA Standard Testing



Mobile Science Cart

with Inner Drawers and Shelf

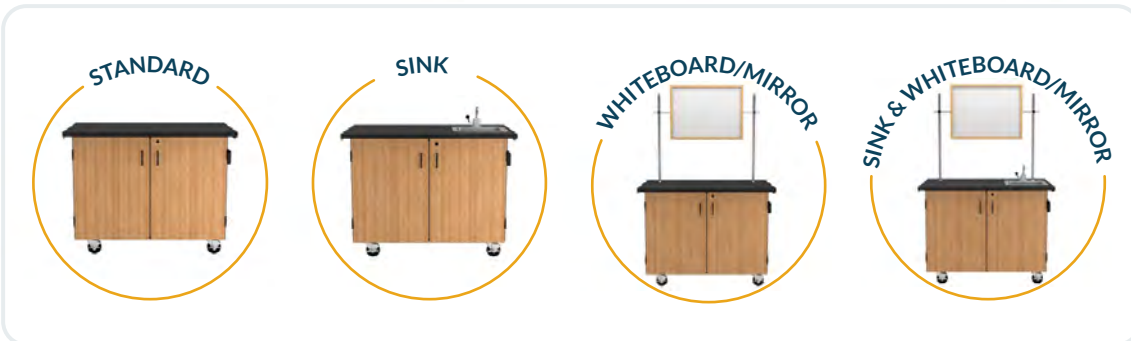

Model Numbers

Standard

MSC02

Sink

MSC02S

Whiteboard/Mirror

MSC02W

Sink & Whiteboard/Mirror

MSC02WS

Features



2 Doors With 270°
Wrap-Around Hinges



Plywood Core Cabinet
And Shelves

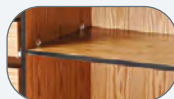

Adjustable
Height Shelf



Four Concealed
Drawers

28"W x 48"L x 36.25"H

Tabletop



Chem-Res
1" Thick

Color



Oak Veneer



Mobile Science Cart

with External Drawers and Pegboard

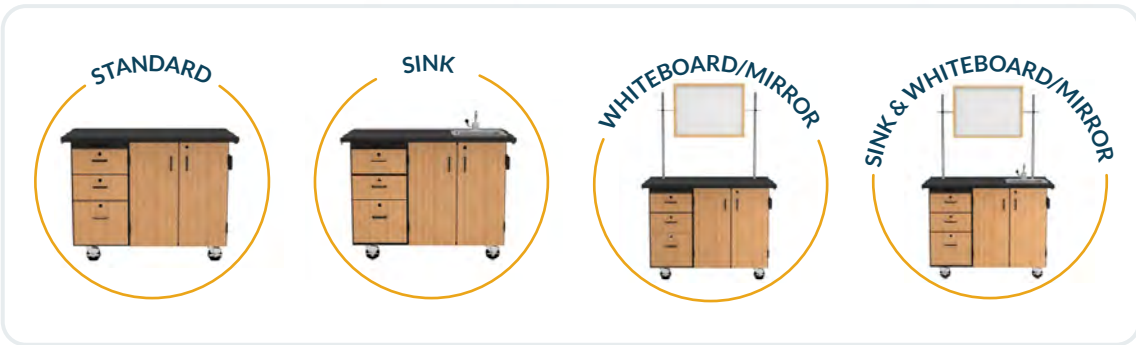

Model Numbers

- Standard
MSC03
- Sink
MSC03S
- Whiteboard/Mirror
MSC03W
- Sink & Whiteboard/Mirror
MSC03WS

Features



2 Doors With 270° Wrap-Around Hinges



Plywood Core Cabinet And Shelves



Pullout Pegboard With 50 Assorted Pegs



Three External Drawers and a Pullout Shelf on Sliders

28"W x 48"L x 36.25"H

Tabletop



Chem-Res 1" Thick

Color



Oak Veneer



Mobile Science Cart with Tote Trays



SHIPS WITH **24**
TOTE TRAYS



28"W x 48"L x 36.25"H

Model Number
MSC04

Features



2 Doors With 270°
 Wrap-Around Hinges



Plywood Core
 Cabinet



Removable
 Storage Trays



Storage Trays Nest
 When Not in Use

Tabletop



Chem-Res
 1" Thick

Color



Oak Veneer

Mobile Science Cart with Microscope Dividers



HOLDS UP TO **24**
MICROSCOPES



28"W x 48"L x 41.5"H

Model Number
MSC05

Features



Four Doors With 270°
 Wrap-Around Hinges

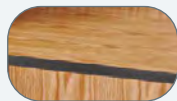

Plywood Core
 Cabinet and Shelf

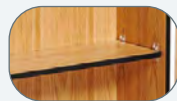

Adjustable
 Height Shelf



Removable
 Microscope Dividers

Tabletop



Chem-Res
 1" Thick

Color



Oak Veneer





WORKSTATIONS

**Sit Stand
Desks**
EDTC, SSD



Workstations
Teacher's EduPod
Teacher's WorkPod



WORKSTATIONS | EDTC SERIES
Sit Stand Students Desk



Features



Strong Powder-Coated Steel Frame



2 1/2" Two-Tone Double-Wheel Hooded Casters



Pneumatic Adjusting System

Model Number
EDTC

Color

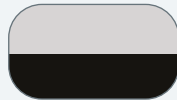

Speckled Grey Surface
 Black Steel Frame

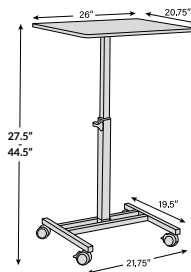

Description	Dimensions
Top Shelf Dimensions	26" L x 20.75" D
Height Adjustable	27.75" - 44.5" 30"
Leg Dimensions	21.75" L x 19.5" D
Unit Weight	35 lbs.

WORKSTATIONS | SSD SERIES
Sit Stand Students Desk Pro



Features



Strong Powder-Coated Steel Frame



2 1/2" Two-Tone Double-Wheel Hooded Casters



One Button Click Pneumatic Adjusting System



Book-Bag Holder



Plastic Surface With Embedded Tablet Groove



Built-in Modesty Panel

Colors



Charcoal Grey Surface
 Soft Grey Frame



Model Number
SSDG-20



products meet or exceed applicable ANSIBIFMA standards



Description

Surface Dimensions
 Height Adjustable
 Distance Between Legs

Dimensions

23.5" W x 19.5" D
 28.5" - 41.75"
 21.5"

WORKSTATIONS | EDPD SERIES
Edupod Teacher's Desk & Lectern



Features



Beautiful Blow-Molded Table Top



3 Shelves, 2 Adjustable for Customizability

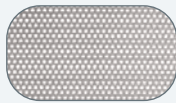

Built-in Perforated Modesty Panel



Locking Storage Cabinet for Security



Wire Management Grommet for Technology Equipment



6 Hooded Twin-Wheel, Two-Inch Casters, 3 Lock for Stability

Colors

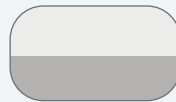

Speckled Grey Tabletop
 Grey Hammer Tone Cabinet and Frame

Model Number
EDPD

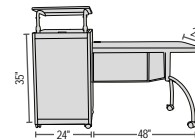

Description

Dimensions

68" L x 24" W	Overall Dimensions
48" L x 24" W	Desk Dimensions
2-inch	Desk Thickness
24" L x 20" W x 35" H	Cabinet Dimensions (including casters)
24" L x 20" W	Lectern Desk
3/4-inch	Lectern Thickness
19" L x 22" W	Cabinet Shelves Dimensions
115 lbs.	Unit Weight
85 lbs.	Lectern Portion Weight



Colors



Charcoal Slate and Black

Features

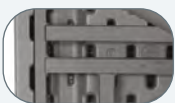

Double Frame for Added Support



Desk Can Be Hooked on to Either Side of the Lectern

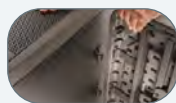

Unhook the Desk from the Lectern to Use Separately



Built-in Attractive Mesh Front Provides Venting to Prevent Overheating



Contemporary Frame and Legs



Adjustable Height Surface with Metal Bookstop

Model# Description

TWPD	Teacher's WorkPod Desk
TWPL	Teacher's WorkPod Lectern
TWP	Teacher's WorkPod Desk & Lectern Kit

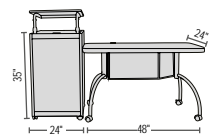

Description

Dimensions

68" L x 24" W	Overall Dimensions
48" L x 24" W	Desk Dimensions
2-inch	Desk Thickness
24" L x 20" W x 35" H	Cabinet Dimensions (including casters)
24" L x 20" W	Lectern Desk
3/4-inch	Lectern Thickness
19" L x 22" W	Cabinet Shelves Dimensions
115 lbs.	Unit Weight
85 lbs.	Lectern Portion Weight







BE KIND
DON'T
LET ANYONE
TALK YOU
OUT OF
TRYING
IT'S
A GOOD
DAY
TO HAVE A
GOOD DAY

MOBILE TABLES

Mobile Table

MT, MTFB,
MTS, MTSB



Easy Fold

MTSSF



Convertible Bench

CBG



Booth Seating

TG, CSB



Our tables come in

Rectangle



Square



Hexagon



Octagon



all shapes and sizes

Round



Oval



Elliptical



>>>>>>

SEE NEXT PAGE FOR

**DESIGNER
SHAPES**

>>>>>>

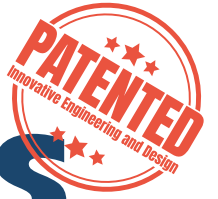

Designer Shapes

Swerve Table

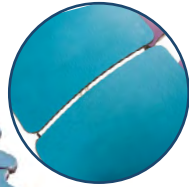

Bedrock Table



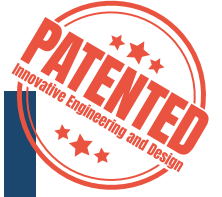

ErgoMax Stool

14" Wide



*An Ergonomically
Designed Mobile
Table Stool for
Maximum Comfort.*



Table & Bench Core Options



3/4" MDF (MD)



3/4" Particleboard (PB)



3/4" Plywood (PW)

Frame Color Options



Chrome (CR)



Black Powder Coating (PC)

Table/Seat Heights*

25"/13"
code: 25

27"/15"
code: 27

29"/17"
standard‡

32"/20"
code: 32

*For non-standard heights add code to end of model number
‡Standard MTS1216 is 27"/15"



Mobile Table Features Stool, Bench, Shape, and Combo Units



Casters Lift off Floor to Prevent Table from Moving When Opened



Tamper-Free, Non-Marring, Nylon Steel-Insert Glides and Tube Closures



Protect Edge Option Prevents Food from Being Trapped Between the Laminate and Edge



Self-Leveling Automatic Down Lock Ensures Engagement Every Time Table Is Fully Opened



Locks Table Partially Open for Easy Floor Cleaning



No Need to Reach in! Storage Latch Release Handles on Both Sides of Table to Unlock. Locks Automatically When Folded



4" Double Ball Bearing Non-Marring Heavy-Duty Casters With 275 Lb. Weight Capacity Ea



"EasyLift" Torsion Bar System. One Person Can Easily Lift and Fold Table for Convenient Storage



14-Gauge Steel Framing

Bench Features



Prevent Tripping During Entry With Our Exclusive Curved Frame Design



3/4" Thick Benches Reinforced With 16-Gauge Aprons

Stool Features



High Impact Stools Reinforced With Embedded Steel Washers



Hex-Head Serrated Flange Bolts & Serrated Flange Nylon Insert Nuts Provides Stronger and Simpler Assembly

Easy Fold Features



One-Piece Top Eliminates the Gap in the Middle of Surface



4" Double Ball Bearing Non-Marring Heavy-Duty Casters With 275 Lb. Weight Capacity Ea



Casters Lift off Floor to Prevent Table from Moving When Opened



Gas Spring Rated to 100,000 Cycles Balances Open-Fold Operation - Simple for One Person Operation



Automatically Locks Open With Two Points of Manual Release to Fold

Convertible Bench Features



Create One Large Table By Combining Single Bench Units, Using the Built-in Ganging Devices



Non-Marring Reinforced Nylon Glides With Steel Inserts Installed Over Leg Uprights.



"Pinch-Proof" Feature: Bench Does Not Touch the Top When Folding



Under Table Hat Supports 1000 Lbs. Weight Capacity (CBG96 Only)



Easy Lock 3" Double Ball-Bearing Heavy-Duty Casters





>>>>>>

ADD YOUR

LOGO!

JUST SEND IN AN .AI FILE

>>>>>>



Custom Graphic Laminates are available on Tabletops with Particleboard and MDF core only.



Shape Tables

*Mobile tables that
shape up to your unique
seating needs.*



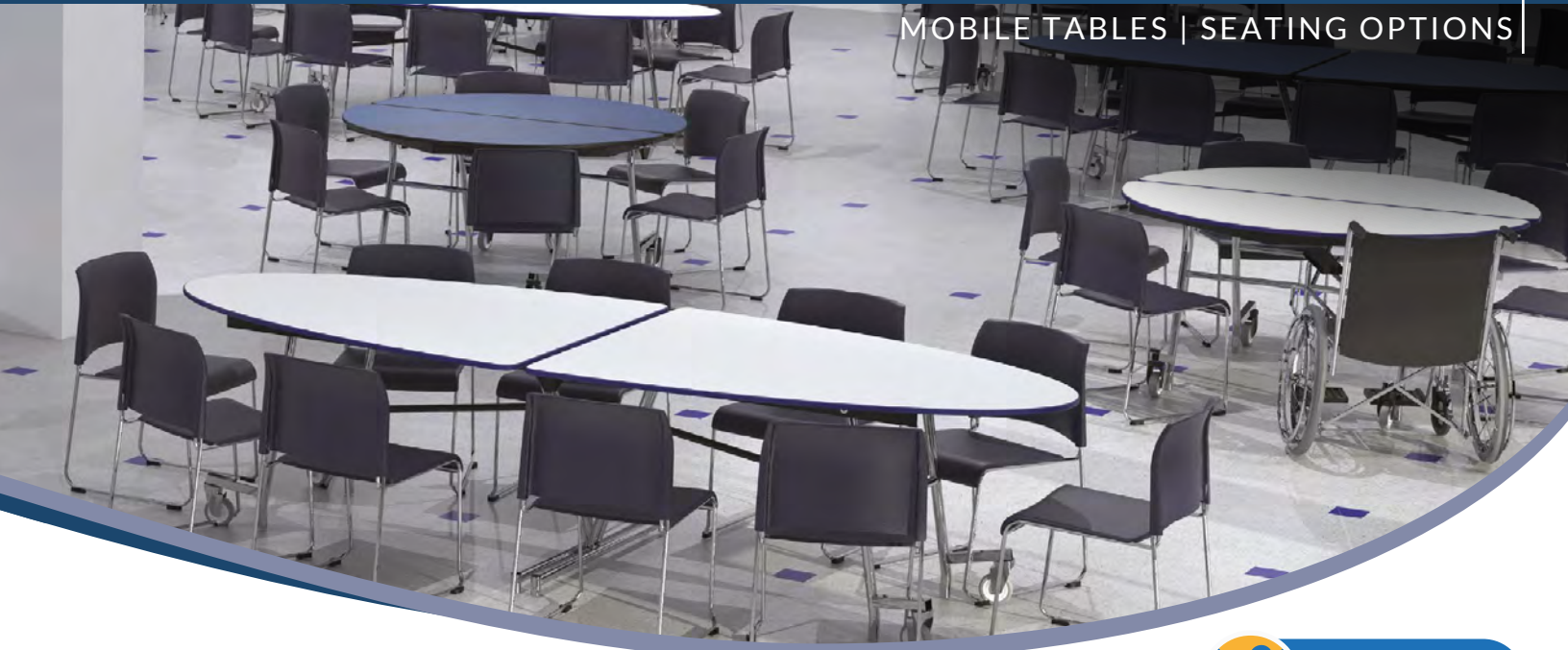

See **Page 90** for Product Features



Shapes

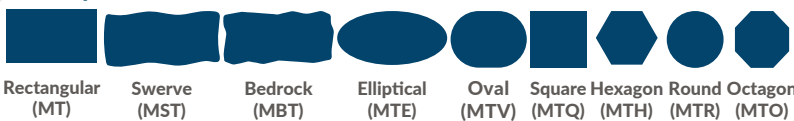

7 DAY QUICK SHIP

MT12-MDPEPCGY
(12' Rectangle, MDF/ProtectEdge, Textured Black Frame, Grey Nebula Top)
MT60R-MDPEPCGY
(60" Round, MDF/ProtectEdge, Textured Black Frame, Grey Nebula Top)

Model Number Configuration

Model # Core Edge Frame Laminate Color Top

MTE10-PW PE CR CH

Add custom height to the end of model number

ADA Configurations

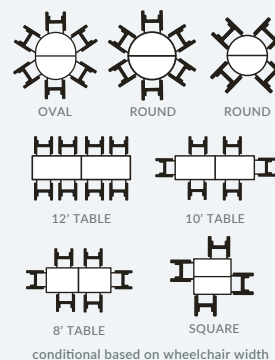

Model #	Shape	Table WxL	Folded Dimensions	Table Height (Standard)	Table Height (Custom)
MT8	Rectangular	30"x97"	30"x30"x60"	29"	
MT10	Rectangular	30"x121"	31"x30"x68"	29"	
MT12	Rectangular	30"x145"	32"x30"x81½"	29"	
MST8	Swerve	30"x97"	30"x30"x60"	29"	25"
MST10	Swerve	30"x121"	31"x30"x68"	29"	27"
MST12	Swerve	30"x145"	32"x30"x81½"	29"	32"
MBT8	Bedrock	30"x97"	30"x30"x60"	29"	
MBT10	Bedrock	30"x121"	31"x30"x68"	29"	
MBT12	Bedrock	30"x145"	32"x30"x81½"	29"	
MTE10	Elliptical	44½"x121½"	31¼"x 44½"x 67¼"	29"	
MT72V	Oval	60"x72"	19"x60"x45¼"	29"	
MT48Q	Square	48"x48"	19"x48"x39¼"	29"	25"
MT60Q	Square	60"x60"	19"x60"x42¼"	29"	27"
MT48H	Hexagon	48"x48"	19"x48"x39¼"	29"	32"
MT48R	Round	48"x48"	19"x48"x39¼"	29"	42"
MT60R	Round	60"x60"	19"x60"x42¼"	29"	
MT72R	Round	72"x72"	19"x72"x45¼"	29"	
MT60O	Octagon	60"x60"	19"x62½"x42¼"	29"	

Bench Tables

Better together! Bench tables make group seating simple.





See **Page 90** for Product Features



7 DAY QUICK SHIP

MTFB12-MDPEPCGGY
 (12' Rectangle, MDF/ProtectEdge, Textured Black Frame, Grey Nebula Top & Bench)
MTR60B-MDPEPCGGY
 (60" Round, MDF/ProtectEdge, Textured Black Frame, Grey Nebula Top & Bench)

Shapes



Model Number Configuration

Model # Core Edge Frame Tabletop Laminate
MTFB12-PW PE CR CH GY
 Add custom height and/or ADA code to the end of model number Bench Laminate

Model #	Shape	Seats	Table WxL	Folded Dimensions	Table Height (Standard)	Table Height (Custom)
MTFB8	Rectangular	8-12	30"x97"	56"x34½"x59¾"	29"-17"	
MTFB10	Rectangular	10-14	30"x121"	56"x35"x68½"	29"-17"	
MTFB12	Rectangular	12-16	30"x145"	56"x35½"x81"	29"-17"	
MSTB8	Swerve	8-12	30"x97"	56"x34½"x59¾"	29"-17"	
MSTB10	Swerve	10-14	30"x121"	56"x35"x68½"	29"-17"	25"-13"
MSTB12	Swerve	12-16	30"x145"	56"x35½"x81"	29"-17"	27"-15"
MBTB8	Bedrock	8-10	30"x97"	56"x34½"x59¾"	29"-17"	32"-20"
MBTB10	Bedrock	10-12	30"x121"	56"x35"x68½"	29"-17"	
MBTB12	Bedrock	12-16	30"x145"	56"x35½"x81"	29"-17"	
MTEB	Elliptical	10-12	45"x121"	72"x35½"x73½"	29"-17"	
MTR60B	Round	8	60"x60"	34"x86"x54½"	29"-17"	
MTO60B	Octagon	8	60"x60"	34"x86"x54½"	29"-17"	

ADA Configurations

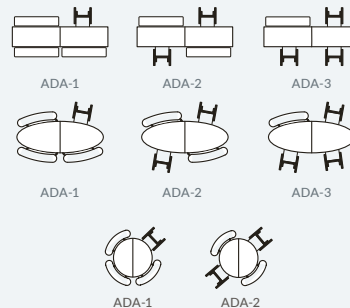

conditional based on wheelchair width

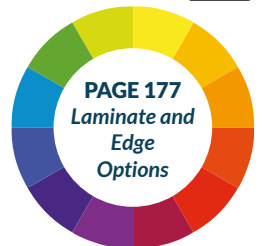



Stool Tables

*Roll in, roll out, flip,
and store. Pairs well
with any seating!*





See Page 90 for Product Features



Shapes



7 DAY QUICK SHIP

MTS12-MDPEPCGYxx
 (12' Rectangle, MDF/ProtectEdge, Textured Black Frame, Grey Nebula Top)
 MTR60S-MDPEPCGYxx
 (60" Round, MDF/ProtectEdge, Textured Black Frame, Grey Nebula Top)

Model Number Configuration

Model # Core Edge Frame Laminate ErgoMax Stool

MTS12-PW PE CR CH 04 E

Add custom height and/or ADA code to the end of model number Stool Color

Model #	Shape	Seats	Table WxL	Folded Dimensions	Table Height (Standard)	Table Height (Custom)
MTS8	Rectangular	8	30"x97"	30"x59"x57"	29"-17"	25"-13"
MTS10	Rectangular	12	30"x121"	59"x36"x73½"	29"-17"	27"-15"
MTS12	Rectangular	12	30"x145"	59"x39"x79¾"	29"-17"	
MTS1216	Rectangular	16	30"x145"	59"x35"x81½"	27"-15"	25"-13"
MSTS8	Swerve	8	30"x97"	56"x34½"x59¾"	29"-17"	25"-13"
MSTS10	Swerve	10	30"x121"	56"x35"x68½"	29"-17"	27"-15"
MSTS12	Swerve	12	30"x145"	56"x35½"x81"	29"-17"	32"-20"
MSTS1216	Swerve	16	30"x145"	59"x35"x81½"	29"-17"	25"-13"
MBTS8	Bedrock	8	30"x97"	32"x59"x57"	27"-15"	25"-13"
MBTS10	Bedrock	12	30"x121"	59"x36"x73½"	29"-17"	27"-15"
MBTS12	Bedrock	12	30"x145"	59"x39"x79¾"	29"-17"	32"-20"
MBTS1216	Bedrock	16	30"x145"	59"x35"x81½"	27"-15"	25"-13"
MTR60S	Round	8	60"x60"	38"x81"x54½"	29"-17"	25"-13"
MTO60S	Octagon	8	60"x60"	38"x81"x54½"	29"-17"	32"-20"
MTES	Elliptical	12	45"x121"	59"x35"x81½"	29"-17"	25"-13"
						27"-15"

ADA Configurations

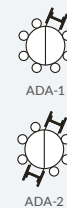
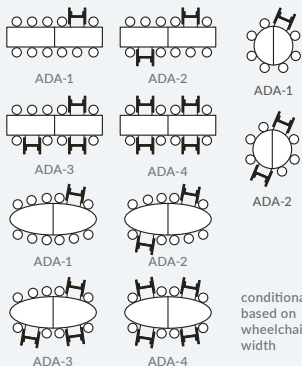

PAGE 177
 Laminate, Edge,
 and Stool
 Options



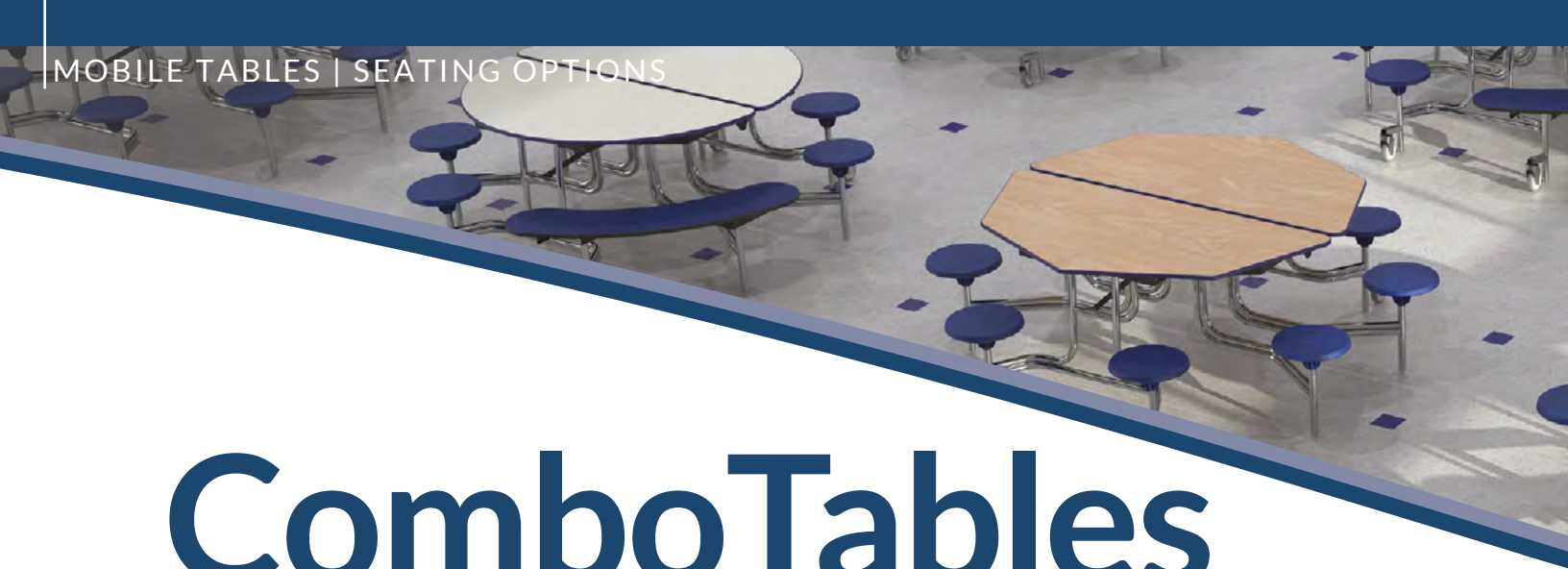

Combo Tables

The best of both worlds - bench or stool, sit together how you'd like!



Easyfold Units

*Roll in, roll out, flip,
and store. Pairs well
with any seating!*





 See **Page 90** for Product Features



PAGE 177
Laminate, Edge, and Stool Options

Shapes



Model #	Shape	Table WxL	Folded Dimensions	Table Height (Standard)	Table Height (Custom)
MTSSF-60V	Oval	60"x72"	72"x20"x72"	29"	
MTSSF--48Q	Square	48"x48"	48"x20"x62"	29"	
MTSSF-60Q	Square	60"x60"	60"x20"x72"	29"	25"
MTSSF-48R	Round	48"x48"	48"x20"x62"	29"	27"
MTSSF-60R	Round	60"x60"	60"x20"x72"	29"	32"
MTSSF-60O	Octagon	60"x60"	60"x20"x72"	29"	42"
MTSSF-48H	Hexagon	48"x48"	48"x20"x65"	29"	

 **7 DAY QUICK SHIP**

MTSSF-60R-MDPEPCGY
(Round 60"x60", MDF Core, Black Protect Edge, Grey Nebula Top)

Model Number Configuration

Model # Core Edge Frame Laminate Color Top

MTSSF-48Q-PW PE CR CH

Add custom height to the end of model number

Convertible Bench Units

*Adaptable for your
cafeteria, auditorium
and testing center!*





Open



Flip



Gang

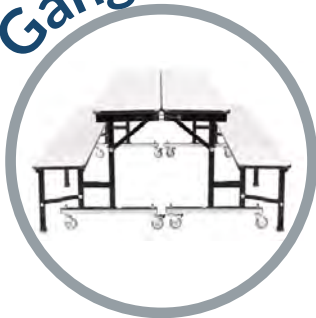

See **Page 90** for Product Features

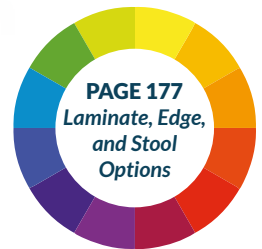

7 DAY QUICK SHIP

CBG96-MDPEPCGY (96"L, MDF Core, Black Protect Edge, Grey Nebula Back and Bench)



Model #	Seats	Table WxL	Folded Dimensions	Table Height (Standard)	Table Height (Custom)
CBG72	3-4	29"x72"	72"x12"x34"	29"-17"	25"-13"
CBG84	4-5	29"x84"	84"x12"x34"	29"-17"	27"-15"
CBG96	4-6	29"x96"	5696"x12"x34"	29"-17"	32"-20"

Model Number Configuration

Model # Core Edge Frame Back Laminate

CBG96-PW PE PC CH GY

Bench Laminate



Booth Seating





*Transforming cafeterias into cafes.
Roll and swivel into booth seating.*

ToGo Specs



BOOTH SEATING

The ToGo Benches Feature Fixed High Backs With a Slight 12-Degree Pitch Providing the Perfect Contour for Comfortable Seating.



MOBILE

Built With 14-Gauge Steel, 2" Tube Legs, and Double Ball-Bearing Non-Marring 3" Casters, the ToGo Provides the Ultimate in Strength and Mobility.



COLLABORATIVE

Today's Cafeterias Have Become Multi-Purpose Spaces Which Require Furniture That Is Mobile and Multi-Functional. NPS's ToGo Booth System Is Ideal for Such An Environment.



SIMPLE STORAGE

The ToGo Bench and Table Top Flip up and Nest for Optimal Storage. Both Are Offered in 48" or 60" Widths and 24" or 30" Depths Providing Comfortable Seating for All Sizes.



LATCH



HEAVY-DUTY 3" CASTERS



GRIP-RITE GLIDE

EASE OF USE

It's Simple to Reconfigure for Multi-Purpose Use. With Its Heavy-Duty 3" Casters the ToGo Booth Is Easy to Move. Rubber Grip-Tight Glides Automatically Engage With the Floor When Opened Along With Locking Casters to Keep Your Seating Arrangement Nicely in Place. Tables Open and Lock Automatically and Are Easily Released With the Pull of a Handle.

19" High Back 15" Wide Seat

Compared to standard 15"x12" Convertible Bench



Table Core/Edge Options



1" MDF core
HPL Surface | Protect Edge (MDPE)



1" Particleboard core
HPL Surface | T-molding (PBTM)

Model #	Seats	Open Footprint	Folded Footprint	Weight
TGT2448	2-3	24"W x 48"L x 29"H	21.25"W x 48"L x 39.50"H	58 lbs.
TGT2460	3-4	24"W x 60"L x 29"H	21.25"W x 60"L x 39.50"H	64 lbs.
TGT3048	2-3	30"W x 48"L x 29"H	21.25"W x 48"L x 39.50"H	68 lbs.
TGT3060	3-4	30"W x 60"L x 29"H	21.25"W x 60"L x 39.50"H	76 lbs.

Model Number Configuration

Model # Core Edge Laminate
TGT2448-MD PE RE



7 DAY
QUICK SHIP

TGT2460MDPEGY
(24"x60", MDF Core,
Black Protect Edge, Grey Nebula)



ToGo Table

Cluster Swivel Booth



Features



Flex Back Tested by SGS Labs to Resist 425 Lbs of Force



Unique Design for Ultimate Seating Comfort



13-Gauge Heavy-Duty Steel Frame



18-1/2" Space from Tabletop to Seat Back



Seats Are Mounted on An Industrial Grade Swivel Base



T-Shaped Legs for Extreme Stability







Undertable 11-Gauge Framing System



Tamper Free Hardware

Colors

SEAT			FRAME
			
Black (10)	Navy (04)	Charcoal (20)	Soft Grey

Model Number Configuration

Prefix	Edge	Laminate (HPL tops)	
CSBG2448		PBTM	xx 10
			Seat Color

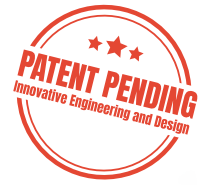

Featuring

LÜvra
 FLEX

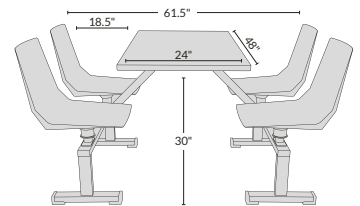
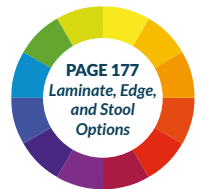

Tabletops Tabletop Dimensions are 24" x 48"



1.2" particleboard core
 HPL Surface
 T-molding
 (PBTM)



1.2" MDF core
 HPL Surface
 Protect Edge
 (MDPE)



1.2" Particleboard Core
 Whiteboard HPL Surface
 PVC Edge Banding
 (WB)



1.75" Solid Maple Wood
 Butcherblock
 Proprietary UV Finish
 (BB)

See page 181 for warranty, finish options and care instructions.



products meet or exceed applicable ANSI/BIFMA standards

ADVANTAGES & BENEFITS for NPS Mobile Tables pages 84-103

Frame Design | Table Top | Seat

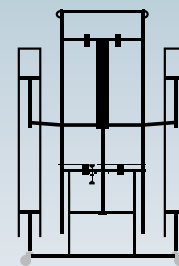

Sophistication made Simple with Safety in mind.

NPS Mobile Tables are sophisticated in design yet simple to operate. Offering enhanced safety features giving you complete peace of mind.

Frame Design *Intelligent steel understructure design supports table tops and seating providing ease of operation and maintenance.*

Table Top Apron Support

- Each top is supported by 2" deep, 14-gauge steel aprons capped at the ends with riveted plastic protectors.
- Aprons and brackets are fastened to wood with custom designed tamper-resistant screws with superior holding power while still easily serviceable if the need arises.
- Tops are supported between the leg top tubes and wood with spacers.

Leg Assembly



- Structural leg components are comprised of 1 1/4" diameter, 14-gauge steel tubing.
- Legs and stool columns are constructed of 1 1/4" diameter, 14-gauge steel tubing and braced horizontally to the stool support column on the opposite side of the table to resist bending.

Lock Rod



- Heavy duty 7/16" diameter lock rod is chrome plated to resist wear.
- Tamper resistant lock nuts on all down lock assemblies with a self-adjusting hinge lock ensure that the down lock engages every time.

Storage Lock

- Heavy duty storage lock is comprised of a 1 1/4" square tube with heavy-duty catch. Locks automatically in storage position and easily release from either side of the table when opening.

Table Top & Seats

Core



- Available in MDF, Particleboard, or Plywood.
- Tops and benches are surfaced with high pressure laminate bonded to a 3/4" thick AC grade core, sealed underneath with a poly backer for T-molded tabletops and a phenolic backer sheet for tabletops with Protect Edge. This is especially helpful when cleaning the underside of the table.

Edge (for table tops and benches)



- Available with Protect Edge or Vinyl T-Molding.
- Protect Edge is sealed with a polyurethane epoxy resin, chemically bound to the edge of the laminate, core and phenolic backing sheet.
- Vinyl T-molding is secured by staples to the top's underside approximately every 10".

Seat

Stools



- Stools are injection molded with a minimum of 25 Oz. of rubber-modified, high impact polystyrene materials measuring 13" in diameter.
- Ribs, which extend from the outer perimeter of the stool to the mounting hub in the center, are reinforced to resist failure with 12 integrally molded, tapered ribs.



- **Wobble-free** stools are mounted quickly without "wobble" with our custom designed serrated head nut and bolt. Nut also has nylon locking inserts to ensure stools stay tight.
- Power tools are recommended for safe and secure assembly.

ADVANTAGES & BENEFITS for NPS Mobile Tables pages 84-103

Frame Design | Table Top | Seat

Hardware

Table Top Screws



- Serrated head and thick threading provides superior holding power to frame with the ability to be serviced easily in the field.
- Tamper resistant.

Flower Glides and Tube Closures

- Made from glass-infused nylon and spring steel, will not break or fall out.

Casters



- 4" heavy-duty, double ball-bearing casters.
- Weight capacity of 275 lbs. per caster.
- Hard rubber, non-marring wheels.

Operation

Entrances (for bench units)

- Each bench is designed for easy entry on both ends.

Locking - Opening



- A gravity lock automatically locks the table in the open position. The lock is disengaged manually, capable of being operated from both sides of the table.

Locking - Folding



- The storage lock latch automatically locks the table in the folded storage position. The lock is disengaged manually, capable of being operated from both sides of the table and within easy reach.

Custom Torsion Bar System



- Easy opening and closing via a perfectly balanced torsion bar system.
- Each unit includes 1 to 5 torsion bars determined by table size and core material.
- Each torsion bar is at a specific angle based on weight distribution.

Safety

Lift-Off Casters



- Mobile tables incorporate the beneficial caster lift-off design in which casters lift off the floor in the open position.
- Lift-off casters do not protrude past the seats so they are not a tripping hazard.

Midway Position Lock



- Secures the unit in a partially folded position for ease of movement during floor cleaning and to prevent finger or hand pinching.

Storage Lock Latch



- Vertical adjustment ensures that the table always locks safely into the folded position.
- **UL CERTIFIED:** Tested for 7,000 open/close cycles exceeding the UL testing standard of 6,000 cycles.
- **SAFETY POSITION:** Folds in teepee position to prevent tipping.

CAFÉ



Café Chair

Café Barstool



See Page 147 for
Dolly Specs
Compatible
with **DOLLY**
DY81, DY-9000

2 DAY
LIGHTNING SHIP



See Page 147 for
Dolly Specs
Compatible
with **DOLLY**
DY81

Model Number Configuration



Model	Width	Depth	Back Height	Seat Height	Back Height
Chair	21 ½"	22 ¼"	33 ⅞"	18"	N/A
Bar Stool	21 ½"	22 ¼"	46 ½"	30"	13 ½"



products meet or exceed applicable ANSI/BIFMA standards

Features



Heavy-Duty Bumpers for Safe and Secure Stackability



Modern Handle for Easy Movement and Storage



4 Fully Welded 12-Gauge Under-Seat Support Brackets



½" Thick 8-Layer Bent Plywood Seat With HPL Finish

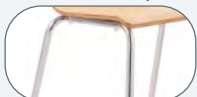

Legs Designed for Easy Stackability

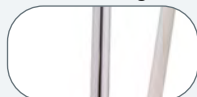

7/8" 16-Gauge Chromed Steel Tubing



Designer Contoured Waterfall Edge



Durable Non-Marring Polypropylene Glides

Colors



Espresso (21)



Natural (22)

Barstool

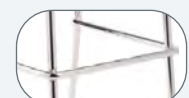

Heavy-Duty Welded Footring for Added Comfort and Stability

CAFÉ | CT SERIES
Fixed Height Tables



Features



Industrial Grade
8-Gauge Steel
Bases



Pole Connects to Base
With Heavy-Duty Bolt
and Thread Locker



Poles Have a 3"
Diameter and a Fully
Welded Base Plate



Leveling Glides
Pre-Installed to
Bases



Poles Feature a Fully
Welded Tabletop
Support Plate



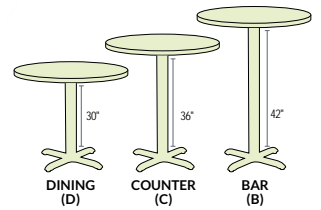

THREE HEIGHTS AVAILABLE

Tabletops



1.2" Particleboard core
HPL Surface
T-molding
(PBTM)



1.2" MDF core
HPL Surface
Protect Edge
(MDPE)



1.2" Particleboard core
Whiteboard Surface
PVC Edge Banding
(WB)



Quick ship options available

Frame Colors



Black
(no Code)



Soft Grey
(G)

Base Style



T Base
(T)



X Base
(X)



Round Base
(R)

Model Number Configuration

Prefix Shape Size Height Tabletop
CTG 2 3042 T D PBTM xx
 Color (if Grey) Base Style Laminate (HPL Tops)

Shapes



Round
(1)



Rectangle
(2)



Square
(3)



Racetrack
(4)



Curve
(5)

Rectangle & Racetrack Sizes (width/Length in inches)

2430	2436	2442	2448	2454	2460	2472	2484	2496
3036	3042	3048	3054	3060	3072	3084	3096	

Round & Square Sizes

2424	3030	3636	4242	4848
------	------	------	------	------

Curved Sizes

60°: 2491*	108°: 2492*
------------	-------------



products meet or exceed applicable ANSIBIFMA standards

Quick ship tables available in 36" round and square, choose from Grey Nebula (GY) or Figured Mahogany (MY) laminates with Black T-mold (TM)

*Recommended with T Base

CAFÉ | PCT SERIES
Premium Plus Café Table



Features



Four Locking Heavy Duty Non-Marring Swivel Casters



Heavy-Duty 13-Gauge Steel Column



1/2" Thick Solid Steel Base



Easy Pneumatic Height Adjustment



Easy To Use Non-Pinching Handle





Tabletop Options

			
1.2" Particleboard core HPL Surface T-molding (PBTM)	1.2" MDF core HPL Surface Protect Edge (MDPE)	1.2" Particleboard core Whiteboard Surface PVC Edge Banding (WB)	1 ½" Blow Molded Top (BM)

Shapes

Round
 (1)

Square
 (3)



Quick ship options available

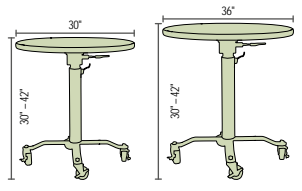

Model Number Configuration



Size (square/round in inches)

24	30	36*
----	----	------------

● Quick ship tables available in this size, choose from tops BM and PB with Grey Nebula (GY) or Figured Mahogany (MY) laminates with Black T-mold (TM)

Standard lead time is 8 weeks.
 Quick ship lead time is 7 days.

*Blowmold top only available in 36" square.



				
---	---	---	---	---

CAFÉ | CTT/CTS SERIES
Café Time



Roll In



Flip



Store



Color



Charcoal Slate
 Silver Tone Frame

Table Features



Concealed Pneumatic
 Lever Makes for Effortless
 Raising and Lowering



Casters and
 Glides Included



Tabletop Sets Into
 Vertical Position For
 Compact Storage

Chair Features



Rubber Glides To
 Protect Floors



Stacks For
 Easy Storage



Scratch Resistant,
 Attractive Chair Seats
 & Backs

Model# Description

CTT3042	Café Time Adjustable-Height Table
CTS30	Café Time Stool

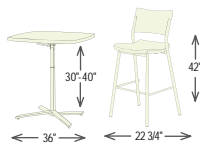





MUSIC

Melody Chair®
8210



Music Stand
82MS



Conductor
CSS, CP2, CS, CTS



Melody Chair®



Stacks
18
CHAIRS

See Page 147 for
Dolly Specs



Compatible
with **DOLLY**

DY82

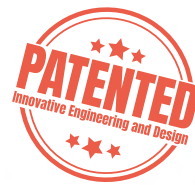

Melody Chair® Jr.

(16" SEAT HEIGHT VS. 17.5" ON THE 8210)

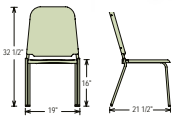

Model Number
8210-16



**TWO HEIGHTS
AVAILABLE**

Model Number
8210

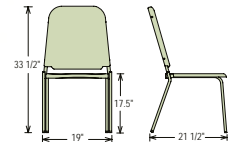

Melody Chair® Features



Optional Tablet Arm
With Plywood Core



Durable Polypropylene
Contoured Seat For
Extra Comfort



Curved, Tight Plugs



Music Band-Pitch
Style With a Seat
Back Angle Of 97°

Tablet Arms



TA82L
Left Tablet
Arm



TA82R
Right Tablet
Arm



products meet
or exceed applicable
ANSI/BIFMA standards





Music Stand Features



Tension Tilt Surface For Smooth Adjustment



Neck Assembly Provides A Tighter Fit On Pole



Rubber Tips Included To Prevent Noise And Floor Scratching

Model Number
82MS

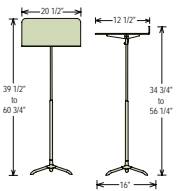

See Page 149 for Dolly Specs
 Compatible with **DOLLY**
 DYMS10, DYMS20

2 DAY LIGHTNING SHIP



ten year warranty
10

BIFMA INTERNATIONAL
ANSI

products meet or exceed applicable ANSI/BIFMA standards

CONDUCTOR'S FURNITURE



Roll With Ease Using Built-in Casters

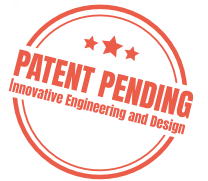

Color



Grey Carpet
 Black Side Panels
 Plywood Core

Model Number

CP2

CP Conductor Podium

Overall	12"H X 39.5"W X 44.25"D
Step	5.75"H X 39.5"W X 10.5"D

Features



Industrial Grade
 14-Gauge Frame



Carpeted Surface and
 Textured Sides for
 Modern Aesthetics



Removable Guardrail
 Also Functions as a
 Handle for Transport



Transport Vertically
 With Four Built-in
 Casters

MUSIC | CS SERIES
Conductor's Stand

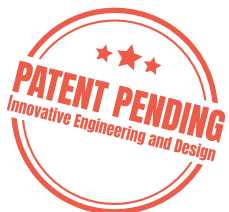

Features



Adjustable Height
Telescopic Pole



Heavy-Duty Knob
Locking Mechanism



Removable
Accessory Tray



8-Gauge Steel
Designer Base

Color



Black



Model Number
CS



CS Conductor Stand

Reading Surface	26.75" X 19.75"
Adjustable Height	33.75" - 52.75"

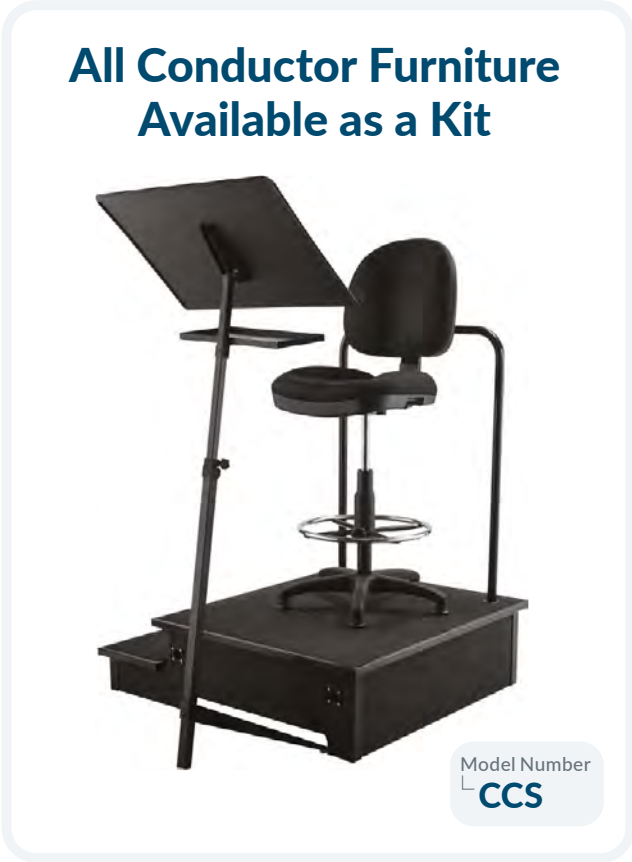

Features



Plush Padded
Seat and Back

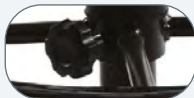

Adjustable Height
Footrest With
Locking Knob



Height Adjustable
from 24.5" to 34.5"
With Pneumatic Lift



Plastic Reinforced
Backrest and Seat

Model Number
PCC

2 DAY
LIGHTNING SHIP

10 Year
Warranty

CAL-117
RATED

TAA
OPTIONS AVAILABLE

CERTIFIED
GREEN

Fabric tested to
EXCEED 70,000
double rubs

BIFMA
INTERNATIONAL
ANSI

products meet
or exceed applicable
ANSI/BIFMA standards

ROOM DIVIDERS



ALUMINUM FRAMING
Encasing Each Panel

**BUILT-IN
MAGNETIC GANGING**



SOUND DAMPENING PET
*Noise Reduction Coefficient of .55
Sound Absorption Average of .54*



ROBUST



EASY



PORTABLE



FULL LENGTH HANDLE
For Easy Manuverability



STEEL FOOT PEDAL
LOCK RELEASE



3/16" ACRYLIC
Frosted and Clear Options

DIVIDERS
Robo Dividers



ROLL IN



FOLD



SET UP



GANG



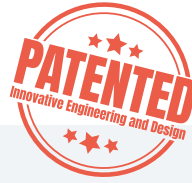

Features



Panel Position Regulators



Full Length Handle



Built-in Magnetic Ganging Mechanism on Top and Bottom



Foot-Pedal Activated Lock-Release Enables Effortless Folding



Auto-Click Panel-Locking Mechanism Keeps Panels Secure When Folded



Self-Leveling Spring Mechanism on All Casters



Each Panel Is Encased in Aluminum Framing



Tech-Lock Brake on 3" End-Panel Casters



PET Panels Are Tackable



PET Panels Are B1-Grade Flame Retardant



PET Panels Have a Noise Reduction Coefficient of 0.55 & Sound Absorption Average of 0.54



PET Panels Are Made of Environmentally Friendly Recycled Materials

Divider Lengths

6' Standard height

3 Panels
72"

5 Panels
118"

7 Panels
164"

9 Panels
210"

11 Panels
256"



Panel Type

SOUND ABSORBING PET



Grey (PT02)



Blue (PT04)



Black (PT10)

OPTIX® ACRYLIC

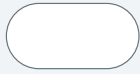

Clear (CA)

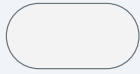

Frosted (FA)

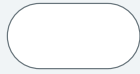

Whiteboard (WB)

Frame Color



Black (B)



Grey (G)

Model Number Configuration

Model Number Panels
RD B 6 3 PT04
Frame Color Panel Type

Base Model # Description

RDB6	Black Frame, 6ft High
RDG6	Grey Frame, 6ft High



7 DAY
QUICK SHIP

Robo Dividers with Sound Absorbing Pet (PT02, PT04 and PT10) and Clear Optix® Acrylic (CA) Panel Type







STAGES AND RISERS

Stages

S, SP, SST, TFXS, SG



Risers

RT, RS, TP,
SBRC, SCRC





Configure Your Stage

WIDTH, HEIGHT AND SURFACE TYPE



Sizes

WIDTH

36" 48"

HEIGHT

8" 16" 24" 32"

Surface Options

CARPET



Model Number Configuration

Model Number | Height
S488C-10
 Width | Surface

Features



14-Gauge Tubular Steel Legs



16-Gauge Steel Frame



0.75" Thick Plywood Core



Ganging To Easily Connect Multiple Stages



96" Standard Length

200 LBS/FT²

Tested by SGS Labs to Exceed 200 lb/Sq Ft Weight Capacity



Create Curved Configurations

Using Stage Pies

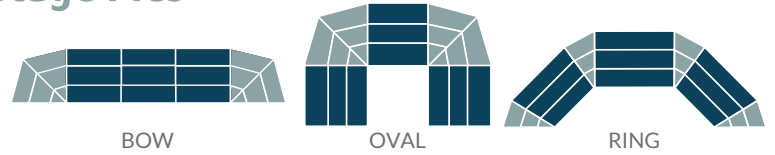

Sizes

WIDTH

36" 48"

HEIGHT

8" 16" 24" 32"

Model Number Configuration

Model Number | Height

SP36 8 C-04

Width/Depth | Surface



Surface Options

CARPET

Black (C-10) | Blue (C-04) | Grey (C-02) | Red (C-40) | Hardboard (HB)

Create Seated Risers

Single-level stages combine with gangers to create multi-level surfaces. Use below configuration codes for multi-level sets.

Straight sets



See Accessories

Page 141

Stage Packages

Page 139

Pie sets



Level Code

- 2L 2 levels; 8" and 16" Heights
- 3L 3 levels; 8", 16", and 24" Heights
- 4L 4 levels; 8", 16", 24" and 32" Heights

Model Number Configuration

Model Number | Width | Level Code

SPST 48 2L C-10

Add "P" for pie set | Surface



Choral Risers

Combine Tapered And Straight Edge Risers For Curved Configurations

Straight Edge

Code "RS"



Tapered Edge

Code "RT"

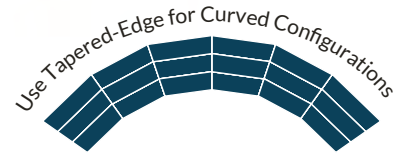

Sizes

WIDTH

18"

HEIGHT

8"

16"

24"

32"

Surface Options

CARPET



Black
(C-10)



Blue
(C-04)



Grey
(C-02)



Red
(C-40)



Hardboard
(HB)

Model Number Configuration

Edge Code | Height
RT 24 C-10
Surface

Single-level risers combine with gangers to create multi-level surfaces. Use below configuration codes for multi-level sets.



Edge Code

STRAIGHT

Code "RS"

TAPERED

Code "RT"

Level Code

2L 2 levels; 8" and 16" Heights

3L 3 levels; 8", 16", and 24" Heights

4L 4 levels; 8", 16", 24" and 32" Heights

Model Number Configuration

Edge Code | Level Code
RS 2L C-10
Surface



TransPort Riser

Available with straight or tapered edges and a fourth-level add-on

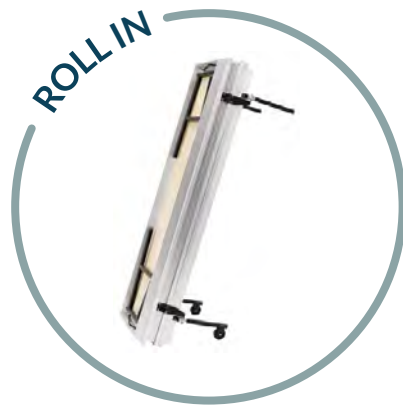

Model Numbers

- TP72 Straight Riser
- TPR72 Tapered Riser
- TPA 4th Level Straight Add-on
- TPRA 4th Level Tapered Add-on

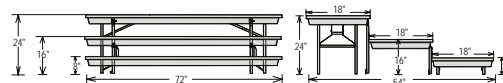

Transfix Stages

Adjustable Height Stages for Built-in Multi-Level Capabilities



Sizes

WIDTH/LENGTH

48"x48"

48"x96"

ADJUSTABLE HEIGHTS

16"/24"

24"/32"

Model Number Configuration

Prefix Width/Length

TFXS 4896 1624 C-10

 Height Surface

Surface Options

CARPET



Black (C-10)



Blue (C-04)



Grey (C-02)



Red (C-40)



Hardboard (HB)

Features

200 LBS/FT²

Tested by SGS Labs to Exceed 200 lb/Sq Ft Weight Capacity



2 Heavy Duty Casters Lift Off When Set Up



14-Gauge Legs Adjustable to Two Heights



Built in Gangers for Multi Stage Configurations

See Accessories



Page 141



Stage Packages

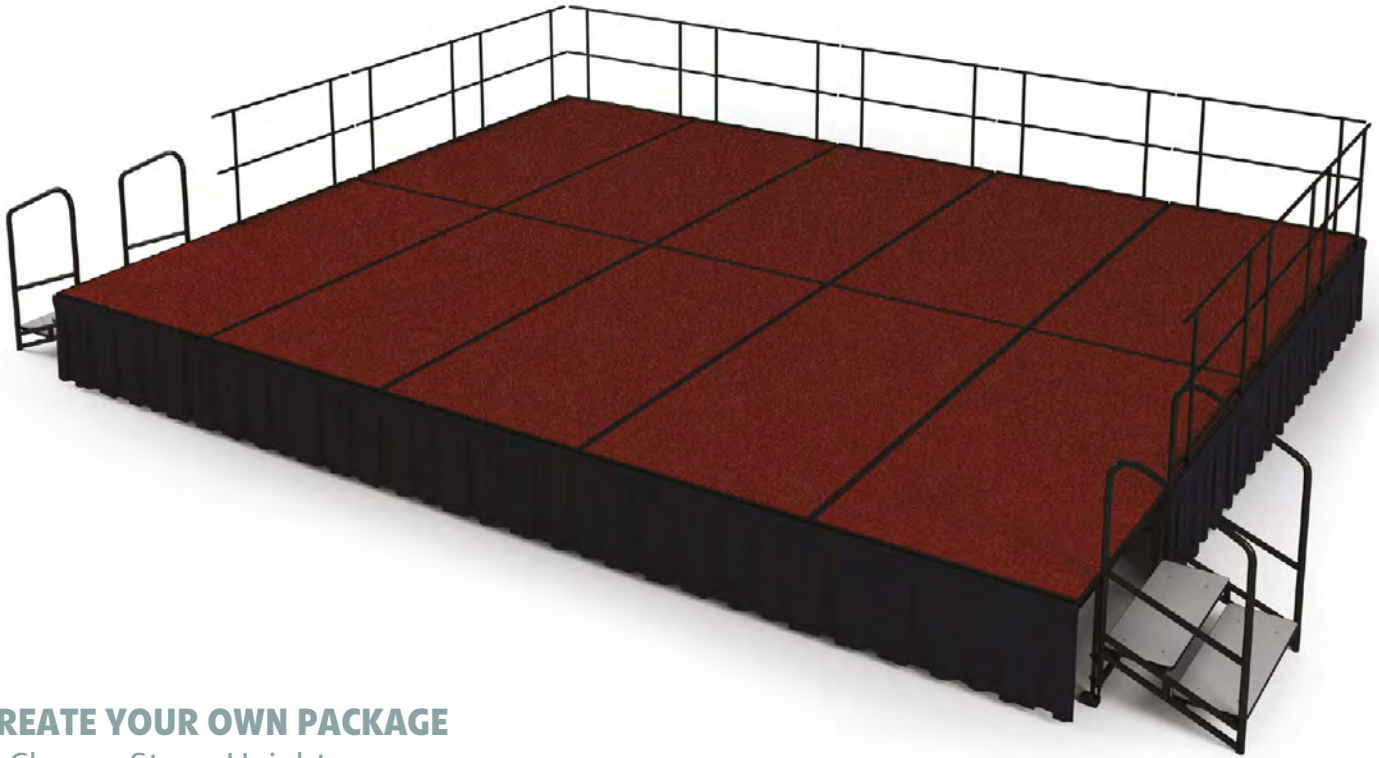

CREATE YOUR OWN PACKAGE

1. Choose Stage Height
2. Choose Quantity of Stages
3. Choose Surface Type and Color
4. Choose Skirting Type and Color

WE WILL CONFIGURE THE REST.

Each package includes guard rails on 3 sides, skirting on all sides, and 2 sets of steps.

Surface Options



Skirting Options

Type



Box pleat skirting (SB)



Shirred pleat skirting (SS)

Color



Black (10)



Navy (04)



Burgundy (08)



Green (06)

Model Number Configuration

Prefix Height QTY of Stages Surface Skirting Type Skirting Color

SG48 24 04 C-10 -SB 08

Sample Configurations

Model#	Description
SG482404	16' X 8' X 24'
SG481610	20' X 16' X 16'
SG482410	20' X 16' X 24'
SG483210	20' X 16' X 36'
SG482412	24' X 16' X 24'
SG362404	12' X 8' X 24'

Add surface and skirting codes to the end of Model #



Riser Packages

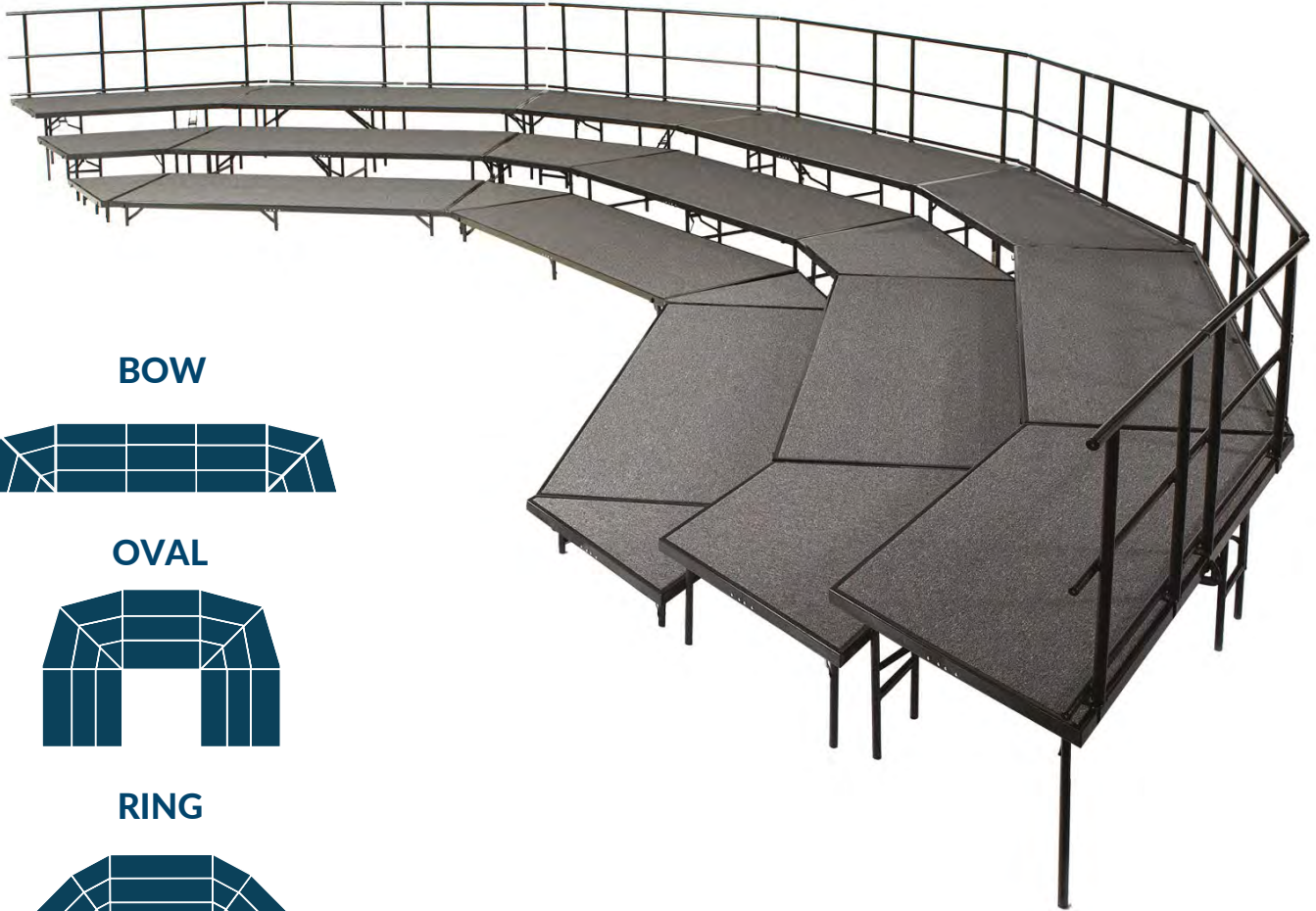

BOW



OVAL

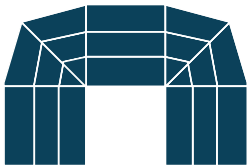

RING



Surface Options

CARPET



Use progressive heights for Seated Bands or Choral Riser Configurations

Package Options

Model#	Includes
SBRC48	3 sets of SST48 (48" x 96" straight stages) and 4 sets of compatible SPST48 (pie stages) and guard rails
SBRC36	3 sets of SST36 (36" x 96" straight stages) and 4 sets of compatible SPST36 (pie stages) and guard rails

Model Number Configuration

Base Model

SBRC48 C-10

Surface Option





A. Back Guard Rail For use with choral risers

Model#	Description
GRR24S	Back Guard Rails for 3 Level Straight Standing Choral Risers
GRR32S	Back Guard Rails for 4 Level Straight Standing Choral Risers
GRR24T	Back Guard Rails for 3 Level Tapered Standing Choral Risers
GRR32T	Back Guard Rails for 4 Level Tapered Standing Choral Risers
GRTPR3	Back Guard Rails for 3 Level TransPort Riser
GRTPR4	Back Guard Rails for 4 Level TransPort Riser

B. Side Guard Rail For use w/ standing risers in 3 heights

Model#	Description
SGRTP3	Side Guard Rails for 3 Level TransPort Riser
SGRTP4	Side Guard Rails for 4 Level TransPort Riser
SGR2L	Side Guard Rails for Standing Choral Risers
SGR3L	Side Guard Rails for Standing Choral Risers
SGR4L	Side Guard Rails for Standing Choral Risers

Chair Guard

Model#	Description
CG28	Chair Guard for SP368 Stage Pie
CG32	Chair Guard for Sides of 3' x 8' Stages
CG37	Chair Guard for SP488 Stage Pie
CG44	Chair Guard for Sides of 4' x 8' Stages
CG54	Chair Guard for SP3616 & SP4824 Stage Pie (2 EA. Needed for SP4824)
CG72	Chair Guard for SP4816 Stage Pie
CG81	Chair Guard for SP3624 Stage Pie
CG96	Chair Guard for Back of Stages (3' x 8' & 4' x 8')

C. Dolly For use with stages & seated risers (Minimum 36" widths)

Model#	Description
SDL	Stage Dolly for Use with 36" W or 48" W Stages

D. Steps For stages in 3 heights

Model#	Description
STP16	Steps for 16"H Stages
STP24	Steps for 24"H Stages
STP32	Steps for 36"H Stages

E. Stage Guard Rail

For use with stages	
Model#	Description
GRS30	30"W Guard Rail for Stages
GRS36	36"W Guard Rail for Stages
GRS48	48"W Guard Rail for Stages

Skirting Options

Model Number Configuration



Skirting Type

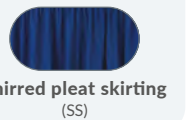

Size



Skirting Color

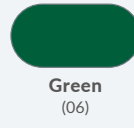
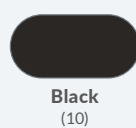

DOLLIES



Transport Options

For use with 4', 5', 6' or 8' rectangular tables

SETTING UP YOUR TABLE IS AS EASY AS 1-2-3

1. Move TAD to set-up area and open legs

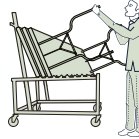

2. Gradually pull down your table



3. Allow table to rest on the floor



Features



Plastic Coated Table Support Frames



4 Swivel/ 2 Locking Casters



7/8" O.D. Steel Handle (18-Gauge)



5 X 1.25" Hard Rubber Casters



1" Square 14-Gauge Tubular Frame

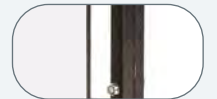

Textured Black Powder-Coated Steel

Compatible Table Series

BT1800 BT2400 BT3000 MSFT*

*Rectangle tables only

Quantity of Tables

10 5

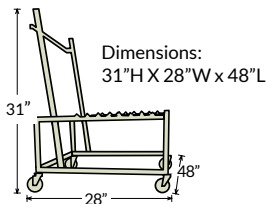

Storage and Transport Dollies

DYMU

Equipped with a Center Bar To Support Small Table Sizes



Compatible Table Series

BT2400 BT3000 BT48R BT60R

Quantity of Tables 8-10

DY-71R

Equipped with an Extra Bar For Additional Support



Compatible Table Series

BT48R BT60R BT71R

Quantity of Tables 8-10



DY-60R

Equipped with a Tubular Handle For Stability & Easy Handling



Compatible Table Series

BT48R BT60R

Quantity of Tables 8-10

DY-3072

Tables up to 72" long

DY-3096

Tables up to 96" long



Compatible Table Series

All Rectangular

Quantity of Tables 12



products meet or exceed applicable ANSIBIFMA standards



DOLLIES | 84/42-8/EXT-8/C-60 SERIES Storage and Transport Dollies

Model 84

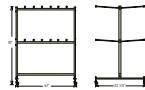

Compatible Chair Series

50 200 300 800 1200 1300 2200 2300

Quantity of Chairs **84**

Model 42-8

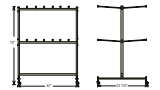

Compatible Chair Series

50 200 300 800 1200 1300 2200 2300

Quantity of Chairs **42**

Compatible Table Models

BT3072 BT3096

Quantity of Tables **8-10**



Model 84/EXT-8

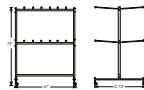

Compatible Chair Series

600 1100 1400 3200

Also any chairs compatible with 84

Quantity of Chairs **72 60 96**

Model 84-60 | 84/EXT-8-60 | 42-8-60

Convert the top level of your dolly into a coat rack by adding -60 to the end of the model number



Available Accessories



EXT-8

Available for model 84



MODEL C-60

Available for Model 84/42



products meet or exceed applicable ANSI/BIFMA standards



Storage and Transport Dollies

DY-35



USCDK Use this handle kit DY35 and DY50 for understage storage



DY-50

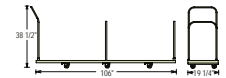

Compatible Chair Series

50	200	300	600	800	1100	1200	1300	2200	2300	3200
----	-----	-----	-----	-----	------	------	------	------	------	------

Quantity of Chairs

24	28	35	30
----	----	----	----

Compatible Chair Series

50	200	300	600	800	1100	1200	1300	2200	2300	3200
----	-----	-----	-----	-----	------	------	------	------	------	------

Quantity of Chairs

35	40	42	50
----	----	----	----



DY1100



DY1400

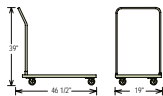

Compatible Chair Series

1100

Quantity of Chairs

26

Compatible Chair Series

1400

Quantity of Chairs

50



products meet or exceed applicable ANSI/BIFMA standards

DOLLIES | DY700/800/DY81/DY82/DY85 SERIES
Storage and Transport Dollies

DY700/800

Optional
Strap
Available
Model DYS8



Compatible Chair Series

800

Quantity of Chairs

36

DY81



Compatible Chair Series

8100 BCC

Quantity of Chairs

10

4-6



DY82



Compatible Chair Series

8210 8210-16

Quantity of Chairs

18

DY85



Compatible Chair Series

8500

Quantity of Chairs

40



products meet or exceed applicable ANSIBIFMA standards



Storage and Transport Dollies

DY87



Compatible Chair Series

8700 8800

Quantity of Chairs 35

DY87B



Compatible Chair Series

8700B 8700C 8800B 8800C

Quantity of Chairs 24



DY-9000



Compatible Chair Series

9100 9200 9300 BCC

Quantity of Chairs 8-10 4-6

DY86



Compatible Chair Series

8600

Quantity of Chairs 20



products meet or exceed applicable ANSI/BIFMA standards.

DOLLIES | DYCL-85/SDL/DYMS10/DYMS20 SERIES
Storage and Transport Dollies

DY-CL85



Compatible Chair Series
 850-CL

Quantity of Chairs 30

SDL



Compatible Stages
 36"W 48"W

Quantity of Stages 6



DYMS10



Compatible Music Stands
 82MS

Quantity of Stands 10

DYMS20



Compatible Music Stands
 82MS

Quantity of Stands 20







LECTERNS

Lecterns

GSL, 22, 112, 222, 70,
600, 401S, 611, 612



Sound Lecterns

ZED, GSL-S, 111PLS,
800x, 6010, 950/901



Greystone Lectern

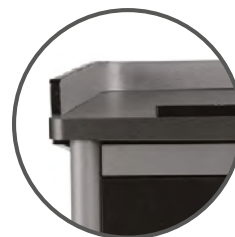

ELEGANT

Designer curved grey plywood for a more sophisticated look.



VERSATILE

Steel cabinet and hooded twin wheel matching casters allow for added storage and mobility.



MULTI-MEDIA

Large reading surface and pull-out shelves for a complete multi-media presentation experience.



Features



Sleek Grey Plywood Provides A Smooth Writing Surface



Quality Lock For Secure Storage



3" Twin Wheel TPR Two-Tone Casters



Two Shelves and Drawer for Convenient Storage

GSL SERIES GREYSTONE LECTERN

Reading Surface: 22.75"W x 18.25"D
Side pull out trays (R & L): 14.25"W x 12"D
Front pull out tray: 17.5"W x 9.25"D
Top two cabinet shelves: 21"W x 14.75"D x 7"H
Bottom cabinet shelf: 21"W x 14.75"D x 12"H
Drawer: 6.25"W x 15"D x 13.25"H
Product Weight: 89 lbs.



Full Floor Lectern
222 Series



TableTop Lectern
22 Series



Lectern Base
112 Series



222 SERIES

Colors



Medium Oak
222-MO



Mahogany
222-MY

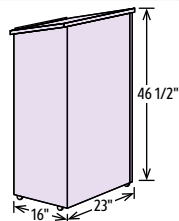

DIMENSIONS: 46.5"H
X 23"W X 16"D
WEIGHT: 56 LBS.

22 SERIES

Colors



Medium Oak
22-MO



Mahogany
22-MY



Black
22-BK

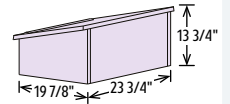

DIMENSIONS:
13.75"H X 23.75"W X 19.875"D
WEIGHT: 31 LBS.

Features



Built in Paper/
Bookstop



Convenient
Shelf for Storage

Accessories



2CS
Caster Kit
Optional for 222
included with 112

112 SERIES

Color



Black
122-BK

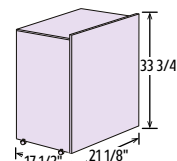

DIMENSIONS: 33.75"H
X 21.125"W X 17.5"D
WEIGHT: 50 LBS.



Portable Presentation Lectern
70 Series



Aristocrat Floor Lectern
600 Series



2 DAY
LIGHTNING SHIP

ten year
warranty
10

Features



Adjustable Height
From 30" - 44" and
Adjustable Glides



Features a
Generous 20"Wx16"L
Reading Surface

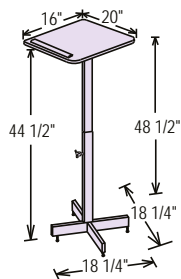

Colors



Medium Oak
70-MO

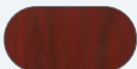

Mahogany
70-MY



Wild Cherry
70-CH

Features



4 Easy-Roll
Casters, 2
Locking



Side Mounted Slide
Out 15"Wx16"L Shelf
For A/V Presentation
Equipment

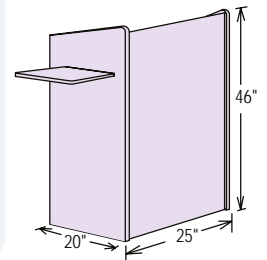

Colors



Medium Oak
600-MO



Mahogany
600-MY



Wild Cherry
600-CH

Clear Acrylic Podium 401S Series



Model Number
401S

Features



Features a
Convenient Shelf



Broad 23.5"X24"
Reading Surface



Built-in Acrylic
Book Stop

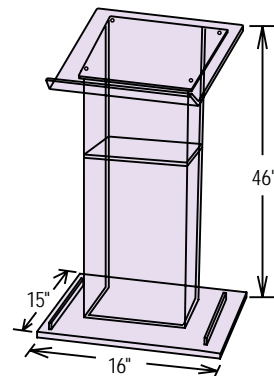

Vision LECTERNS

Vision Lectern
611 Series



Vision Lectern with Screen
612 Series



611 SERIES

Color



Ribbonwood
611-RW

Features



Four Concealed
Casters, Two Locking

Overall Dimensions: 46"Hx24"Wx21"D
Interior shelf: 14.5"Dx23"W



612 SERIES

Color



Ribbonwood
612-RW

Features



Screen Display Is
Compatible With All Popular
SD Memory Cards. No
Computer Necessary



3/4-Inch Stain and
Scratch Resistant
Thermofused Melamine
Laminate on MDF



Easy to Use
Remote Control
Operation With
On Screen Menus



Sleek Black Casing
Around LCD Display



SOUND LECTERNS

ZED Lectern

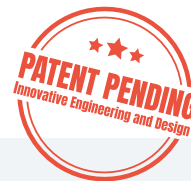

Features



Equipped With Condenser and Dynamic Microphone Inputs



Includes One Gooseneck Mic and One Tie-Clip/Lavalier Mic



Amplifier Supports Bluetooth/USB Inputs



Built-in Tone Control Capabilities



Output Lines for Auxiliary Speakers



Featuring 4 Concealed Casters



Equipped With a Halogen Lamp



Four 4" 40W Speakers



Durable Scratch Resistant Surface



High-Pressure Thermal-Fused Laminate on an MDF Core

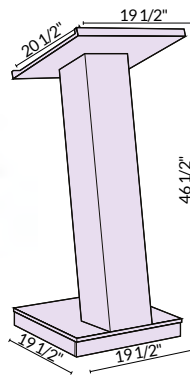

Product Feature	ZED
Overall	19.5"W x 19.5"D x 46.5"H
Reading Surface	19.5"W x 20.5"D
Product Weight	47.6 lbs.
Mics	21" Gooseneck
AMP	40W



LECTERNS | GSL-S SERIES
Greystone Lectern with Sound

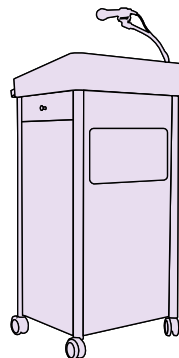

Features



Includes a Handheld Mic With 9' Cable and a Tie-Clip/Lapel Mic With 10' Cable



Equipped With Condenser and Dynamic Microphone Inputs



Amplifier Supports Bluetooth/USB Inputs and Output Lines for Auxiliary Speakers



Sleek Grey Plywood Provides A Smooth Writing Surface



Two Shelves and Drawer for Convenient Storage



3" Twin Wheel TPR Two-Tone Casters

Product Feature	GSL-S
Overall	23.5"W x 19.25"D x 45.5"H
Reading Surface	22.75"W x 18.25"D
Side Pull Out Trays (R & L)	14.25"W x 12"D
Front Pull Out Tray	17.5"W x 9.25"D
Top Two Cabinet Shelves	21"W x 14.75"D x 7"H
Bottom Cabinet Shelf	21"W x 14.75"D x 12"H
Drawer	N/A
Product Weight	95 lbs.
Mics	Handheld and Tie-clip
AMP	30W

Optional Suffix	Description
/LWM-5	Add Wireless Handheld Mic
/LWM-6	Add Wireless Tieclip Mic
/LWM-7	Add Wireless Headset Mic

Optional Prefix	Description
M	Add Rechargeable Battery

Power Plus Lectern
111PLS Series

The Orator
800X Series



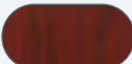

Color

Mahogany
111PLS-MY

Ribbonwood
111PLS-RW

Color

Mahogany
800X-MY

Ribbonwood
800X-RW

Upgraded Amplifier with Bluetooth/USB Inputs

Upgraded Amplifier with Goosneck Microphone and Four Concealed Casters

Base Model	Description
111PLS-MY	Power Plus Lectern - Mahogany
111PLS-RW	Power Plus Lectern - Ribbonwood

Base Model	Description
800X-MY	Orator Lectern - Mahogany
800X-RW	Orator Lectern - Ribbonwood

Optional Suffix	Description
/LWM-5	Add Wireless Handheld Mic
/LWM-6	Add Wireless Tieclip Mic
/LWM-7	Add Wireless Headset Mic

Optional Suffix	Description
/LWM-5	Add Wireless Handheld Mic
/LWM-6	Add Wireless Tieclip Mic
/LWM-7	Add Wireless Headset Mic

Optional Prefix	Description
M	Add Rechargeable Battery

Optional Prefix	Description
M	Add Rechargeable Battery

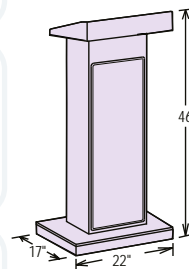
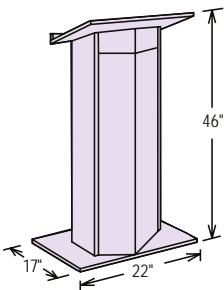



Base Model	Description
6010-MY	Aristocrat Floor Lectern - Mahogany

Optional Suffix	Description
/LWM-5	Add Wireless Handheld Mic
/LWM-6	Add Wireless Tieclip Mic
/LWM-7	Add Wireless Headset Mic

Optional Prefix	Description
M	Add Rechargeable Battery

Color



Mahogany
6010-MY

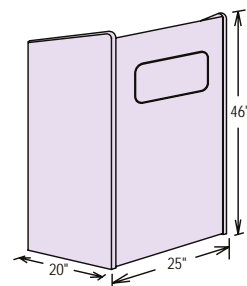

See Accessories

 Page 163

2 DAY
 LIGHTNING SHIP

ten year
 warranty
10

Veneer Lecterns

Combo Veneer Sound Lectern 950/901 Series



Upgraded Amplifier with Bluetooth/ USB Inputs Goosneck Microphone and Four Concealed Casters

Base Model	Description
950/901-MY/WT	Combo Floor Sound Lectern - Mahogany on Walnut

Optional Suffix	Description
/LWM-5	Add Wireless Handheld Mic
/LWM-6	Add Wireless Tieclip Mic
/LWM-7	Add Wireless Headset Mic

Optional Prefix	Description
M	Add Rechargeable Battery

Color

Mahogany on Walnut
950/901-MY/WT

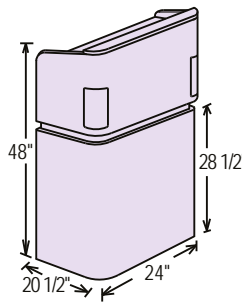



	111PLS	6010	800X	950/901	GSL-S	Zed
Dimensions	46"H X 22"W X 17"D	46"H X 25"W X 20"D	46"H X 22"W X 17"D	48"H X 24"W X 20"D	45.5" H X 23.5" W X 19.25" D	46.5" H X 19.5" W X 19.25" D
Weight	50 Lbs.	89 Lbs.	63 Lbs.	175 Lbs.	95 Lbs.	47.6 Lbs
Inside Shelf	20.5"W X 6"D	(2) 23.5"W X 18"D	12"W X 4"D	22"W X 16"D X 11"H	21"W X 14.75"D X 7"H	—
Microphones	2 Condenser Type: Handheld W/ 9' Cable; Tie-Clip Lavalier With 10' Cable	2 Condenser Type: Handheld W/ 9' Cable; Tie-Clip Lavalier With 10' Cable	1 Gooseneck Mic; One Tie-Clip/Lavalier Mic	1 Gooseneck Mic; One Tie-Clip/Lavalier Mic	2 Condenser Type: Handheld W/ 9' Cable; Tie-Clip Lavalier With 10' Cable	1 Gooseneck Mic; One Tie-Clip/Lavalier Mic
Speakers	Four 8" Full Range	Two 8" High Efficiency	Four 6" Full Range	Four 4" High Efficiency	Two 8" High Efficiency	Four 4" High Efficiency
Inputs	Two Mics, One Aux	Two Mics, One Aux	Two Mics, One Aux	Two Mics, One Aux	Two Mics, One Aux	Media Players, Extension Speakers, Usb, Bluetooth, Recording & Mp3
Wireless	Switchable; Two Frequency	Switchable; Two Frequency	Switchable; Two Frequency	Switchable; Two Frequency	Bluetooth Enabled	Bluetooth Enabled
Outputs	Line Out 1 - Extension Speaker Line Out 2 - Media Recorder	Line Out 1 - Extension Speaker Line Out 2 - Media Recorder	Line Out 1 - Extension Speaker Line Out 2 - Media Recorder	Line Out 1 - Extension Speaker Line Out 2 - Media Recorder	Line Out 1 - Extension Speaker Line Out 2 - Media Recorder	Line Out 1 - Extension Speaker Line Out 2 - Media Recorder
Controls	Four Volume, Bass/ Treble, On/Off	Four Volume, Bass/ Treble, On/Off	Four Volume, Bass/ Treble, On/Off	Four Volume, Bass/ Treble, On/Off, Bluetooth/Usb	Four Volume, Bass/ Treble, On/Off, Bluetooth/Usb	Four Volume, Bass/ Treble, On/Off, Bluetooth/Usb
Fuse	Internally Mounted, 2a	Internally Mounted, 2a	Internally Mounted, 2a	Internally Mounted, 2a	Internally Mounted, 2a	Internally Mounted, 2a
Power Supply	117 Volt Ac; 12 V Dc W/Optional Battery	117 Volt Ac; 12 V Dc W/Optional Battery	117 Volt Ac; 12 V Dc W/Optional Battery	117 Volt Ac; 12 V Dc W/Optional Battery	117 Volt Ac; 12 V Dc W/Optional Battery	117 Volt Ac; 12 V Dc W/Optional Battery
Recharger	Internally Mounted; W/Led Indicator	Internally Mounted; W/Led Indicator	Internally Mounted; W/Led Indicator	Internally Mounted; W/Led Indicator	Internally Mounted; W/Led Indicator	Internally Mounted; W/Led Indicator
Screen	—	—	—	—	—	—
Supported Formats	—	—	—	—	—	—

Available Accessories for Sound Lecterns



LWM-5
Wireless
Handheld Mic



LWM-6
Wireless
Tie-Clip/
Lavalier Mic



LWM-5
Wireless
Handheld Mic



PS12V
12V 5 Amp
Rechargeable
Battery

Model Number Configuration

Lectern Model Number Accessory Code

800XRW LWM-5

add "M" prefix to model number for rechargeable battery

PRESENTATION CARTS



The Wizard Lectern
WZD Series



Features



Surfaces Simultaneously Support: Doc Camera, LCD Projector, and Laptop



Attractive Cherry Wood Top & Base With Steel Cabinet



Sliding/ Locking LCD Projector Shelf



Storage Cabinet With Built in Power Strip

Product Feature WZD

Overall Dimensions	38"H x 25"W x 19"D
Boxed Dimensions	37"H x 25"W x 8"D
Surface Dimensions	25"W x 19"D
Laptop Shelf	16"W x 13"D
Side Shelves	16"W x 16"D
Drawer	15"W x 15"D x 2.5"H
Cabinet	23"H x 18"W x 16.5"D
Cabinet Shelf	18"W x 16.5"D
Weight	Unit 88 lbs / Boxed 99 lbs

Color

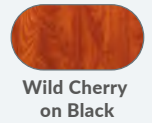

Multi Media Cart
MMC Series



Features



Dual Flip up Shelves on Both Sides for Use of a Document Camera, Laptop and Projector Simultaneously



High Pressure Thermofused Scratch Resistance Laminate on Particle Board Core



Locking Door and Drawer for Secure Storage



Front Slide-Out Laptop Shelf

Product Feature MMC

Top Surface	18" L x 21" W
Inside Dimensions	16" L x 14.5" W x 20" H
Projector Slide	16" L x 14" W
Built-In Drawer	10" L x 14" W x 5" H
Height	40" H
Side Pop-Up Shelf	14" L x 14" W

Color

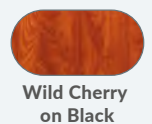

Premium Presentation Carts

Premium Presentation Cart
PRC200 Series



Premium Plus Presentation Cart
PRC250 Series



Features



Wire Management Grommets



6 Outlet Power Strip With 25' Cord With Winder



3" Casters (2 Locking)



Large Projector Shelf



Inner Shelf for Added Storage



Adjustable Height Laptop Shelf For Sitting Or Standing Position

Color



Ivory Woodgrain

Product Feature PRC200/PRC250

Dimensions	40.5"H x 18"W x 30"D
Top Shelf	18"W x 16.75"L
Laptop Shelf	18"W x 14"D
Middle Projector Shelf	16"W x 12"D
Bottom Shelf	18"W x 18"D
Weight	40 lbs
Carton size	37"L x 18"W x 5"H
Class	85
Color	Frame: Black; Shelves: Ivory wood grain
Steel	18 gauge
Paint	3 mil powder coating
Tops	Laminated on 3/4" MDF

PRC200

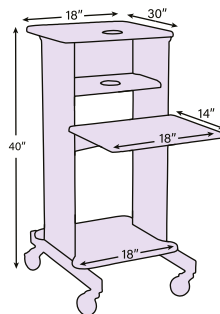

PRC250

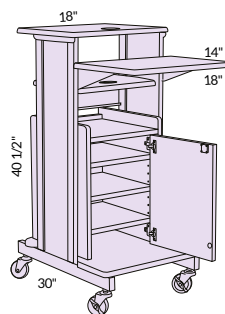

Premium Plus



Lockable Cabinet With 3 Adjustable / Removable Shelves



PRESENTATION CARTS | PRC400/PRC450 SERIES
Jumbo Presentation Carts

Jumbo Presentation Cart
 PRC400 Series

Jumbo Plus Presentation Cart
 PRC450 Series



Features

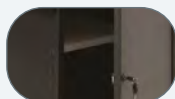

Spacious Lockable Cabinet With Adjustable Shelf

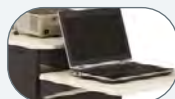

Adjustable Height Laptop Shelf for Sitting or Standing Position

Jumbo Plus



CPU Holder



6 Outlet Power Strip With 20-Foot Cord

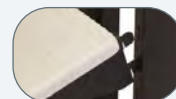

Adjustable Height Side Shelf for Document Camera or Projector

Color

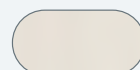

Ivory Woodgrain

Product Feature PRC400

Dimensions	40"H x 33"W x 21"D
Surface Dimensions	27"D x 21"W
Middle Projector Shelf	30.5"D x 17.5"W
Laptop Adjustable Shelf	21"W x 18"D
Locking Cabinet	25"D x 19"W x 24.75"H
Cabinet Adjustable Shelf	20"D x 19"W
Weight	100.5 lbs

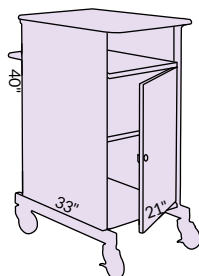

Product Feature PRC450

Dimensions	40"H x 33"W x 21"D
Surface Dimensions	27"D x 21"W
Middle Projector Shelf	30.5"D x 17.5"W
Laptop Adjustable Shelf	21"W x 18"D
Side Adjustable Shelf	24.5"W x 18"D
Locking Cabinet	25"D x 19"W x 24.75"H
Cabinet Adjustable Shelf	20"D x 19"W
Weight	117.5 lbs

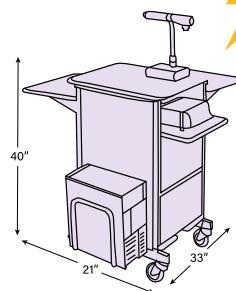

CHARGING CARTS

DUET CHARGING CART DCC Series



Model Number
DCC

Overall Dimensions: 28 1/8"W x 22"D x 38 1/4"H
Surface Dimensions: 22 3/4"W x 21 1/8"D
Shelf Dimensions: 22 1/4"W x 15 1/2"D



Features

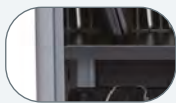

18-Gauge Heavy-Duty Steel Parts



4 Heavy-Duty 4" Casters, 2 Locking

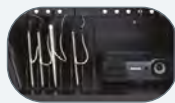

Fits 32 Laptops and Tablets With Screens up to 15.6" (up to 1" Thickness)



Adjustable Height Shelves Can Be Adjusted in 2" Increments



32 UL Approved Outlets on Built-in Power Strips



12ft Power Cord to Plug Into Wall



Maintenance Area With 4 Storage Shelves for Device Adapters



Dividers Can Be Positioned at Any Width in 1" Increments



Built in Wire Channels on Each Divider



2 Point Locking System on Front and Back Doors



Hook to Wrap the Power Cord on the Side of Cart



Grip-Rite Surface on Top of Cart

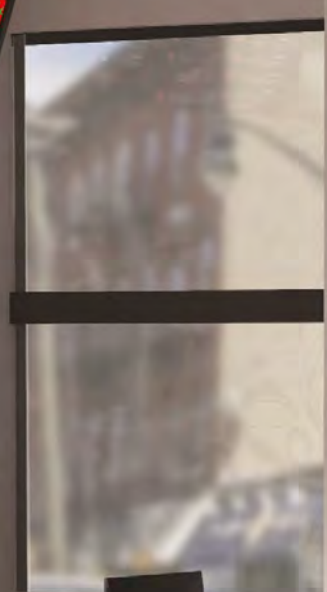
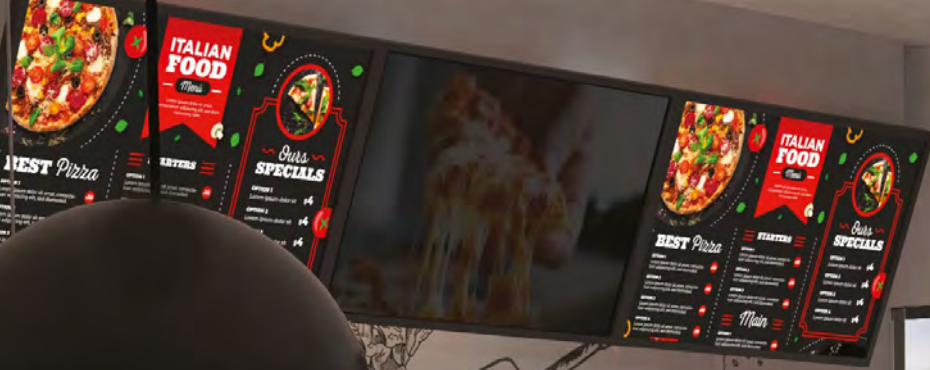



BASICS

by NPS

Banquet Chairs

9100



Stack Chairs

850-CL



Folding Chairs

900



Personal Table

PT3000



Banquet Chairs



Vinyl Colors

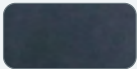

9104-B
Midnight Blue



9108-B
Pleasant Burgundy

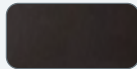

9110-B
Panther Black

Frame Color

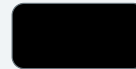

Black



Features



1" High Density
Grade-A Foam Seat



3/4" 19 Gauge
Square Tubing



Eight Plastic Stack
Bumpers for Secure
Stackability



Plywood Core
Seat and Back

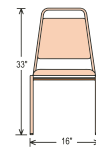



Colors



850-CL
 Black



855-CL
 Navy Blue

Features



Black
 Powdercoated
 Frame



18-Gauge,
 1/2" Steel Tubing



Built-in Ganging
 Glides Link Multiple
 Chairs Together Easily



Polypropylene
 Seat & Back



See Page 148 for

Dolly Specs



DY-CL85

Stack Up to
30
 CHAIRS

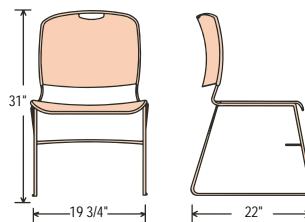

Folding Chairs

All-Steel 900 Series



Colors

-  901
Beige
-  902
Grey
-  910
Black

Vinyl Upholstered 950 Series





Colors

-  950
Black Vinyl
Black Frame
-  951
Beige Vinyl
Beige Frame
-  952
Grey Vinyl
Grey Frame

Fabric Upholstered 970 Series

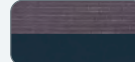

Colors

-  970
Star Trail Black Fabric
Black Frame
-  973
Star Trail Brown Fabric
Beige Frame
-  974
Star Trail Blue Fabric
Navy Blue Frame

Features



Non-Marring
Glides



19-Gauge Steel
Frame



Single Hinge



Two Tack Welded
Leg Braces

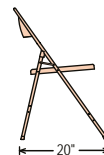
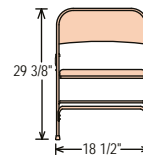



Features



1.67" Thick Tabletop

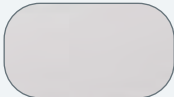

Speckled Grey Tabletop



20"x30" Tabletop



Powder Coated Textured Grey Frames and Legs



Plastic Clip to Hold Legs in Place



Glides Are Strong and Not Easily Removable



Adjustable Height Mechanism



Fully Welded Cross Brace

ADJUSTABLE TO SIX HEIGHTS

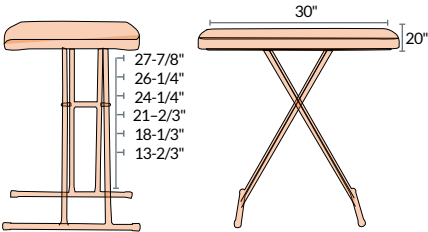

DESIGN OPTIONS Tabletop Guide



High Pressure Laminate

CORE MATERIAL	Industrial Grade Particleboard, MDF, or Plywood
FINISH	Matte Finish, Color Options Vary Per Product
EDGE	Vinyl T-Mold, 3MM PVC Edge Banding or Protect Edge
THICKNESS	Mobile Tables: 3/4" • Cafe Tables: 1-1/4" • Heavy-Duty Standard: 3/4" • Heavy-Duty Supreme: 1-1/4" • Science HPL: 1-1/8" • Togo: 1-1/4"



Chem-Res

CORE MATERIAL	Industrial Grade Particleboard with Chemical Resistant High Pressure Laminate (HPL) on Top Side, Resin Backer Sheet on Bottom Side
FINISH	Black, Matte Finish
EDGE	3MM PVC Edge Banding bonded with heated adhesive
THICKNESS	1"



Phenolic

CORE MATERIAL	Solid Phenolic Resin
FINISH	Black, Matte Finish
EDGE	1/8" Bevel Edge
THICKNESS	3/4"



Epoxy

CORE MATERIAL	Solid Epoxy Resin
FINISH	Black, Matte Finish
EDGE	1/8" Bevel Edge
THICKNESS	1"



Trespa

CORE MATERIAL	Cellulose
FINISH	Black, Matte Finish
EDGE	1/8" Bevel Edge
THICKNESS	3/4"



Whiteboard

CORE MATERIAL	Industrial Grade Particleboard with High-Pressure Laminate (HPL) Top
FINISH	Whiteboard Surface
EDGE	3MM PVC Edge Banding
THICKNESS	1.25"



Butcherblock

CORE MATERIAL	Solid Hard Maple Edge Grain Top
FINISH	Proprietary Urethane-Based Satin Finish or Natural Penetrating Oil Finish. <i>See Page 181 for Details</i>
EDGE	Long Edge Beveled • Square Ends
THICKNESS	1.75"

MAINTENANCE INSTRUCTIONS: Clean butcher block surfaces with soapy water or common kitchen counter top cleaners. Do not use abrasives or powder cleansers. Do not allow moisture to stand on the surface for prolonged periods of time.

Standard Edges *No minimum required*



Vinyl T-Molding | Black (TM)



Protect Edge | Black (PE)



3MM PVC Edge Banding | Black (EB)

Premium Edges *May be subject to minimum quantity and upcharge*

VINYL T-MOLD



Navy (TN)



Green (TG)



Red (TR)



Brown (TO)



Beige (TB)



Silver (TS)



Medium Grey (TE)



Light Grey (TL)

PROTECT EDGE



Navy (PN)



Green (PG)



Red (PR)



Purple (PP)



Beige (PB)



Dark Grey (PD)



Medium Grey (PM)



Light Grey (PL)

3MM PVC
EDGE BANDING



Navy (EN)



Green (EG)



Red (ER)



Purple (EP)



Beige (EE)



Dark Grey (ED)



Medium Grey (EM)



Light Grey (EL)

Stool Top Color Options



Grey (02)



Blue (04)



Green (06)



Burgundy (08)



Black (10)



Yellow (25)



Purple (28)



Red (40)



Pacific Blue (14)



Pea Pod (16)



Tangerine (17)

Custom Logo Options

Upcharge and extended lead times apply | Custom Graphic Laminates are available on Tabletops with Particleboard and MDF core only.



High Pressure Laminates

Standard Laminates

No minimum required



Robin
RN



Port
PO



Regimental Red
RR



Hollyberry
RE



Candy Apple
CD



Dragon Fire
DF



Orange Grove
OG



Hunter Green
GR



Morrocan
MA



Ocean
OC



Persian Blue
BL



Lapis Blue
LB



Catalina
CI



Indigo
IN



Black
BK



Graphite Nebula
GN



Asian Night
AN



Rustic Slate
RS



Forged Steel
FS

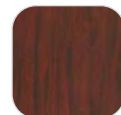

Figured Mahogany
MY



Coffee Bean
CB



Windsor Mahogany
WM



Lowell Ash
LA



Burnished Chestnut
CT



Buka Bark
KB



River Cherry
RC



Nepal Teak
NT



Wild Cherry
CH



Bannister Oak
OK



Castle Oak
CO

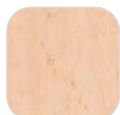

Limber Maple
LM



Kensington Maple
KS



Fusion Maple
FM

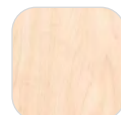

Manitoba Maple
MT

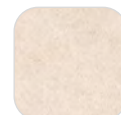

Almond Leather
AL



Natural Nebula
NN



Steel Mesh
SL



Slate Grey
SG



Mystic Night
MN



Pewter Brush
PB



Windswept Pewter
WP

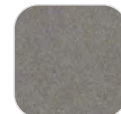

Twilight Zephyr
TZ



Sheer Mesh
SM



Crisp Linen
CL



High Rise
HR



Frosty White
FW



White Sand
WS



Titanium EV
EV



Carbon Ev
CE



Evening Tigris
ET



Bronze Legacy
BZ



Nickel
NE



Pearl Soapstone
PS



Grey Glace
GG



Grey Nebula
GY



Platinum
PL



Fashion Grey
GF



White Nebula
WN

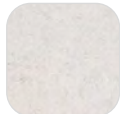

White Tigris
TW



Grey
RG



Grey Pampas
PP

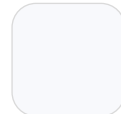

Designer White
DW



Blackbird
CK

Premium Laminates

Minimum Quantity, Upcharge and 10 week lead time apply

						
Maroochy Brush MB	Marigold YW	Sprout SU	Island IS	Marmalade ML	Quince QN	Wheat Berry BY
						
Atlantis AT	Brittany Blue BB	Woolamai Brush WO	Navy Legacy NL	Kale Leaf KL	Blue Curacao CR	Biltmore Cherry BC
						
Montana Walnut WT	Windswept Bronze WZ	Pinnacle Walnut PN	Concord Grape CG	Williamsburg Cherry WC	Xanadu XD	Skyline Walnut SW
						
Fonthill Pear FP	Harvest Maple HM	New Age Oak NW	Monticello Maple MP	Charcoal Velvet CV	Deepstar Agate DS	White Cypress CY
						
Tawny Legacy TL	Natural Almond NA	Desert Zephyr DZ	Natural Tigris NG	White Driftwood WD	Grey Elm GE	Portico Teak PT
						
Boardwalk Oak BD	Pewter Mesh PW	Green Tigris GT	Dove Grey DG	Italian Silver Ash IA	Cosmic Strandz CS	Ink Vesta IV
						
Tailored Linen TA	North Sea NS	Pressed Linen LN	Cloud Nebula CN	Gold Alchemy GA	Whiteboard WB	

**IF YOU DON'T
SEE A LAMINATE,
JUST ASK!**

Choose any laminates from:

May be subject to minimum quantity and upcharge



Custom Banquet Chairs

MOQ, upcharge and extended lead time apply

Fabrics



Midnight Blue
54



Ebony Black
60



Natural Chocolatier
61



Natural Greystone
62



Diamond Navy
64



Natural Blue
74



Natural Taupe
78



Auburn
F201



Brown
F202



Charcoal
F203



Cobalt
F204

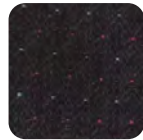

Black Patterned
F205

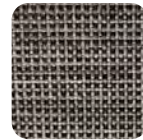

Fossil
F206



Golden Burgundy
F207



Grape
F208



Brown Dot
F209



Grey Dot
F210

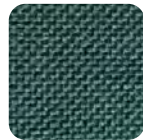

Hunter Green
F211



Indigo
F212



Mixed Tan
F214



Pink Grape
F215



Purple
F216



Red Rose
F217



Walnut
F218



Diamond Burgundy
F219



Graphite
F220

Vinyls



French Beige
01



Midnight Blue
04



Pleasant Burgundy
08



Panther Black
10



Black
V101

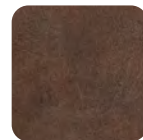

Dark Brown
V102



Cobalt Blue
V103



Tan
V104



Burgundy
V105



Medium Brown
V106



Textured Black
V107

Model # Description

93	9300 Series Silhouette Stack Chair
92	9200 Series Dome Stack Chair

Frames



Black Santex
BT



Silvervein
SV



Mocha
M

Model Number Configuration



Custom Phenolics and Butcherblock Finishing Options

Black Core Phenolic

MOQ, upcharge and extended lead time apply



PFG705



PFS729



PBW954



PMO829

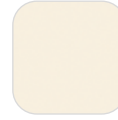

PAL029



PFO9435



PLG0428



PGS3978



PSR938



PNB6697



PSO5328



PEA2435



PPU858



PMJ1578



PNB969

Color Thru Phenolic

MOQ, upcharge and extended lead time apply



PB909CT



PNB969CT



PMO829CT



PMJ1578CT

Butcherblock Finishing Options

STANDARD



Urethane-Based Satin Finish

Code: BB

CORE MATERIAL	Solid Hard Maple Edge Grain Top
FINISH	Proprietary Urethane-Based Satin Finish
EDGE	Long Edge Beveled • Square Ends
THICKNESS	1.75"
FOOD SAFE	Yes

MAINTENANCE Recommended to re-finish every 2-3 weeks depending on usage.



Refinishing can be done fairly quickly using a rag and Emmet's Good Stuff Gel Urethane

CUSTOM



Varnique Semi-Gloss Finish

Upcharge and Extended Lead Time apply

Code: BV

CORE MATERIAL	Solid Hard Maple Edge Grain Top
FINISH	Natural Penetrating Oil Finish
EDGE	Long Edge Beveled • Square Ends
THICKNESS	1.75"
FOOD SAFE	Yes

MAINTENANCE Recommended to re-finish every 3-4 weeks depending on usage.



Refinishing can be done fairly quickly using a rag and Boos® EZ-DO Finish



Limited Warranty: Since Natural Wood Products rely heavily on the care they receive, Butcherblock Tabletops have One Year Warranty. The rest of the parts of the product still carry a Ten Year Warranty.

NPS Product Specifications

FOLDING CHAIRS







50 SERIES / STEEL FOLDING CHAIR

DIMENSIONS: OVERALL: 29 3/8"H X 18 1/2"W X 20"D
FOLDED: 38"H X 18 3/4"W X 2"D
SEAT: 16 3/4"H X 15 3/4"W X 16"D / BACK: 8 3/4"H X 18 3/4"W

- Electromagnetically welded seat back
- Features 19-gauge 7/8" round tubular frame with 2 1/2" frame strengthener
- Powder-coated frame
- Two 19-gauge 5/8" U-shaped double riveted cross braces
- Single hinge on each side for added stability and durability
- Color coordinated V-tip plugs for added stability
- Color coordinated polypropylene glides
- Seat with a waterfall front for added comfort
- 500 lbs. static load weight capacity
- Available Colors:  Beige  Grey  Black





200 SERIES / STEEL PREMIUM FOLDING CHAIR

DIMENSIONS: OVERALL: 29 5/8"H X 18 3/8"W X 19 1/2"D
FOLDED: 38"H X 18 1/4"W X 2"D
SEAT: 17 1/4"H X 16"W X 16"D / BACK: 8 1/4"H X 18 1/4"W

- Electromagnetically welded seat back
- Two U-shaped double riveted cross braces
- Features 18-gauge 7/8" round tubular frame
- Powder-coated frame
- Double hinges on each side for added stability and durability
- Color coordinated V-tip plugs for added stability
- Color coordinated polypropylene glides
- Features our unique full size double contoured square back and waterfall seat
- 500 lbs. static load weight capacity
- Available Colors:  Beige  Grey  Brown  Char-Blue  Black  Red





300 SERIES / STEEL TRIPLE BRACE FOLDING CHAIR

DIMENSIONS: OVERALL: 29 1/2"H X 18 7/8"W X 20"D
FOLDED: 38"H X 18 1/4"W X 2"D
SEAT: 17 1/4"H X 16"W X 16"D / BACK: 8 1/4"H X 18 1/4"W

- Features 18-gauge 7/8" round tubular frame
- Three U-shaped double riveted cross braces
- Powder-coated frame
- Electromagnetically welded seat back
- Features our unique full size double contoured square back and waterfall seat
- Double hinges on each side for added stability and durability
- Color coordinated V-tip plugs for added stability
- Color coordinated polypropylene glides
- 500 lbs. static load weight capacity
- Available Colors:  Beige  Grey  Brown  Char-Blue  Black





600 SERIES / BLOW MOLDED RESIN PLASTIC FOLDING CHAIR

DIMENSIONS: OVERALL: 32"H X 18 3/4"W X 21 1/2"D
FOLDED: 42 1/2"H X 18 3/4"W X 3"D
SEAT: 18"H X 15 3/4"W X 16 5/8"D / BACK: 9 1/4"H X 18 3/4"W

- Features 19-gauge 1" O.D. steel frame with metal underbracing on seat for added durability
- Two cross braces for strength
- Powder-coated frame
- Single hinges on each side for added stability and durability
- Lightweight indoor/outdoor use
- Contoured seat and back for comfort
- 500 lbs. static load weight capacity
- Available Colors:  Light Grey seat/back and textured powder coated Grey frame
 Red or Blue seat/back and powder coated Black frame
 Charcoal Slate Plastic/Silvertone Frame
 Black Plastic/Black Frame



800 SERIES / PREMIUM LIGHTWEIGHT FOLDING CHAIRS

DIMENSIONS: OVERALL: 29 3/4"H X 18 3/4"W X 20 3/4"D
FOLDED: 38"H X 18 3/4"W X 2 1/2"D
SEAT: 18"H X 15 3/4"W X 16 1/4"D / BACK: 7 1/2"H X 18 1/2"W

- Features 18-gauge 7/8" round tubular frame
- Two U-shaped double riveted cross braces
- Powder-coated frame
- Double hinges on each side for added stability and durability
- Color coordinated V-tip plugs for added stability
- Color coordinated polypropylene glides
- Features a color-impregnated plastic seat and back
- Stacks up to 80" high (36 chairs) with specially designed stacking tabs
- Weight only 8.5lbs.
- 500 lbs. static load weight capacity
- Available Colors:  Grey/Grey  Blue/Grey  Burgundy/Black
 Black/Black  Bright White/White





1100 SERIES / POLYFOLD FAN-BACK FOLDING CHAIR

DIMENSIONS: OVERALL: 34 1/2"H X 18 1/2"W X 20 3/4"D
FOLDED: 44"H X 18 1/2"W X 20 3/4"D
SEAT: 17 3/4"H X 15 3/4"W X 16"D / BACK: 13 1/2"H X 18 3/4"W X 4"D

- Features 18-gauge 7/8" round tubular frame
- Three U-shaped double riveted cross braces
- Powder-coated frame
- Double hinges for added stability and durability
- Color coordinated V-tip plugs for added stability
- Color coordinated polypropylene glides
- Features our unique full size double contoured high back and waterfall seat
- Stacks up to 26 High
- 500 lbs. static load weight capacity
- Available Colors:  Blue Plastic/Grey Frame  Dark Blue Plastic/Grey Frame
 Black Plastic/Black Frame





1200 SERIES / PREMIUM STEEL VINYL FOLDING CHAIR

DIMENSIONS: OVERALL: 29 1/2"H X 18 3/4"W X 20 1/4"D
FOLDED: 38"H X 18 1/4"W X 2 1/2"D
SEAT: 17 3/4"H X 16"W X 16"D / BACK: 8 3/4"H X 18 3/4"W

- Features 18-gauge 7/8" round tubular frame
- Two U-shaped double riveted cross braces
- Powder-coated frame
- Double hinges for added stability and durability
- Color coordinated V-tip plugs for added stability
- Color coordinated polypropylene glides
- Features our unique full size double contoured back and waterfall seat
- Vinyl and Foam are Cal 117 rated
- .80MM Vinyl over 1 1/4", 0.9lb. density foam seat and 1.2lb. density back
- Fully upholstered seat and back attached with 6 rivets
- 500 lbs. static load weight capacity
- Available Colors:  French Beige/Beige  Warm Grey/Grey
 Honey Brown/Beige  Dark Midnight Blue/Blue
 Caviar Black/Black

1300 SERIES / PREMIUM STEEL VINYL FOLDING CHAIR

DIMENSIONS: OVERALL: 29 1/2"H X 18 3/4"W X 20 3/4"D
FOLDED: 38"H X 18 1/4"W X 2 1/2"D
SEAT: 17 3/4"H X 16"W X 16"D / BACK: 8 3/4"H X 18 3/4"W

- Features 18-gauge 7/8" round tubular frame
- Three U-shaped double riveted cross braces
- Powder-coated frame
- Double hinges for added stability and durability
- Color coordinated V-tip plugs for added stability
- Color coordinated polypropylene glides
- Features our unique full size double contoured back and waterfall seat
- Vinyl and Foam are Cal 117 rated
- .80MM Vinyl over 1 1/4", 0.9lb. density foam seat and 1.2lb. density back
- Fully upholstered seat and back attached with 6 rivets
- 500 lbs. static load weight capacity
- Available Colors:  French Beige/Beige  Warm Grey/Grey  Dark Midnight Blue/Char-Blue
 Caviar Black/Black  Honey Brown/Beige

NPS Product Specifications

1400 SERIES / AIRFLEX® FOLDING CHAIR

DIMENSIONS: OVERALL: 32" H X 21.5" W X 20.75" D
FOLDED: 40.25" H X 19.50" W X 2" D
SEAT: 8" H X 17" W X 18" / BACK: 7.5" H X 19.5" W / WEIGHT: 9.6 LBS.

- Features 18-gauge steel frame for lasting durability
- 7/8" square leg tubing for added strength
- Seat strengthened with 2 side 11 gauge steel supports
- Durable Industrial Grade 3.8MM Polypropylene
- Backrest secured with rivets
- Nesting/Stacking assist glide
- Designed for easy stacking
- Oversized 18" seat
- 1000 Lb. weight capacity
- Sweat-free ventilation
- 1000 lbs. weight capacity
- Available colors: ■ Black ■ White

2200 SERIES / PREMIUM STEEL FABRIC FOLDING CHAIR

DIMENSIONS: OVERALL: 29 1/2"H X 18 3/4"W X 20 1/4"D
FOLDED: 38"H X 18 1/4"W X 2 1/2"D
SEAT: 17 3/4"H X 16"W X 16"D / BACK: 8 3/4"H X 18 3/4"W

- Features 18-gauge 7/8" round tubular frame
- Two U-shaped double riveted cross braces
- Powder-coated frame
- Double hinges on each side for added stability and durability
- Color coordinated V-tip plugs for added stability
- Color coordinated polypropylene glides
- Features our unique full size double contoured back and waterfall seat
- Fabric is rated to 30,000 double rubs
- Fabric and Foam are Cal 117 rated
- Institutional grade fabric over 1 1/4", 0.9lb. density foam seat and 1.2lb. density back
- 500 lbs. static load weight capacity
- Available Colors: ■ Café Beige/Beige ■ Greystone/Grey ■ Imperial Blue/Blue ■ Imperial Blue/Grey ■ Russet Walnut/Brown ■ Majestic Cabernet/Grey ■ Midnight Black/Black

2300 SERIES / PREMIUM STEEL FABRIC FOLDING CHAIR

DIMENSIONS: OVERALL: 29 1/2"H X 18 3/4"W X 20 3/4"D
FOLDED: 38"H X 18 1/4"W X 2 1/2"D
SEAT: 17 3/4"H X 16"W X 16"D / BACK: 8 3/4"H X 18 3/4"W

- Features 18-gauge 7/8" round tubular frame
- Three U-shaped double riveted cross braces
- Powder-coated frame
- Double hinges on each side for added stability and durability
- Color coordinated V-tip plugs for added stability
- Color coordinated polypropylene glides
- Features our unique full size double contoured back and waterfall seat
- Fabric and Foam are Cal 117 rated
- Scotchguarded fabric is rated to 30,000 double rubs
- Institutional grade fabric over 1 1/4", 0.9lb. density foam seat and 1.2lb. density back
- 500 lbs. static load weight capacity
- Available Colors: ■ Café Beige/Beige ■ Greystone/Grey ■ Imperial Blue/Blue ■ Majestic Cabernet/Grey ■ Midnight Black/Black

3200 SERIES / PREMIUM STEEL FABRIC OR VINYL FOLDING CHAIR

DIMENSIONS: OVERALL: 32"H X 18 3/4"W X 20 3/4"D
FOLDED: 39 3/4"H X 18 3/4"W X 3 3/4"D
SEAT: 18 1/2"H X 15 3/4"W X 15 1/2"D / BACK: 8 3/4"H X 18 3/4"W

- 2" Upholstered box seat on a masonite board with 8 rivets
- Features 18-gauge 7/8" round tubular frame
- Two U-shaped double riveted cross braces
- Powder-coated frame
- Double hinges on each side for added stability and durability
- Color coordinated V-tip plugs for added stability
- Color coordinated polypropylene glides
- Fabric and Foam are Cal 117 rated

- Fabric is rated to 30,000 double rubs
- Institutional grade fabric over 1 1/4", 0.9lb. density foam seat and 1.2lb. density back
- Padded backs are fully covered in fabric or vinyl on both sides
- 300 lbs. weight capacity
- Available Colors: ■ Charcoal Grey Fabric/Black Frame ■ Regal Blue Fabric/Grey Frame ■ New Burgundy Fabric/Grey Frame ■ Antique Gold Fabric/Brown Frame ■ Black Vinyl/Black Frame ■ Beige Vinyl/Beige Frame

5200 SERIES / PREMIUM STEEL FOLDING CHAIR WITH TABLET ARM (LEFT OR RIGHT)

DIMENSIONS: OVERALL: 29 1/2"H X 20 1/2"W X 28 3/4"D; TABLET ARM 5/8" H X 22L" X 11" W
FOLDED: 38"H X 18 1/4"W X 4"D
SEAT: 17 1/4"H X 16"W X 16" D / BACK: 8 1/4"H X 18 1/4"W

- Features 18-gauge 7/8" round tubular frame
- Two U-shaped double riveted cross braces
- Powder-coated frame
- Double hinges on each side for added stability and durability
- Color coordinated V-tip plugs for added stability
- Color coordinated polypropylene glides
- Features our unique full size double contoured square back and waterfall seat
- 500 lbs. static load weight capacity
- Available Colors: ■ Grey Tablet Arm/Black Frame

STACK CHAIRS

8100 SERIES / POLY SHELL CHAIR

DIMENSIONS: OVERALL: 31"H X 19 1/4"W X 19 1/4"D
SEAT: 18"H X 17"W X 16 3/4"D
OPTIONAL TABLET ARM: 5/8"H X 11"W X 23 1/2"D - WRITING SPACE: 12 1/2"L X 11"W

- Features a chrome plated frame with 17-gauge 7/8" square tubing
- 3 underseat cross braces for added stability and durability
- Features a one piece, injection molded, color-impregnated, high-density polypropylene seat/back
- Shell and frame shields to protect against snags and pinching
- Anti-static shell
- Can be stacked 12 high with 6 stack bumpers on each chair to protect finish
- 300 lbs. weight capacity
- Available Colors: ■ Black ■ Blue

8500 SERIES / HI-TECH ULTRA COMPACT STACKER

DIMENSIONS: OVERALL: 31"H X 17 1/2"W X 22 1/2"D
SEAT: 17"H X 17 1/2"W X 17 1/4"D

- Optional removable bookrack & tablet arm; Tablet arm measures 11 1/2" x 20" laminated in Black, Writing space 11"L x 11 1/2"W
- Features an 11 mm solid steel rod with chrome plated frame
- Injection molded textured polypropylene plastic seat and back
- Specialized polyethylene glide with enhanced notching system for secure fit
- Reinforced underseat ribbing and EZ-Grip handle for added durability when lifting and stacking
- Optional ganging clamps available
- Can stack up to 40 high on DY85 dolly
- 300 lbs. weight capacity
- Available Colors: ■ Gunmetal ■ Navy ■ Wine ■ Black

8600 SERIES / SIGNATURE LIGHTWEIGHT FABRIC PADDED STACK CHAIR

DIMENSIONS: OVERALL: 33"H X 19"W X 21"D
SEAT: 19"H X 16"W X 16"D

- Features a 5/8" 17-gauge tubular frame with 5/8" frame strengthener
- Contoured Seat and Back for Enhanced Comfort
- Fabric and Foam are Cal-117 Rated
- Fabric is rated to 150,000 double rubs
- Non-Marring floor glides
- Can stack up to 20 high with our DY-86 Dolly (19"W x 36"D x 57"H)
- 300 lbs. weight capacity
- Available Colors: ■ Black ■ Classic Grey

NPS Product Specifications

8700 SERIES / THE CAFETORIUM VINYL PADDED STACK CHAIR

- 16 gauge ½" round tubing fitted with 2" long & ¾" thick Nylon Ganger/ glides
- TPU floor protector bottoms
- Back made of .21" (5.5mm) thick polypropylene
- Back assembled to frame with two tamper-free screws
- Seat upholstered with ISO-9002 certified 0.8m thick vinyl
- 5/8" foam thickness; 1.3 foam density
- Upholstered seat on multi-ribbed plastic seat base
- 12-gauge steel cross braces
- Can stack up to 35 high with our DY-87 Dolly (20 1/4"H x 35"D x 75"H)
- Cal 117 rated
- 300 lbs. weight capacity
- Available Colors: ■ 8704-10-04 ■ 8710-11-10 ■ 8742-12-02

8800 SERIES / THE CAFETORIUM POLY STACK CHAIR

- 18 gauge 1/2" round tubing fitted with 2" long & ¾" thick Nylon Ganger/ glides
- TPU floor protector bottoms
- Seat and back made of .21" (5.5mm) thick polypropylene
- Back assembled to frame with two tamper-free screws
- 12-gauge steel cross braces
- Can stack up to 35 high with our DY-87 Dolly (20 1/4"H x 35"D x 75"H)
- Cal 117 rated
- 300 lbs. weight capacity
- Available Colors: ■ 8804-11-04 ■ 8810-11-10 ■ 8818-11-18 ■ 8820-11-20

BANQUET STACK CHAIRS

9100 SERIES / BASICS BY NPS

DIMENSIONS: OVERALL: 32 1/2"H X 17 3/4"W X 21 1/2"D
SEAT: 17 1/2"H X 16"W X 16 1/8"D

- Features a Sturdy 3/4" square frame 19-gauge steel tubing with non-marring plastic glides
- Steel Standard: ASTM A513
- Foam Standard: 1.8lb. density, 46 ILD
- Seat is cushioned with 1" of high-density Grade A foam
- Vinyl & Foam are Cal-117 rated
- Available with thick .80MM vinyl
- Tapered back has built-in handhold
- Eight plastic stack bumpers protect the powder-coated frame finish
- Stack 8-10 high with DY81 or DY9000 dollies
- Nylon glides
- 300 lbs. weight capacity
- Available Vinyl Upholstery Colors: ■ Pleasant Burgundy ■ Panther Black ■ Midnight Blue
- Available Frame Colors: ■ Black

9200 SERIES / DOME-BACK STACKER

DIMENSIONS: OVERALL: 34 3/4"H X 17 3/4"W X 20 1/2"D
SEAT: 18 7/8"H X 15 1/2"W X 16"D

- Features a 7/8" Square-tube 18-gauge steel frame with 5/8" under seat and H-braces
- Steel Standard: ASTM A513
- Foam Standard: 1.8lb. density, 46 ILD
- 2" thick Grade A foam; cushion is double stitched with a spacious 34"H x 16"W x 16"D waterfall seat
- Available in choice of institutional grade fabrics rated to 67,000-130,000 double rubs or thick .80MM vinyl
- Fabric and Foam are Cal-117 Rated
- The back has a convenient handhold for easier moving and stacking
- Stacking bars and 12 plastic stack bumpers ensure stacking securely without damaging the attractive powder-coated frame finish.
- Stack 8-10 high with DY81 or DY9000 dollies
- Nylon glides
- 500 lbs. static load weight capacity
- Available Fabric colors: ■ Midnight Blue ■ Ebony Black ■ Burgundy
- Available Upholstery color: ■ Diamond Navy

- Available Vinyl colors: ■ French Beige ■ Midnight Blue ■ Panther Black
- Available Chair frame colors: ■ Mocha (available with French Beige Vinyl only) ■ Silvervein ■ Black Santex

9300 SERIES / SILHOUETTE STACKER

DIMENSIONS: OVERALL: 37 1/4"H X 17 1/4"W X 21 3/4"D
SEAT: 18 7/8"H X 15 1/2"W X 16"D

- Features a 7/8" Square-tube 18-gauge steel frame with 5/8" under seat and H-braces
- Steel Standard: ASTM A513
- Foam Standard: 1.8lb. density, 46 ILD
- Waterfall seat, padded with 2" of 1.8lb. high-density Grade A foam with double-stitched box seat
- Features a concealed double back with 4 covered metal tabs for a more refined look.
- Available in choice of institutional grade fabrics rated to 67,000-130,000 double rubs or thick .80MM vinyl
- Fabric and Foam are Cal-117 rated
- Nylon glides won't scuff floors
- Built-in stack bar and 12 plastic stack bumpers help prevent wear and tear
- Stack 8-10 high with DY81 or DY9000 dollies
- 500 lbs. static load weight capacity
- Available Fabric/Frame color combos: ■ Midnight Blue Fabric/Silvervein Frame ■ Ebony Black Fabric/Black Santex Frame ■ Natural Chocolatier Fabric/Black Santex Frame ■ Natural Greystone Fabric/Black Santex Frame ■ Diamond Navy Fabric/Silvervein Frame ■ Diamond Burgundy Fabric/Silvervein Frame ■ Natural Blue Fabric/Black Santex Frame ■ Natural Taupe Fabric/Black Santex Frame ■ Midnight Blue Vinyl/Silvervein Frame ■ Panther Black Vinyl/Black Santex Frame ■ Panther Black Vinyl/Black Silvervein Frame

MOBILE CHAIR

COGO / MOBILE TABLET CHAIR

DIMENSIONS: TOTAL HEIGHT: 34" TOTAL WIDTH: 24.75" (W/TABLET IN SIDE POSITION)
SEAT: 17.5"W X 18.75"H X 16"D / TABLET: 19.5"W X 13.75"D
UNDER SEAT STORAGE: 16.75"W X 16.75"D
/ WEIGHT: 25LBS.

- Ergonomically designed for all-day seating support
- Fiberglass-reinforced polypropylene
- Features a tablet holder
- 440 lbs. weight capacity
- Heavy duty 16-gauge steel
- Strong twin wheeled 2" casters
- Optional glides available
- Steel washer plates are welded onto the frame and a steel tab is welded onto the arm, providing firm support and preventing the arm from sagging.
- Tablet can be installed on right or left side and boasts a 150 lbs. weight capacity
- Available seat colors: ■ Red ■ Black ■ Blue
- Available base and tablet colors: ■ Grey

CADDIES / DOLLIES

42-8 / CHAIR CADDY

DIMENSIONS: OVERALL: 67" W x 33 1/4"D x 70"H - weight 88 lbs.

- 7-gauge main frame features channeled steel with tube in tube design at peak stress point of frame for added strength and stability
- 14-gauge cross braces
- 16-gauge hanging rods
- Heavy-duty caster features 325lb. weight capacity and measures 4" x 1 1/4"
- Swivel wheels for easy gliding
- Chair capacity to hold 42 chairs and 8-10 tables either steel or plastic
- Dark Brown Powder Coated Steel
- Not for use with BT3060

MODEL 42-8-60 / CHAIR CADDY

DIMENSIONS: OVERALL: 67" W X 33 1/4"D X 70"H - WEIGHS 102LBS.

- 7-gauge main frame features channeled steel with tube in tube design at peak stress point of frame for added strength and stability
- 14-gauge cross braces

NPS Product Specifications

- 16-gauge hanging rods
- Heavy-duty caster features 325lb. weight capacity and measures 4" x 1 1/4"
- Swivel wheels for easy gliding
- Chair capacity to hold 42 chairs and 8-10 tables
- Includes two coat rods
- Dark Brown Powder Coated Steel

84 / CHAIR CADDY

DIMENSIONS: OVERALL: 67"W X 33 1/4"D X 70"H - WEIGHT 100 LBS.

- 7-gauge main frame features channeled steel with tube in tube design at peak stress point of frame for added strength and stability
- 14-gauge cross braces
- 16-gauge hanging rods
- Heavy duty caster features 325lb. weight capacity and measures 4" x 1 1/4"
- Swivel wheels for easy gliding
- Chair capacity 84 standard folding chairs
- Dark Brown Powder Coated Steel
- Optional EXT-8 Extension Bar Available

84-60 / CHAIR CADDY

DIMENSIONS: OVERALL: 67"W X 33 1/4"D X 70"H - WEIGHT 105 LBS.

- 7-gauge main frame features channeled steel with tube in tube design at peak stress point of frame for added strength and stability
- 14-gauge cross braces
- 16-gauge hanging rods
- Heavy-duty caster features 325lb. weight capacity and measures 4" x 1 1/4"
- Swivel wheels for easy gliding
- Capacity to hold 60-70 coats when two coat rods are in place. Coat rods can be removed to store up to 84 Folding Chairs
- Dark Brown Powder Coated Steel

MODEL 84/42-60-8 / CHAIR-TABLE-COAT CADDY

DIMENSIONS: OVERALL: 67"W X 33 1/4"D X 70"H - WEIGHTS 122LBS.

- 7-gauge main frame features channeled steel with tube in tube design at peak stress point of frame for added strength and stability
- 14-gauge cross braces
- 16-gauge hanging rods
- Heavy-duty caster features 325lb. weight capacity and measures 4" x 1 1/4"
- Swivel wheels for easy gliding
- Interchangeable middle bar; one for hanging-chairs or straight bar for folding tables
- Two coat rods
- Dark Brown Powder Coated Steel

DY-35 & DY-50 / FOLDING CHAIR TRUCK

DIMENSIONS: DY-35 OVERALL: 38 1/2"H X 19 1/4"W X 81"D
DY-50 OVERALL: 38 1/2"H X 19 1/4"W X 106"D
INSIDE WIDTH: 19"W WITH A 2" LIP TO ACCOMMODATE CHAIRS 15 1/4"W - 19"W

- Optional Understage Conversion Kit to store chairs in a horizontal fashion underneath stages 25.5" Height capacity with chairs loaded
- 7-gauge steel bed
- Heavy-duty caster features 275lb. weight capacity; 2 swivel and 2 stationary
- DY-50 has extra swivel caster in the middle for support
- 3 tubular handles-one at each end and one in the middle
- Dark Brown Powder Coated Steel

DY81 / CHAIR TRUCK

DIMENSIONS: OVERALL: 3.5"H X 22 3/4"W X 23 1/2"D WITH A 5.25"W BED

- 16-gauge, 1.6MM steel
- Holds up to 10 8100 or 9000 Series Stack Chairs
- Black Powder Coated Steel
- Shipping Class 85
- Hard Rubber casters 4" x 1 1/4"
- 265 lbs. weight capacity

DY82 / DOLLY FOR 8200 SERIES CHAIRS

DIMENSIONS: OVERALL: 38"H X 22 3/4"W X 35"L

- 16-gauge, 3/4" round handles
- 17-gauge, 7/8" square frame
- Stacks up to 18 series 8200 chairs
- 4 casters; Two swivel, two non-swivel. 4" x 1 1/4"
- Ship weight: 24 lbs
- Chrome-plated steel
- 330 lbs. weight capacity

DY85 / CHAIR DOLLY

DIMENSIONS: OVERALL: 26"H X 20 1/2"W X 21"D

- Constructed of 11-gauge steel
- Chairs load at an angle to maximize stack ability
- Stacks up to 40 of the 8500 Series
- Black Powder Coated Steel
- Hard rubber casters: 4 x 1 1/3"
- Fully loaded: 20.5"W x 35"D x 77"H
- 650 lbs. weight capacity

DY86 / DOLLY FOR 8600 SERIES CHAIRS

DIMENSIONS: OVERALL: 26"H X 21"W X 21"D

- 11-gauge, 1" x 2" angled steel
- Stacks up to 20 series 8600 chairs (19"H x 36"D x 57"H)
- Ship weight: 37 lbs
- Nylon casters 2 3/4" x 1 1/5"
- 330 lbs. weight capacity

DY87 / DOLLY FOR 8700 SERIES CHAIRS

DIMENSIONS: OVERALL: 26"H X 18 1/2"W X 28"L

- 18-gauge steel frame
- Stacks up to 35 series 8700 chairs (20 1/4"W X 35"D X 75 1/2"H)
- 4 PVC swivel locking casters; 154lb. per caster weight capacity; 616 lb. total weight capacity
- Ship weight: 15 lbs
- Grey powder coated finish

DY87B / DOLLY FOR 8700B SERIES CHAIRS

DIMENSIONS: OVERALL: 26"H x 18 1/2"W x 28"L

- 18-gauge 7/8" tubing
- Stacks up to 24 series 8700B/8800B stools (84"H)
- Max stack for 80" doorway - 22 units
- Product weight: 18 lbs
- Carton weight: 23 lbs
- Carton dimensions: 19"W x 35"D x 51"H
- 4 PVC Swivel Locking Casters: 154 lbs. per caster weight capacity and 616 lbs. total weight capacity

DY700/800 / CHAIR DOLLY

DIMENSIONS: OVERALL: 35"H X 40"W X 19"D

- Constructed of 11-gauge steel
- 7/8" round tubular handle and 4" polyolefin casters; 2 swivel
- Stacks up to 36 of the 800 Series
- Optional strap to tie down chairs during transport and storage
- Black Powder Coated Steel
- Hard rubber casters: 4 x 1 1/4"
- 82" H when fully loaded with 36 chairs

DY1100 / CHAIR DOLLY

DIMENSIONS: OVERALL: 39"H X 19"W X 46 1/2"D

- 11-gauge powder-coated steel frame
- 2 swivel and 2 fixed 4" casters
- Storage and transport for 1100 Series Folding Chair
- Holds up to 26 chairs
- Black Powder Coated Steel

NPS Product Specifications

- Nylon casters: 4 x 1 1/4"
- Loaded height: 80"

DY1400 / DOLLY FOR AIRFLEX SERIES CHAIRS

DIMENSIONS: OVERALL: 38 1/2"H X 19 1/4"W X 109 1/2"D

- Stacks 54 AirFlex chairs.
- Heavy-duty caster features 275lb. weight capacity; 2 swivel and 2 stationary
- Extra swivel caster in the middle for support
- 3 tubular handles-one at each end and one in the middle
- Dark Brown Powder Coated Steel

DY-9000 / BANQUET STACK CHAIR DOLLY

DIMENSIONS: OVERALL: 52"H X 18"W X 34"D

- 1" Round Tubular 16-gauge steel
- 8"D x 2"W Polyolefin wheels
- Stacks up to 12 Series 9000 and 8100 Series chairs
- Ship weight: 26 lbs
- Dark Brown Powder Coated Steel

DY-60R • DYMU / TABLE TRUCK

DIMENSIONS: OVERALL: 31 1/4"H X 27 3/4"W X 47 1/2"L FRONT HANDLE: 27 3/4"W X 15"D

- Transportation and vertical storage of 48" & 60" round, plastic or laminate tables
- Easy handling with 4 casters: 2 swivel and 2 stationary
- 2 tubular handles, 1 front handle
- Constructed of brown powder-coated steel
- Distance between wood slats: 27 3/4"
- Distance from frame to top of handle: 25 1/2"
- Fully loaded height: 65"H
- Casters are 4" x 1 1/4"; made of Hard Rubber with weight capacity of 165 lbs. each / 660 lbs. total

DY-71R / TABLE TRUCK

DIMENSIONS: TOTAL FOOTPRINT: 40 1/2"H X 28"W X 61 1/2"D FRONT HANDLE: 27 3/4"W X 15"D

- Transportation and vertical storage of 71" round, plastic or laminate tables
- Easy handling with 4 casters: 2 swivel and 2 stationary
- 2 tubular handles, 1 front handle
- Constructed of brown powder-coated steel
- Distance between wood slats: 27 3/4"
- Fully loaded height: 76"
- Casters are 4" x 1 1/4"; made of Hard Rubber with a weight capacity of 165 lbs. each / 660 lbs. total

DY-3072 & DY-3096 / FOLDING TABLE DOLLY

DIMENSIONS: DY3072 OVERALL: 43"H X 31"W X 74"L DY3096 OVERALL: 43"H X 31"W X 90.25"L

- 1" O.D. steel handle provides stability and ease of handling
- Holds 4', 5', 6', or 8' tables
- Laid flat, stacks up to 12 tables high
- Rolls on 4 casters: 2 swivel and 2 stationary
- Dark Brown Powder Coated Steel
- Casters: 4 x 1 1/4" with Weight Capacity of 165 lbs. each / 660 lbs. total (DY3072 - Hard Rubber, DY3096 - Hard Rubber)

TAD DOLLY / FOLDING TABLE DOLLY

DIMENSIONS: 44.5"H X 38"W X 30"L

- 1" square 14-gauge tubular frame
- 7/8" O.D. Steel Handle (18-Gauge) provides stability and ease of handling
- May be used for 4', 5', 6', or 8' Tables
- Rolls On 4 swivel Casters: 2 locking and two non-locking
- Casters Are 5" X 1 1/4"; Hard rubber
- Textured black Powder-Coated Steel
- Plastic coated table support frames
- Total Weight Capacity: 1,000 Lbs.

Stools

6200 SERIES / HEAVY DUTY STEEL STOOLS

- 18"H, 24"H or 30"H sizes fixed and adjustable with an optional backrest
- 7/8" O.D. 18-gauge steel tubing
- Seat is a full 14" diameter with 11 1/2" diameter masonite board is recessed into the pan with 8 rivets and will not chip or crack
- Foot rings, 3/4" O.D. are welded to each leg by 4 contact points at each leg for added rigidity
- Optional backrest; 6"H x 12"W, adjusts up/down and forward/back
- Optional height adjustable legs; adjust in 1" increments up to eight additional inches
- All sizes available in black and grey colors

6300 SERIES / HEAVY DUTY SQUARE SEAT STEEL STOOLS

- 18"H, 24"H or 30"H sizes fixed and adjustable with an optional backrest
- 7/8" O.D. 18-gauge steel tubing
- Features a 14.5" Wx15"D contoured hardboard seat with 16 rivets
- Foot rings, 5/8" O.D. are welded to each leg by 4 contact points at each leg for added rigidity
- Optional backrest; 6"H x 12"W, adjusts up/down and forward/back
- Optional height adjustable legs; adjust in 1" increments up to eight additional inches

6400 SERIES / HEAVY DUTY STEEL STOOLS WITH VINYL PADDING

- 18"H, 24"H or 30"H sizes fixed and adjustable with an optional backrest
- 7/8" O.D. 18-gauge steel tubing with fixed or adjustable legs
- Seat is 14" diameter with an 11 1/2" diameter 1/2" vinyl padding riveted through the steel seat pan
- Foot rings, 3/4" O.D. are welded to each leg by 4 contact points at each leg for added rigidity
- Optional vinyl padded backrest; 6"H and 12"W and adjusts up/down and forward/back
- Optional height adjustable legs; adjust in 1" increments up to eight additional inches
- MDF seat board upgraded from 3mm to 4.75mm, with rivet heads fully embedded
- All sizes available in black and grey colors

6524H & 6524HB / ADJUSTABLE PREMIUM SWIVEL STOOL W/ BACKREST-GRAY

- Height adjustable from 24 - 32"
- 3/4" O.D. 16-gauge steel tubing
- Swivel seat 360 degrees
- Foot rings, 5/8" O.D. are welded to each leg by 4 contact points at each leg for added rigidity
- MDF seat board upgraded from 3mm to 4.75mm, with rivet heads fully embedded

6600 SERIES ELEPHANT Z-STOOL / HEAVY DUTY CHROME PLATED STOOLS WITH BLOW MOLDED SEAT

- 18"H, 22"H or 24"H sizes fixed with an optional backrest
- 14-gauge chrome-plated eye-shaped tubular steel frame
- Ergonomic blow molded contoured seat providing maximum air comfort
- U-shaped sled base legs with specially designed glides to be used on multiple floor types (including VCT tiles)
- Glides are permanently attached with embedded Thermoplastic Polyurethane (TPU) and provide quiet and smooth gliding on all floor types
- Nests on tabletops for easy cleanup and storage
- Optional blow molded contoured backrest
- Foot rests made of 17-gauge chrome eye-shaped tubular steel (available on 22"H and 24"H models)
- Available Colors: ■ Black

6722HB/6716HB KANGAROO STOOL / POLYURETHANE ADJUSTABLE STOOL

- Also available with arms as model 6722HB-A and 6716HB-A
- Heavy duty 1-1/4 inch thick Polyurethane seat with waterfall edge
- Polyurethane material is resistant to chemicals & punctures, & cleans easily
- 6722 Features 10" of pneumatic height adjustment from 22" - 32"
- 6716 Features 5" of pneumatic height adjustment from 16" - 21"
- Swivels 360 degrees for unlimited functionality
- Integrated under seat spring system allows for control of backrest tilt degree with a turn of a knob
- Footrest adjusts 12 inches up or down for comfort
- Built on five 2 inch industrial grade caster wheels for portability or install

NPS Product Specifications

- included mushroom glides for use in a stable environment
- Promotes natural sitting posture with lumbar support
- Convenient backrest handhold for maneuverability
- Material: Seat & Back: Polyurethane. Legs: Plastic. Footrest: Chrome.
- Seat height: 22 – 32 inches. Overall height: 38-48 inches
- Seat height: 22 – 32 inches. Overall height: 38-48 inches
- ANSI BIFMA tested.
- Green & LEED certification: MAS.
- Weight: 16lbs
- Ship via: UPS.
- Carton dimensions 24W" x 24L" x 12H" · Carton weight: 26 lbs.
- Available Colors: ■ Black

6800 DESIGNER STOOL

DIMENSIONS: OVERALL: 14½"W X 14½"D X 18"-25"H

- 1" diameter 18 gauge steel powdercoated tubing
- 113-3/4" diameter 18 gauge steel powdercoated seatpan with a variety of colored polypropylene surface
- 13-3/4" diameter 1" thick solid hardwood seat with a clear lacquer paint finishing
- Seat adjustable from 18" – 25" using the swivel mechanism
- 360° turning capability
- Metal center sleeve to conceal adjustable height pole
- Built in 4" height footrest with a 15" diameter
- Non-marring glides
- Seat is attached using a unique pressure connection mechanism
- The wooden seat is 1" thick hardwood with a clear lacquered paint finishing with either a Metallic Grey or a Black base.
- The stool frame is available in Metallic Grey and Black
- 20" Cross Leg Distance
- Product weight- 12.6 lbs.
- Carton weight- 16.5 lbs.
- Carton Dimensions- 15" x 17" x 21"
- Available colors Frames: ■ Metallic Grey ■ Black
- Seatpan: ■ Metallic Grey ■ Wood
- Seat Surface: ■ Blueberry ■ Persian Blue ■ Black ■ Burgundy
- Soft Seating: 3" H top in ■ Black ■ Charcoal ■ Cobalt Blue

8700B & 8800B CAFETORIUM BARSTOOL

DIMENSIONS: OVERALL: 44 5/8"H X 21 1/3"W X 21 5/8"D

- 18-Gauge 7/8" Tubing
- Solid 1" Plastic Stacking Glides
- Back Design Provides Ergonomic Support
- Cafetorium Chair in Bar/Café Height
- 300 lb Weight Capacity
- Available Colors Seat: ■ Black
- Available Colors Back: ■ Black
- Available Colors Frame: ■ Chrome

Tables

BT2448 / HEAVY DUTY FOLDING TABLE

- Speckled Grey Top/ Grey Hammertone Frame
- Available in 48" L rectangular size
- 1.75 in. Tabletop Thickness
- Plastic tabletop is heat-resistant up to 212° F
- Non-bowing eggshell structure
- Powder-coated 17-gauge steel frame
- Lightly Textured Surface Resist Scratching Yet Smooth Enough To Write On
- Extra Stable Gravity Lock
- 400 lbs. Weight Capacity when evenly distributed

BT3060 / BT3072 / BT3096 / LIGHTWEIGHT BLOW MOLDED FOLDING TABLES

- Available in 3 rectangular sizes – 60", 72", 96"
- 1 3/4" thick top for the BT3060 & BT3072
- 2" thick top for the BT3096
- Lightly spotted grey top w/ grey textured powder coated wishbone shaped legs.
- 17-gauge strength frame; 18-gauge legs
- 1,000lb. weight capacity on BT3060, BT3072, equally distributed weight

- 800lb. weight capacity on BT3096, equally distributed weight
- Stack up to 12 high on DY3072 and DY3096
- Can withstand heat up to 212 degrees Fahrenheit
- Gravity slide lock or snap lock, for extra stability
- Lightly textured surface to resist scratching yet smooth enough to write on

BT3072-20 / LIGHTWEIGHT BLOW MOLDED FOLDING TABLES

- 1 3/4" thick top
- Charcoal slate top w/ silver-tone frame.
- 17-gauge strength frame; 18-gauge legs
- 1,000lb. weight capacity, equally distributed weight
- Stack up to 12 high on DY3072 and DY3096
- Can withstand heat up to 212 degrees Fahrenheit
- Gravity slide lock or snap lock, for extra stability
- Lightly textured surface to resist scratching yet smooth enough to write on

BT3636 / SQUARE BLOW-MOLDED PLASTIC FOLDING TABLE

- Lightly textured surface to resist scratching yet smooth enough to write on
- Square shape
- 1 ¾" thick top
- Lightly spotted grey top w/ grey textured powder coated straight shaped legs on a square tabletop
- Tested and passed 500 lbs. distributed weight.
- Can withstand heat up to 212 degrees Fahrenheit
- Gravity slide lock or snap lock, for extra stability
- 19-Gauge Strength Frame And 19-Gauge Legs
- Attractive Arched tube leg connectors for added strength
- 10 Year Warranty
- Weighs 23 lbs.

BT48R/BT60R/BT71R / LIGHTWEIGHT BLOW MOLDED ROUND FOLDING TABLES

- Available in 3 round sizes - 48", 60", 71"
- 2" thick top
- Lightly spotted grey top w/ grey textured powder coated straight legs
- BT60R: 17-gauge strength frame; 18-gauge legs
- BT48R & BT71R: 19-gauge strength frame and legs
- 1,000lb. weight capacity on BT60R
- 700lb. weight capacity on BT48R & BT71R
- Holds up to 10 tables in DY60R and DY71R
- Can withstand heat up to 212 degrees Fahrenheit
- Gravity slide lock or snap lock, for extra stability
- Lightly textured surface to resist scratching yet smooth enough to write on

BTA-3072 / ALL AMERICAN COLORS BLOW MOLDED FOLDING TABLES

- Available in 72"L rectangular size
- 1 3/4" thick top
- BTA-3072 comes in primary colors Red or Blue & is height adjustable from 22"-28.5"H
- 17-gauge strength frame
- 1,000lb. weight capacity
- Stack up to 12 high on DY3072 and DY3096
- Can withstand heat up to 212 degrees Fahrenheit
- Gravity slide lock or snap lock, for extra stability
- Lightly textured surface to resist scratching yet smooth enough to write on
- Available colors: ■ Red ■ Blue

BT1860/BT1872/BT1896 / LIGHTWEIGHT FOLDING SEMINAR TABLES

- Available in 3 sizes; 60"L, 72"L & 96"L by 18"W
- 2-inch thick top
- Lightweight for easy set-up and transport
- 700lb. weight capacity
- Lightly spotted gray top w/ gray textured powder coated legs
- BT1860 & BT1872: 18-gauge strength frame
- BT1896: 17-gauge strength frame
- 16-gauge cantilevered comfort legs set 11" from back of table; no more banged up knees!
- Stack up to 12 high on DY3072 and DY3096
- Can withstand heat up to 212 degrees Fahrenheit
- Lightly textured surface to resist scratching yet smooth enough to write on

NPS Product Specifications

BPFT-2460 / PLASTIC FLIP-N-STORE TABLES

- Tops are made of lightweight HDPE blow molded plastic.
- Tops are furnished with two grommet holes for wire management.
- Equipped with dual levers, allowing for easy tabletop folding
- Tables nest together for space-saving storage.
- Frame and legs are made of grey hammer-tone powdercoated steel and includes a perforated steel modesty panel for an attractive design.
- Modesty panel features a built-in cable channel to conceal wires.
- Tables are equipped with four 2" casters (two locking) making them easy to roll.
- Tables tested to support up to 700 lbs. and are guaranteed for ten years.
- MAS certified Green®
- Tables are lightweight weighing only 46 lbs. and are easy to assemble.
- Opened dimensions are 60"L x 24"W x 29½"H
- Folded dimensions are 43½"H x 60"L x 24½"W
- Tabletop thickness: 1¾"
- Gauge of steel: 16 gauge
- Carton dimensions are 60 3/4"L x 24 3/4" W x 4 3/4" D. Carton weight 50 lbs.
- Ships with UPS oversize or by truck at class 125.
- Available Colors: ■ Grey ■ Charcoal

BPFT-2472 / PLASTIC FLIP-N-STORE TABLES

- Tops are made of lightweight HDPE blow molded plastic.
- Tops are furnished with two grommet holes for wire management.
- Equipped with dual levers, allowing for easy tabletop folding
- Tables nest together for space-saving storage.
- Frame and legs are made of grey hammer-tone powdercoated steel and includes a perforated steel modesty panel for an attractive design.
- Modesty panel features a built-in cable channel to conceal wires.
- Tables are equipped with four 2" casters (two locking) making them easy to roll.
- Tables tested to support up to 700 lbs. and are guaranteed for ten years.
- MAS certified Green®
- Tables are lightweight weighing only 52 lbs. and are easy to assemble.
- Opened dimensions are 72"L x 24"W x 29½"H
- Folded dimensions are 43½"H x 72"L x 24½"W
- Tabletop thickness: 1¾"
- Gauge of steel: 16 gauge
- Carton dimensions are 72 ¾"L x 24 ¾" W x 4 ¾" D. Carton weight 56.
- Ships with UPS oversize or by truck at class 125.
- Available Colors: ■ Grey ■ Charcoal

BMFIH3072 / PLASTIC FOLD-IN-HALF TABLES

- Open dimensions 71.8"L x 30"W x 29.5"H
- Folded dimensions 36"L x 30"W x 3.75"D
- Frame color Speckled grey
- Frame specifications- 19 gauge powder coated steel
- Leg specifications- 1 1/8 round 19 gauge tubing
- 700 lb. weight capacity
- Tabletop specifications - 1.5" High-Density Polyethylene (HDPE)
- Tabletop color - Grey
- Table weight 33 lbs.
- Carton weight 37 lbs.
- Carton Dimensions - 37" x 31" x 4.75"
- Ships with UPS
- Ships FOB Memphis TN
- 700lb. distributed weight capacity
- BIFMA tested
- Shipping class 70

MAX SEATING™ FOLDING TABLES

- 4 Tabletop Options:
 - .75" thick premium plywood tabletop with 3mm PVC edge
 - .75" thick premium plywood tabletop with Protect Edge
 - .75" thick Particleboard with T-molding
 - .75" thick premium plywood tabletop with T-molding
- Clear acrylic tabletop surface (on plywood core only) or HPL.
- 16 gauge C-channel frame design with textured black powdercoating
- 16 gauge frame joining plates
- Legs are made from 14 gauge 1.25" square leg tubing

- Legs are positioned at table corners to enable Max Seating™
- 2-point welded leg brace
- Auto-Engage locking mechanism
- Lock requires manual disengagement
- Proprietary leg clips
- 14 gauge Stability-Boost leg brackets
- Nylon stacking corner with standoff
- 16 gauge steel apron joining plates
- High-impact non-marring spring steel flower glides
- Folding legs and Auto-Engage lock tested to exceed 7,000 cycles

HDT HEAVY-DUTY TABLES

- Comes in 6 tabletop options:
 - .75" Standard high pressure laminate top
 - 1.25" Supreme high pressure laminate top
 - 1.25" Whiteboard top
 - 1" Chem-res top
 - .75" Phenolic top
 - 1.75" Butcherblock top
- 50 frame sizes available – Any frame combination using the following width/lengths:
18", 24", 30", 36", 42", 48", 54", 60", 72", 84" and 96".
- 16 gauge steel frame
- 11 gauge steel brackets
- Legs are built with 14 gauge thick 1 ½" square tubing
- Leg base is fastened to tabletop with 4 heavy-duty screws and gets inserted into the frame using a strong welded hangar bolt
- Legs connect to the frame corner brackets with industrial-grade nylon-insert lock nuts
- Adjustable and fixed height leg options
- Adjustable legs adjust in 1" increments, and are locked firmly in place with 2 k-9 external tooth lock washers and heavy-duty tamper-free hex screws.
- Fixed height leg is 28.5"H (without tabletop)
- Adjustable legs are 21.25"-36.25"H (without tabletop)
- Legs come standard with simple-adjust glides that can add an additional .75"H, and have a caster option.
- 2 peg boards, and a set of 50 variety pegs included in optional peg board set
- Peg boards available for 24" and 30" wide tables
- Peg boards are 16 gauge steel, and pegs are 7 gauge steel
- 4 13-gauge steel gussets and 4 3" heavy duty casters included in optional caster/gusset kit
- Gussets are included with all tables 31" & wider, and 73" and longer, and are recommended when using any table above 30" high
- All parts available with Textured black and Soft Grey powdercoating

HIGH PRESSURE LAMINATE TOP:

- Resistant to:

1	Distilled water	8	Fresh tea
2	50:50 Ethyl alcohol	9	Catsup
3	Acetone	10	Yellow mustard
4	Household ammonia	11	10% Povidone iodine
5	10% Citric acid	12	Black Permanent Marker
6	Vegetable oil	13	#2 pencil
7	Fresh coffee	14	Wax crayon
		15	Black paste shoe polish

Chem-Res Top:

- Black, Chem-Res high-pressure laminate top on a 1" thick core. Resistant to 13 chemicals:

NPS Product Specifications

NO.	CHEMICAL COMPOUND	CHEMICAL NAME	STAIN GRADE	TEST METHODS
1	NaOH (40%)	Sodium Hydroxide	0	NEMA LD3-2005
2	H ₂ O ₂ (3%)	Hydrogen Peroxide	0	NEMA LD3
3	HCl (37%)	Hydrochloric Acid	0	NEMA LD3
4	CH ₃ COOH (99%)	Acetic Acid	0	NEMA LD3
5	H ₂ SO ₄ (98%)	Vitriol	0	NEMA LD3
6	HNO ₃ (65%)	Nitric Acid	0	NEMA LD3
7	H ₃ PO ₄ (85%)	Phosphoric Acid	0	NEMA LD3
8	HF (48%)	Hydrofluoric Acid	0	NEMA LD3
9	Formaldehyde (37%)	Formallin	0	NEMA LD3
10	NH ₄ OH (25%)	Ammonia	0	NEMA LD3
11	Phenol	Phenol	0	NEMA LD3 - 2000
12	Na ₂ S	Saturated Sodium Sulfide	0	NEMA LD3 - 2000
13	CCl ₄	Carbon Tetrachloride	0	NEMA LD3 - 2000

Phenolic Top:

- Black, solid 3/4 phenolic resin composite thermo-fused under heat and pressure to form a solid black chemical resistant panel.
- Highly impervious to most chemicals, acids, corrosions, stains and moisture.
- Meant for tough use, comparable to Epoxy Resin tops, Emission free, UV Resistant
- Solid phenolic throughout allowing for easy care and maintenance
- Resistant to:

CHEMICAL NAME	CHEMICAL NAME
Acetate, Amyl	Hydrofluoric Acid, 48%
Acetate, Ethyl	Hydrogen Peroxide
Acetic Acid 98%	Iodine Tincture of
Acetone	Methyl Ethyl Ketone
Acid Dichromate, 5%	Methylene Chloride
Alcohol, Butyl	Mono Chlorobenzene
Alcohol, Ethyl	Naphthalene
Alcohol, Methyl	Nitric Acid, 30%
Ammonium Hydroxide	Phenol, 90%
Benzene	Phosphoric Acid, 85%
Carbon Tetrachloride	Silver Nitrate Saturated
Chloroform	Sodium Hydroxide 10%
Chromic Acid, 60%	Sodium Hydroxide 20%
Cresol	Sodium Hydroxide 40%
Dichloro Acetic Acid	Sulfuric Acid 33%
Dimethylformamide	Sulfuric & Nitric Acids
Dixane	Sulfuric & Nitric Acids mix 77%, 70%
Ethyl Ether	Zinc Chloride Saturated
Formaldehyde	
Furfural	

SLT1 / SLT2

SCIENCE LAB TABLE WOOD LEGS SERIES

- Tops are available in Phenolic, Chem-res, High Pressure Laminate, Whiteboard, Epoxy and Trespa
- Patent Pending Personal Lab Tables available
- 30"H & 36"H tables available in 24", 30" and 42" width
- 24"W table available in 30", 48", 54", 60" and 72" lengths
- 30"W table available in 60" and 72" lengths
- 42"W table available in 60" and 72" lengths
- Solid ash legs and apron
- Optional book compartments measuring 14 1/4"L x 12 3/4"D x 4"H
- Legs attach with metal on metal double bolt through assembly on 13-gauge steel corner braces
- Legs come standard with adjustable glides for accurate leveling and rubber liquid protecting boots
- Set of 4 3" heavy duty casters available for all tables, and includes a stretcher and braces for added support.
- Stretcher and braces are included with all tables 31" & wider, and 73" and longer

SLT3 / SLT7 / SLT8 / SLT9

SCIENCE LAB TABLE STEEL LEG SERIES

- Tops are available in Phenolic, Chem-res, High Pressure Laminate, Whiteboard, Epoxy and Trespa
- Patent Pending Personal Lab Tables available
- 16 gauge steel frame

- 11 gauge steel brackets
 - Legs are built with 14 gauge thick 1 1/2" square tubing
 - Leg base is fastened to tabletop with 4 heavy-duty screws and gets inserted into the frame using a strong welded hangar bolt
 - Legs connect to the frame corner brackets with industrial-grade nylon-insert lock nuts
 - Adjustable and fixed height leg options
 - Adjustable legs adjust in 1" increments, and are locked firmly in place with 2 k-9 external tooth lock washers and heavy-duty tamper-free hex screws.
 - Fixed height leg is 28.5"H (without tabletop)
 - Adjustable legs are 21.25"-36.25"H (without tabletop)
 - Legs come standard with simple-adjust glides that can add an additional .75"H, and have a caster option.
 - 4 13-gauge steel gussets and 4 3" heavy duty casters included in optional caster/gusset kit
 - Gussets are included with all tables 31" & wider, and 73" and longer, and are recommended when using any table above 30" high
 - All parts available with Textured black and Soft Grey powdercoating
- SEE HEAVY DUTY TABLE SECTION FOR ALL AVAILABLE OPTIONS

SLT4-2448 / SLT4-2454 / SLT4-2460 / SLT4-2472 / SLT4-3060 / SLT5-2448 / SLT5-2454 / SLT5-2460 / SLT5-2472 / SLT5-3060

SIGNATURE SCIENCE TABLES WITH ADJUSTABLE HEIGHT LEGS SERIES

- Tops are available in Phenolic, Chem-Res, or High Pressure Laminate
- Available in 24" & 30" width
- 24"W table available in 48", 54", 60" and 72" lengths
- 30"W table available in 60" length
- Solid ash apron and steel legs in your choice of Laminated Oak or Powdercoated Black
- Optional book compartments measuring 14 1/4"L x 12 3/4"D x 4"H
- Aprons are connected together with four semi-round 14 gauge stainless steel metal brackets
- Legs attach with six 18mm screws
- Table adjusts in 3/4" increments from 27"-42"H (with spacer provided)
- Optional 4 Double wheel locking casters available measuring 2 3/8" x 2 3/8" and are adjustable up to 1/2". Material: Plastic. Color: Black

SLT6-2448 / SLT6-2454 / SLT6-2460 / SLT6-2472 / SLT6-3060

SCIENCE LAB TABLE DESIGNER LEGS SERIES

- Available table tops: Phenolic, Chem-Res, High Pressure Laminate, Butcherblock, Whiteboard
- Patented designer legs adjust in 3/4" increments from 27"-42"H (with spacer provided).
- Legs come standard with simple-adjust glides. Optional casters available.
- 11 gauge leg-bases are fastened to the tabletop with 6 heavy-duty screws
- Under-table hat support provides 500lbs. weight capacity
- Adjustable glides for accurate leveling

MSC2436 / MOBILE SCIENCE CABINET

- 270 degree wrap-around hinges
- Fully oak veneered plywood core cabinet and shelf
- 1-1/4" thick high pressure laminated surface compliant with NEMA standard testing
- 4 heavy duty 4 inch swivel locking casters
- Adjustable height shelf
- Door Lock
- Cabinet Color - Light Oak Veneer
- Tabletop Color - Black HPL
- Product Dimensions - 24"W x 36"L x 36"H
- Product weight 103 lbs.
- Carton weight - 110 lbs.
- Carton Dimensions - 43" x 34" x 8"
- Ships UPS from - NJ
- Freight class 100

NPS Product Specifications

MOBILE TABLES

MOBILE FIXED BENCH TABLE

GENERAL Folding mobile cafeteria table with attached benches shall have a top surface measuring 30" wide and bench surface of 10" wide. The top surface shall be 29" high and bench surface shall be 17" high when opened for use. The overall top length shall be 12'1", 10'1", or 8'1". The overall width of the unit shall be 56". When folded the table shall fit through a 36" wide doorway.

ENTRANCES Each bench unit shall have six walk-in entry points. Benches shall be attached to the table structure in a manner that does not significantly obstruct the user from entering from either end or between the benches. The center leg bench support shall be an offset double tube design thus eliminating a trip point during entry. End leg metal components located near the floor, where feet may come into contact with them shall be chrome plated. All other metal frame components should be epoxy powder coated or chrome option.

LOCKING - OPENING A gravity lock shall automatically lock the table into the open position. The lock is disengaged manually, capable of operating from both sides of the table. The table design shall feature a midway position lock to secure the unit in a partially folded position for ease of movement during floor cleaning and to prevent finger/hand pinching. The lock rod shall be 7/16" diameter and chrome plated to resist wear.

LOCKING - FOLDING A storage lock shall automatically lock the table in the folded storage position. The lock is disengaged manually, capable of operating from both sides of the table within easy reach. Easy opening and closing via a perfectly balanced torsion bar system. Each unit will include 4, 3, or 2 torsion bars determined by table size and core material.

TABLE AND BENCH TOPS Table and bench tops shall be surfaced with high pressure laminate bonded to a ¾" thick MDF core, sealed underneath with a phenolic backer sheet. Bench shall be surfaced with high pressure laminate bonded to a ¾" thick MDF core, sealed underneath with a phenolic backer sheet. Edge of the tops and benches shall be sealed with ProtectEdge, a polyurethane epoxy resin, chemically bound to the edge of the laminate, core and phenolic backing sheet.

Optional Plywood core with ProtectEdge: Table and bench tops shall be surfaced with high pressure laminate bonded to a ¾" thick AC grade plywood core, sealed underneath with a phenolic backer sheet. Edge of the tops and benches shall be sealed with a polyurethane epoxy resin, ProtectEdge, chemically bound to the edge of the laminate, core and backing sheet.

Optional Plywood Core with Vinyl T-molding: Table and bench tops shall be surfaced with high pressure laminate bonded to a ¾" thick AC grade plywood core, sealed underneath with a poly resin backer sheet. Edge of the tops and benches shall be banded with vinyl T-molding, secured by staples to the tops underside approximately every 10".

Optional Particleboard Core with Vinyl T-molding: Table and bench tops shall be surfaced with high pressure laminate bonded to a ¾" thick 47 lb. particleboard core, sealed underneath with a poly resin backer sheet. Edge of the tops and benches shall be banded with vinyl T-molding, secured by staples to the tops underside approximately every 10".

TABLE TOP SUPPORT Each top shall be supported by two 1 7/8" deep, 14-gauge steel aprons. Apron shall contain no holes greater than ½" diameter. Aprons shall be capped at the ends with riveted plastic protectors. Each top shall be supported across the width of the top in at least two places.

LEG ASSEMBLIES Leg assemblies shall have vertical tubes supporting the benches and shall be constructed of 1½" diameter, 14-gauge steel tubing with 11-gauge tubing used on the base of the end leg assemblies. Caster lift-off shall be constructed of 14-gauge chrome plated rectangular steel. All other tubular components shall be 1.05" diameter, 14-gauge steel tubing, or structural members of equal or greater strength. Non-marring glides are glass infused nylon that is captured inside the leg tube with spring clips to stay in place.

CASTERS Casters shall be heavy-duty, double ball bearing type with a minimum rated load capacity of 275 lbs. each. Casters should have hard rubber non-marking wheels 4" diameter x 1½" wide.

SAFETY REQUIREMENTS Bench units shall be safety tested and listed by Underwriter's Laboratories, Inc. Bench units must display UL labels with valid UL file number. When bench unit is opened for use, all casters shall lift off the ground automatically to minimize table movement while in use. Casters that protrude past the end of the bench unit when opened for use, are prohibited to prevent tripping hazard. Bench units shall have no moving parts that can pinch, cut or pierce the operator's hand while the table is being folded up and down. There shall be at least a 1" gap between the inner leaves of the table tops to prevent pinched fingers.

WARRANTY MTFB units covered by 15-year warranty.

MOBILE STOOL TABLE

GENERAL Folding mobile cafeteria table with attached stools shall have a top surface measuring 30" wide. The top surface shall be 29" high and bench surface shall be 17" high when opened for use. The overall top length shall be 12'1", 10'1", or 8'1". Leg assemblies shall be chrome plated or epoxy powder coated. When folded the table shall fit through a 36" wide doorway.

ENTRANCES Each stool position shall have its own entrance clear of obstructions when entering the unit to sit down. Stool units having support members running across the entrance area are not acceptable.

LOCKING - OPENING A gravity lock shall automatically lock the table in the open position. The lock is disengaged manually, capable of operating from both sides of the table. The table design shall feature a midway position lock to secure the unit in a partially folded position for ease of movement during floor cleaning and to prevent finger or hand pinching. The lock rod shall be 7/16" diameter and chrome plated to resist wear.

LOCKING - FOLDING A storage lock shall automatically lock the table in the folded storage position. The lock is disengaged manually, capable of operating from both sides of the table within easy reach. Easy opening and closing via a perfectly balanced torsion bar system. Each unit will include 5, 4, 3, or 2 torsion bars determined by table size and core material.

TABLE TOPS Table tops shall be surfaced with high pressure laminate bonded to a ¾" thick MDF core, sealed underneath with a phenolic backer sheet. Edge of the tops shall be sealed with ProtectEdge, a polyurethane epoxy resin, chemically bound to the edge of the laminate, core and phenolic backing sheet.

Optional Plywood core with ProtectEdge: Table tops shall be surfaced with high pressure laminate bonded to a ¾" thick AC grade plywood core, sealed underneath with a phenolic backer sheet. Edge of the top shall be sealed with a polyurethane epoxy resin, ProtectEdge, chemically bound to the edge of the laminate, core and phenolic backing sheet.

Optional Plywood Core with Vinyl T-molding: Table tops shall be surfaced with high pressure laminate bonded to a ¾" thick AC grade plywood core, sealed underneath with a poly resin backer sheet. Edge of the top shall be banded with vinyl T-molding, secured by staples to the tops underside approximately every 10". **Optional Particleboard Core with Vinyl T-molding:** Table tops shall be surfaced with high pressure laminate bonded to a ¾" thick 47 lb. particleboard core, sealed underneath with a poly resin backer sheet. Edge of the top shall be banded with vinyl T-molding, secured by staples to the tops underside approximately every 10".

TABLE TOP SUPPORT Each top shall be supported by two 1 7/8" deep, 14-gauge steel aprons. Apron shall contain no holes greater than ½" diameter. Apron shall contain no holes greater than ½" diameter. Aprons shall be capped at the ends with riveted plastic protectors. Each top shall be supported across the width of the top in at least two places.

LEG ASSEMBLIES Tubular leg components shall be 1.05" and 1½" diameter, 14-gauge steel tubing. Legs and stool columns shall be constructed of 1½" diameter, 14-gauge steel tubing and shall be braced horizontally to the stool support column on the opposite side of the table to resist bending. Units with stools braced from the floor are not acceptable. Non-marring glides are glass infused nylon that is captured inside the tube with spring clips to stay in place.

STOOLS Stools shall be injection molded with a minimum of 25 oz. of rubber modified, high impact polystyrene materials measuring 13" in diameter. Stools shall be reinforced to resist failure with a minimum of 12 integrally molded, tapered ribs. Ribs shall extend from the outer parameter of the stool to the mounting hub at the center of the stool. Stools shall be mounted with 5/16" diameter bolts and locking nuts with fender washers. Spring pins are not acceptable.

CASTERS Casters shall be heavy-duty, double ball bearing type with a minimum rated load capacity of 275 lbs. each. Casters should have hard rubber non-marking wheels 4" diameter x 1½" wide.

SAFETY REQUIREMENTS Stool units shall be safety tested and listed by Underwriter's Laboratories, Inc. Stool units must display UL labels with valid UL file number. When stool unit is opened for use, all casters shall lift off the ground automatically to minimize table movement while in use. Casters that protrude past the end of the stool unit when opened for use, are prohibited to prevent tripping hazard. Stool units shall have no moving parts that can pinch, cut or pierce the operator's hand while the table is being folded up and down. There shall be at least a 1" gap between the inner leaves of the table tops to prevent pinched fingers.

WARRANTY MTS units covered by 15-year warranty.

MOBILE SHAPE BENCH, STOOL AND COMBO

GENERAL Folding mobile shape cafeteria table shall offer attached benches, stools, or a combination of both benches and stools. The top surface shall be 29" high while bench and stool surface shall be 17" high when opened for use. Leg assemblies shall be chrome plated or epoxy powder coated. When folded the table shall fit through a 36" wide doorway.

ENTRANCES Each stool position shall have its own entrance clear of obstructions when entering the unit to sit down.

LOCKING - OPENING A gravity lock shall automatically lock the table in the open position. The lock is disengaged manually, capable of operating from both sides of the table. The table design shall feature a midway position lock to secure the unit in a partially folded position for ease of movement during floor cleaning and to prevent finger or hand pinching. The lock rod shall be 7/16" diameter and chrome plated to resist wear.

LOCKING - FOLDING A storage lock shall automatically lock the table in the folded storage position. The lock is disengaged manually, capable of operating from both sides of the table within easy reach. Easy opening and closing via a perfectly balanced torsion bar system. Each unit will include 4 torsion bars. 60" Bench Unit has gas springs.

TABLE AND BENCH TOPS Table and bench tops shall be surfaced with high pressure laminate bonded to a ¾" thick MDF core, sealed underneath with a phenolic backer sheet. Bench shall be surfaced with high pressure laminate bonded to a ¾" thick MDF core, sealed underneath with a phenolic backer sheet. Edge of the tops and benches shall be sealed with ProtectEdge, a polyurethane epoxy resin, chemically bound to the edge of the laminate, core and phenolic backing sheet.

Optional Plywood Core with ProtectEdge: Table and bench tops shall be surfaced with high pressure laminate bonded to a ¾" thick AC grade plywood core, sealed underneath with a phenolic backer sheet. Edge of the tops and benches shall be sealed with a polyurethane epoxy resin, ProtectEdge, chemically bound to the edge of the laminate, core and backing sheet.

Optional Plywood Core with Vinyl T-molding: Table and bench tops shall be surfaced with high pressure laminate bonded to a ¾" thick AC grade plywood core, sealed underneath with a poly resin backer sheet. Edge of the tops and benches shall be banded with vinyl T-molding, secured by staples to the tops underside approximately every 10".

Optional Particleboard Core with Vinyl T-molding: Table and bench tops shall be surfaced with high pressure laminate bonded to a ¾" thick 47 lb. particleboard core, sealed underneath with a poly resin backer sheet. Edge of the tops and benches shall be banded with vinyl T-molding, secured by staples to the tops underside approximately every 10".

TABLE TOP SUPPORT Each top shall be supported by two 1 7/8" deep, 14-gauge steel aprons. Apron shall contain no holes greater than ½" diameter. Aprons shall be capped at the ends with riveted plastic protectors. Each top shall be supported across the width of the top in at least two places.

LEG ASSEMBLIES Tubular leg components shall be 1.05" and 1½" diameter, 14-gauge steel tubing. Legs and bench/stool columns shall be constructed of 1½" diameter, 14-gauge steel tubing and shall be braced horizontally to the stool support column on the opposite side of the table to resist bending. Units with stools braced from the floor are not acceptable. Non-marring glides are glass infused nylon that is captured inside the tube with spring clips to stay in place.

STOOLS Stools shall be injection molded with a minimum of 25 oz. of rubber modified, high impact polystyrene materials measuring 13" in diameter. Stools shall be reinforced to resist failure with a minimum of 12 integrally molded, tapered ribs. Ribs shall extend from the outer parameter of the stool to the mounting hub at the center of the stool. Stools shall be mounted with 5/16" diameter bolts and locking nuts with fender washers. Spring pins are not acceptable.

CASTERS Casters shall be heavy-duty, double ball bearing type with a minimum rated load capacity of 275 lbs. each. Casters should have hard rubber non-marking wheels 4" diameter x 1½" wide.

SAFETY REQUIREMENTS Stool units shall be safety tested and listed by Underwriter's Laboratories, Inc. Stool units must display UL labels with valid UL file number. When stool unit is opened for use, all casters shall lift off the ground automatically to minimize table movement while in use. Casters that protrude past the end of the stool unit when opened for use, are prohibited to prevent tripping hazard. Stool units shall have no moving parts that can pinch, cut or pierce the operator's hand while the table is being folded up and down. There shall be at least a 1" gap between the inner leaves of the table tops to prevent pinched fingers.

WARRANTY MTR units covered by 15-year warranty.

MOBILE TABLE WITHOUT SEATING

GENERAL Folding mobile cafeteria table shall have a top surface consistent with the size/shape specified. The top surface shall be 29" high unless otherwise noted. When folded the table shall fit through a 36" wide doorway.

NPS Product Specifications

ENTRANCES / FRAME Mobile Table units without seating offer open a continuous range of entry points around the table surface perimeter. All other metal frame components should be epoxy powder coated or chrome option.

LOCKING – OPENING A gravity lock shall automatically lock the table into the open storage position. The lock is disengaged manually, capable of operating from both sides of the table. The table design shall feature a midway position lock to secure the unit in a partially folded position for ease of movement during floor cleaning and to prevent finger/hand pinching. The lock rod shall be 7/16" diameter and chrome plated to resist wear.

LOCKING – FOLDING A storage lock shall automatically lock the table in the folded storage position on styles/sizes where applicable. The lock is disengaged manually, capable of operating from both sides of the table within easy reach. Easy opening and closing via a perfectly balanced torsion bar system when applicable. MT48, MT60, MT6072, and MT72 tables are balanced to operate without torsion bars. MTMT8, MT10, and MT12 units shall include 3, 2, or 1 torsion bar(s) determined by table size and core material.

TABLE TOPS Table tops shall be surfaced with high pressure laminate bonded to a ¾" thick MDF core, sealed underneath with a phenolic backer sheet. Edge of the tops shall be sealed with ProtectEdge, a polyurethane epoxy resin, chemically bound to the edge of the laminate, core and phenolic backing sheet.

Optional Plywood core with ProtectEdge: Table tops shall be surfaced with high pressure laminate bonded to a ¾" thick AC grade plywood core, sealed underneath with a phenolic backer sheet. Edge of the tops and benches shall be sealed with a polyurethane epoxy resin, ProtectEdge, chemically bound to the edge of the laminate, core and backing sheet.

Optional Plywood Core with Vinyl T-molding: Table and bench tops shall be surfaced with high pressure laminate bonded to a ¾" thick AC grade plywood core, sealed underneath with a poly resin backer sheet. Edge of the tops and benches shall be banded with vinyl T-molding, secured by staples to the tops underside approximately every 10".

Optional Particleboard Core with Vinyl T-molding: Table and bench tops shall be surfaced with high pressure laminate bonded to a ¾" thick 47 lb. particleboard core, sealed underneath with a poly resin backer sheet. Edge of the tops shall be banded with vinyl T-molding, secured by staples to the tops underside approximately every 10".

TABLE TOP SUPPORT Each top shall be supported by two 1 7/8" deep, 14-gauge steel aprons. Apron shall contain no holes greater than ½" diameter. Apron shall contain no holes greater than ½" diameter. Aprons shall be capped at the ends with riveted plastic protectors as needed.

LEG ASSEMBLIES Leg assemblies shall have vertical tubes supporting the benches and shall be constructed of 1½" diameter, 14-gauge steel tubing. All other tubular components shall be 1.05" diameter, 14-gauge steel tubing, or structural members of equal or greater strength.

CASTERS Casters shall be heavy-duty, double ball bearing type with a minimum rated load capacity of 275 lbs. each. Casters should have hard rubber non-marking wheels 4" diameter x 1¼" wide.

SAFETY REQUIREMENTS MTMT8, MT10, and MT12 Rectangular units shall be safety tested and listed by Underwriter's Laboratories, Inc. Rectangular units must display UL labels with valid UL file number. When unit is opened for use, all casters shall lift off the ground automatically to minimize table movement while in use. Units shall have no moving parts that can pinch, cut or pierce the operator's hand while the table is being folded up and down. There shall be at least a 1" gap between the inner leaves of the table tops to prevent pinched fingers.

WARRANTY MT units covered by 15-year warranty.

MOBILE CONVERTIBLE BENCH UNIT

GENERAL Folding mobile convertible bench unit shall have a top surface measuring 15" wide and a bench surface measuring 12". The top surface shall be 29" high when opened for use. The top and bench length shall be 8' or 7' or 6'. Each unit shall have a bench that can be opened for use and closed for transporting. Each unit shall have a tabletop that can be raised up as a tabletop or lowered as a bench back.

STANDARD: Standard ganging with all units allows joining two tables together securely for cafeteria style seating.

TABLE AND BENCH TOPS: Table and bench tops shall be surfaced with high pressure laminate bonded to a ¾" thick MDF core, sealed underneath with a phenolic backer sheet. Edge of the tops and benches shall be sealed with a polyurethane epoxy resin, ProtectEdge, chemically bound to the edge of the laminate, core and phenolic backing sheet.

Optional Plywood Core with ProtectEdge: Table and bench tops shall be surfaced with high pressure laminate bonded to a ¾" thick AC grade plywood core, sealed underneath with a phenolic backer sheet. Edge of the top and bench shall be sealed with a polyurethane epoxy resin, ProtectEdge, chemically bound to the edge of the laminate, core and backing sheet.

Optional Plywood Core with Vinyl T-molding: Table and bench tops shall be surfaced with high pressure laminate bonded to a ¾" thick AC grade plywood core, sealed underneath with a poly resin backer sheet. Edge of the top and bench shall be banded with vinyl T-molding, secured by staples to the tops underside approximately every 10".

OPTIONAL PARTICLEBOARD CORE WITH VINYL T-MOLDING: Table and bench tops shall be surfaced with high pressure laminated bonded to a ¾" thick 47 lb. particleboard core, sealed underneath with a poly resin backer sheet. Edge of the top and bench shall be banded with vinyl T-molding, secured by staples to the top and bench underside approximately every 10".

TABLE TOP SUPPORT Each top shall be supported by two 1 7/8" deep, 14-gauge steel aprons. Aprons shall contain no holes greater than ½" diameter. Table tops shall be supported with steel gussets at approximately every 30".

LEG ASSEMBLIES Vertical tubes supporting the tabletop and benches shall be constructed of 1½" 14-gauge square tubing. Horizontal tubing for bench supports shall be made of 1 1/8" 14-gauge round tubing. Horizontal tubing shall be fitted to bench with eight 3" x 2" steel plates welded onto 1½" 14-gauge metal tubes. The steel plates shall be connected to underside of bench with five screws. Horizontal leg bottoms shall be constructed of 1½" 14-gauge square tubing and shall be chrome plated. All square and round tubing shall have plastic end closures. Rubber glides include a spring clip inside the square tubing of the leg to insure they stay in place.

GANGING & FOLDING SAFETY A flexible one-piece molded UV resistant glass-filled nylon draw latch shall be mounted to the outside of each apron. Two units facing together shall be quickly locked together at each end of the table for cafeteria-type seating configurations. The latch shall lock against the apron for storage when not in use. An embedded pin in the leg system will prevent finger pinching and wear on the table top and bench surface when in a closed storage position.

CASTERS Casters shall be heavy-duty, double ball bearing type with a minimum load capacity of 150 lbs. each. Casters shall have non-marking wheels 3" diameter x 1" wide. Two of the casters shall be locking to keep unit in place while in use.

SAFETY REQUIREMENTS Units shall be safety tested and listed by Underwriter's Laboratories, Inc. Units must display UL labels with valid UL file number. Unit shall have no moving parts that can pinch, cut or pierce the operators hands while the tabletop or benches is being folded up or down. The exclusive embedded pin design will prevent pinching.

WARRANTY CB units are covered by a 15 year warranty.

EASYFOLD MOBILE FLIPPER TABLE

MTSSF-60R/Q/H/O/V MTSSF-48R/Q/H

GENERAL Folding mobile cafeteria table shall have a top surface consistent with the size/shape specified. The top surface shall be 29" high unless otherwise noted. When folded the table shall fit through a 36" wide doorway.

ENTRANCES/FRAME Mobile Table units without seating offer open a continuous range of entry points around the table surface perimeter. All metal frame components should be epoxy powder coated or chrome leg option.

LOCKING - OPENING A gravity lock shall automatically lock the table into the open storage position. The lock is disengaged manually, capable of operating from two locations on one side of the table. The lock rod shall be 7/16" diameter and chrome plated to resist wear. Tamper resistant lock nuts on all down lock assemblies with self-adjusting pawl catch ensure the down lock engages every time.

LOCKING – FOLDING MTSSF-60R/Q/H/O/V tables are balanced to operate with a gas/oil filled spring. The design of the table remains locked into the folded position without until the user begins to open the table manually.

TABLE TOPS Table tops shall be surfaced with high pressure laminate bonded to a ¾" thick MDF core, sealed underneath with a phenolic backer sheet. Edge of the tops shall be sealed with Protect Edge, a polyurethane epoxy resin, chemically bound to the edge of the laminate, core and phenolic backing sheet. Tamper resistant table top screws provide superior holding power to frame with the ability to be serviced easily in the field.

Optional Plywood core with Protect Edge: Table tops shall be surfaced with high pressure laminate bonded to a ¾" thick AC grade plywood core, sealed underneath with a phenolic backer sheet. Edge of the tops and benches shall be sealed with a polyurethane epoxy resin, Protect Edge, chemically bound to the edge of the laminate, core and backing sheet.

Optional Plywood Core with Vinyl T-molding: Table and bench tops shall be surfaced with high pressure laminate bonded to a ¾" thick AC grade plywood core, sealed underneath with a poly resin backer sheet. Edge of the tops and benches shall be banded with vinyl T-molding, secured by staples to the tops underside approximately every 10".

Optional Particleboard Core with Vinyl T-molding: Table and bench tops shall be surfaced with high pressure laminate bonded to a ¾" thick 47 lb. particleboard core, sealed underneath with a poly resin backer sheet. Edge of the tops shall be banded with vinyl T-molding, secured by staples to the tops underside approximately every 10".

TABLE TOP SUPPORT Each top shall be supported by two 1 7/8" deep, 14-gauge steel apron uni-frame design. Apron shall contain no holes greater than ½" diameter. Apron shall contain no holes greater than ½" diameter. Tamper resistant table top screws provide superior holding power to frame with the ability to be serviced easily in the field.

LEG ASSEMBLIES Leg assemblies shall have vertical tubes (round) supporting the tables and caster lift off tubes (square) shall be constructed of 1½" diameter, 14-gauge steel tubing. All other tubular components shall be 1.05" diameter, 14-gauge steel tubing, or structural members of equal or greater strength. Tamper-proof non-marring nylon steel insert glides and tube closures will not break or fall out.

CASTERS Jarvis Casters shall be heavy-duty 4" diameter x 1¼" wide double ball swivel, non-marring with a minimum rated load capacity of 275 lbs. each. To minimize unnecessary table movement once in place, casters shall lift off the ground as table transitions from folded to open in-use position.

SAFETY REQUIREMENTS When unit is opened for use, all casters shall lift off the ground automatically to minimize table movement while in use. Units shall have no moving parts that can pinch, cut or pierce the operator's hand while the table is being folded up and down.

CERTIFICATIONS Cafeteria Tables have been tested to pass MAS Green® Certification.

WARRANTY Cafeteria Tables are warranted against manufacturer's defects for 15 years.

TGT2448PBTM/TGT2460PBTM/TGT3048PBTM/TGT3060PBTM/ TGT2448MDPE/TGT2460MDPE/TGT3048MDPE/TGT3060MDPE

TOGO MOBILE TABLE

- Available in 4 sizes: 24" x 48", 24" x 60", 30" x 48", 30" x 60"
- Table core options: MDF/ PARTICLEBOARD
- Table Edge options: PROTECT EDGE/ VINYL T-MOLDING
- Frame Color: Powder Coated
- Heavy duty magnet
- 14 gauge steel frame
- Easy nesting and storage
- Laminate color options: Grey Nebula, Montana Walnut, Banister Oak, Wild Cherry, Fusion Maple, Marigold, Hollyberry, Persian Blue

NPS Product Specifications

TGB48PBTM/TGB60PBTM/TGB48MDPE/TGB60MDPE

TOGO MOBILE BENCH

- Available in 2 Sizes: 25" x 48", 25" x 60"
- Table core options: MDF / PARTICLEBOARD
- Table Edge options: PROTECT EDGE/ VINYL T-MOLDING
- Frame Color: Powder Coated
- 14 gauge steel frame
- Easy nesting and storage
- Laminate Surface or Padded option available

CAFÉ

BCC/BCS SERIES / BUSHWICK CAFÉ CHAIR AND STOOL

- 8 layer bent plywood seat with a high end HPL finish
- Legs are made of 7/8 in. 16 gauge chrome tubing.
- Modern handle for easy movement and storage.
- 4 fully welded 12 gauge under-seat support brackets
- Heavy duty bumpers for safe and secure stackability
- Durable non-marring polypropylene glides
- Weight Capacity Exceeds 500 lbs
- Plywood core is made with poplar wood and eucalyptus wood
- Available colors: ■ Natural ■ Espresso

CT SERIES / FIXED HEIGHT CAFÉ TABLE

- 1 1/4" High Pressure Laminate tops with T-Mold available in standard and custom colors
- Available in round, square, rectangle, racetrack, and curved in a variety of sizes
- Legs available in X-base, T-base, or round base
- Legs come with 1/2" thick non-marring polypropylene mushroom leveling glides to prevent floor scratching
- Pole connects to base with 1 heavy-duty bolt with thread locker
- Textured Black Powder Coated Frame
- 16 gauge 3" thick pole
- 8 gauge steel base
- 12 gauge support plate is fully welded to base for extreme stability
- 300 lbs Weight Capacity

PCT / PREMIUM PLUS CAFE TABLES

- High pressure laminate and whiteboard tabletops are easy to clean and will resist scratches.
- Available in both round and square shapes in 24", 30" & 36" size tops.
- Tables adjust from 30" to 42" using a smooth and easy to adjust pneumatic lever.
- Heavy-duty 13 gauge steel column and 1/2 inch steel base.
- 3" Heavy-Duty Polyurethane non-marring locking swivel casters.
- Table top folds and locks into place and can be nested with other tables for safe compact storage.
- ANSI/BIFMA certified meeting all TSCA title VI requirements
- Blowmolded Top: Charcoal Slate
- Available laminate colors: ■ Grey Nebula ■ Montana Walnut ■ Banister Oak ■ Wild Cherry ■ Fusion Maple ■ Marigold ■ Hollyberry ■ Persian Blue

CTT3042 / ADJUSTABLE HEIGHT CAFE TABLE

- Tabletops are made of lightweight charcoal colored HDPE blow molded plastic.
- Tabletop measures 36"x 36"
- Tabletop thickness: 1 3/8"
- Features 12" of pneumatic height adjustment from 30" - 42"
- Tabletops flip and tables nest together for space-saving storage
- Table frame, column and base are made of silver-tone powdercoated steel
- Gauge of steel: 16 gauge
- Tables tested to support up to 700 lbs. and are guaranteed for ten years.
- Furnished with plastic adjustable floor levelers
- MAS certified Green®
- Tables are lightweight weighing only 32 1/2" lbs. and are easy to assemble
- Carton dimensions are 36 1/2" L x 36 1/2" W x 4" D. Carton weight: 37 lbs.
- Ships with UPS or by truck at class 125.

CTS30 / BISTRO HEIGHT CAFE STOOL

- Seats and back are made of lightweight charcoal colored HDPE blow molded plastic.
- Seat height is 30"
- Seat size is 17" x 16"
- Seat thickness is 2 1/8"
- Back size is 18 1/8" W x 9" H x 1 1/8" D
- Overall height is 42"
- Frames are made of silver-tone powdercoated 1-1/8" steel
- Gauge of seat frame: 16 gauge
- Gauge of legs: 18 gauge
- Assembled width & depth: 22 3/4" W x 19 3/4" D
- Furnished with rubber floor friendly glides for floor protection.
- Stools are guaranteed for ten years.
- MAS certified Green®
- Stools are lightweight weighing only 12 1/2" lbs.
- Carton dimensions are 20 1/2" W x 23" D x 42 1/2" H. Carton weight: 17 lbs.
- Ships with UPS or by truck at class 300.
- Max stacking capacity: 3
- 300 lbs Weight Capacity

CLT SERIES/ COLLABORATOR TABLE

- Available with a 1 1/4" HPL, 1 1/4" Butcherblock or Whiteboard Industrial Grade top.
- Available in dining height (30") as well as bar height (42").
- Bar Height tables include crossbeam for extra stability.
- 5 gauge support plates
- Solid 8 gauge Industrial grade frame
- 2 leveling glides on each base
- Powder-Coated Black Santex Frame
- 500 lbs Weight Capacity

MUSIC

82MS / MUSIC STAND

- Durable 22-gauge aluminum surface is 20 1/2" wide and features safe rolled edges to prevent harm to instruments or people.
- Black textured finish resists chips and scratches
- Adjustable desk angle and height from 24 to 46 (from bookrest lip to floor) with the spring-loaded tube.
- Stand Is 18-Gauge, 1" O.D. Steel
- Tension Tilt Surface For Smooth Adjustment And Holds Strong In Any Position
- Powder-Coated In Black To Match Melody Music Chair
- New Rubber Tips Included To Prevent Noise And Floor Scratching
- New Attachment Style Eliminates The Need For Bolt Tightening
- 50mm thread lock base bolt and enhanced lock washer prevent the pole from loosening at the base.

SERIES 8200 / MELODY STACK CHAIR / MELODY STACK CHAIR JR.

8210 DIMENSIONS: 33 1/2"H X 19"W X 21 1/2"D
SEAT (8210): 17 1/2"H X 16 1/2"W X 16 1/2"D
OPTIONAL TABLET ARM WITH PLYWOOD CORE FLIPS UP TO FOLD
BEHIND CHAIR: 13 3/4"W X 17"D X 1/2"H

8210-16 DIMENSIONS: 31 1/2"H X 19"W X 21 1/2"D
SEAT (8210-16): 16"H X 16 1/2"W X 16 1/2"D
OPTIONAL TABLET ARM WITH PLYWOOD CORE FLIPS UP TO
FOLD BEHIND CHAIR: 13 3/4"W X 17"D X 1/2"H

- Features a 7/8" powder coated paint frame with 16-gauge square tubing
- 14-gauge rear seat brace
- Band-pitch style with a seat back angle of 97 degrees
- Durable Polypropylene contoured seat for extra comfort
- Can be stacked 18 high on our DY-82 with 4 stack bumpers to protect finish
- Weighs 12 lbs
- 300 lbs Weight Capacity
- Available Colors: ■ Black

DYMS10 / DOLLY FOR 82MS MUSIC STANDS

DIMENSIONS: OVERALL: 47"H X 27"W X 31"L

- Strong 15-gauge steel frame in chrome for long-lasting performance
- 10 stand capacity

NPS Product Specifications

- Large wheels measure 2" x 8" and small wheels are 3/4"x2"
- Handles are covered in soft rubber for extra comfort
- Plastic covering on holding arm for added protection
- Lightweight design it is easy to move a fully loaded unit up and down stairs
- Ship weight: 29lbs.

DYMS20 / DOLLY FOR 82MS MUSIC STANDS

DIMENSIONS: OVERALL: 27"W X 47"H X 59"L

- Strong 15-gauge steel frame in chrome for long-lasting performance
- Large stationary casters measure 2"x8" and small swivel casters measure 1"x5"
- 20 stand capacity
- Handles are covered in soft rubber for extra comfort
- Plastic covering on holding arm for added protection
- Ship weight: 48lbs.

STAGES & RISERS

PERFORMANCE STAGES AND SEATED RISERS

INCLUDES 36"W AND 48"W STAGES STAGE PIECES, STAGE PIES, & STAGE SETS

- Constructed with 3/4" solid plywood core
- Available with carpet in choice of 4 colors or 1/8" thick tempered hardboard
- 16-gauge, 1-13/16" high formed steel channel frame reinforced with 16-gauge steel angle welded to the inside of the channel
- 14-gauge steel tubing capped at the point of floor contact with high impact plastic glides
- Legs open and close using only one hand
- Stages and risers equipped with drop-in couplings that allow units of same or different heights to be joined together
- All ganging devices are permanently secured to each unit
- Exceeds 200 lbs. per square foot load bearing capacity
- Available in 36" and 48" widths
- Comes in 4 heights; 8", 16", 24" and 32"
- Skirting available for all stages in 2 styles; shirred pleat and box pleat
- Optional Stage Pies for semi-circle arrangements
- 3 step heights available to connect to 16"H Stages and above
- Optional Guardrails recommended for safety. Guardrails are 14-gauge
- 10-year warranty

TFX STAGES / ADJUSTABLE HEIGHT STAGES

- Constructed with 3/4" solid plywood core
- Available with carpet in choice of 4 colors or 1/8" thick tempered hardboard
- 16-gauge, 1-13/16" high formed steel channel frame reinforced with 16-gauge steel angle welded to the inside of the channel
- 14-gauge steel tubing
- Legs open and close using only one hand
- Stages equipped with drop-in couplings that allow units of same or different heights to be joined together
- All ganging devices are permanently secured to each unit
- Exceeds 200 lbs. per square foot load bearing capacity
- Stages measure 48"x48" or 48"x96" and are available in two adjusting sizes - 16"- 24" and 24"- 32"
- Adjustable legs are made of plated 14 gauge steel and are capped with high impact plastic glides
- Stage rolls on two 2" rubber casters for easy mobility
- Legs are equipped with clevis pins to lock adjusting legs in place
- Skirting available in 2 styles; shirred pleat and box pleat
- 3 step heights available to connect to 16"H Stages and above
- Optional Guardrails recommended for safety. Guardrails are 14-gauge
- 10-year warranty

CHORAL RISERS / RS AND RT SERIES

- Constructed with 3/4" solid plywood core
- Available with carpet in choice of 4 colors or 1/8" thick tempered hardboard
- 16-gauge, 1-13/16" high formed steel channel frame reinforced with 16-gauge steel angle welded to the inside of the channel
- 14-gauge steel tubing capped at the point of floor contact with high impact plastic glides
- Legs open and close using only one hand
- Nylon 6 glides + 30% glass fiber (PA6-630)
- Equipped with drop-in couplings that allow units of same or different heights to be joined together

- All ganging devices are permanently secured to each unit
- Exceeds 200 lbs. per square foot load bearing capacity
- Comes in 4 heights; 8", 16", 24" and 32"
- Straight and Tapered units for continuous and semi-circle configurations
- Optional Guardrails recommended for safety
- 10-year warranty

TRANS-PORT RISER

- Available in three 18" wide levels; 8", 16" and 24" high that are permanently joined with hinge mechanisms to enable the unit to open and close in a unified fashion
- Each unit is equipped with wheels for easy transportation when folded and to allow for easy positioning after set up
- Riser levels supported by a 3" deep, double walled, extruded anodized aluminum frame that overlaps the top of each level to protect the carpet edge
- Riser platforms constructed of 3/4" plywood, surfaced with polyolefin carpet
- Optional guardrails constructed of black epoxy powder-coated tubular steel and equipped with clamp-on attachments for easy installation
- Straight or Tapered units available for various configurations
- Now avail: 4th Level Add-On: TPA: 18-1/8"W x 72 1/2"L x 32 1/2"H TPRA: 18"W x 79"L x 32 1/2"H
- Standing Capacity: TP72: 15-18 adults (with 4th level TPA: 20-23) TPR72: 11-14 adults (with 4th level TPRA 16-19)
- 10-year warranty

STAGE ACCESSORY PARTS

STP16/STP24/STP32 / STEPS FOR STAGES

DIMENSIONS: STP16: 36"W X 14"D X 42"H, 42 LBS. STP24: 36"W X 28"D X 48"H, 72 LBS. STP32: 36"W X 42"D X 54"H, 110 LBS.

- Made of high grade plywood edged with vinyl t-molding
- Frame is powdercoated in black
- Steps coated with Polypropylene textured surface
- Color of steps is grey
- Frame is built with 14 gauge steel tubing
- Unit rolls on two wheels

GRR24S/GRR32S/GRR24T/GRR32T / BACK GUARDRAILS FOR RISERS

DIMENSIONS: GRR24S 94"L X 66"H, 51 LBS. GRR32S 94"L X 74"H, 55 LBS. GRR24T 70"L X 66"H, 40 LBS. GRR32T 76"L X 74"H, 43 LBS.

- For use with Straight & Tapered Risers
- Top and bottom horizontal tubes are 1 1/2" O.D.
- Black powdercoated steel
- Middle horizontal tubes are 1" O.D.
- All tubes are 1 4 gauge steel
- Ends of tubes are outfitted with high impact plastic flower end-caps.
- Vertical tubes are 1 1/4" O.D.

GRTPR3 / GRTPR4 / BACK GUARDRAILS FOR TRANS-PORT RISER

DIMENSIONS: GRTPR3 70 1/2"L X 66 1/4"H, 69 LBS. GRTPR4 70 1/2"L X 74 1/4"H, 75 LBS.

- For use with Straight & Tapered Trans-port Risers
- Top and bottom horizontal tubes are 1 1/2" O.D.
- Black powdercoated steel
- Middle horizontal tubes are 1" O.D.
- All tubes are 14 gauge steel
- Ends of tubes are outfitted with high impact plastic flower end-caps.
- Vertical tubes are 1 1/4" O.D.

SGRTP3 / SGRTP4 / SIDE GUARDRAILS FOR TRANS-PORT RISERS

DIMENSIONS: GSGRTP3 59 1/4"L X 63 1/2"H, 10 LBS. SGRTP4 79 1/4"L X 71 5/8"H, 11LBS.

- For use with Straight & Tapered Trans-port Risers
- Vertical and horizontal tubes are 1 1/4" O.D.
- Black powdercoated steel
- Ends of tubes are outfitted with high impact plastic flower end-caps.
- All tubes are 14 gauge steel

NPS Product Specifications

GRS30/GRS36/GRS48 / GUARDRAILS FOR STAGES

DIMENSIONS: GRS30 30"L X 30"H, 12 LBS. GRS36 36"L X 30"H, 13 LBS. GRS48 48"L X 30"H, 15 LBS.

- For use with stages
- Top horizontal tube is 1 ½" O.D.
- Black powdercoated steel
- Middle and bottom horizontal tubes are 1" O.D.
- All tubes are 14 gauge steel
- Ends of tubes are outfitted with high impact plastic flower end-caps.
- Vertical tubes are 1 ¼" O.D.

SGR2L/SGR3L/SGR4L / SIDE GUARD RAILS FOR STANDARD RISERS

DIMENSIONS: SGR2L 37 7/8"L X 30 7/8"H, 8 ¾ LBS. SGR3L 57 1/3"L X 28 5/8"H, 11 LBS. SGR4L 77 ¼"L X 30 7/8"H, 12 LBS.

- For use with standard risers
- Vertical and horizontal tubes are 1 ¼" O.D.
- Black powdercoated steel
- Ends of tubes are outfitted with high impact plastic flower end-caps.
- All tubes are 14 gauge steel

CG28/CG32/CG37/CG44/CG54/CG72/CG81/CG96 / CHAIR GUARDS

DIMENSIONS: CG28 28"L, 3 LBS. CG32 32"L, 3 LBS. CG37 37"L, 3¾ LBS. CG44 44"L, 3¾ LBS. CG54 54"L, 4 LBS. CG72 72"L, 4¾ LBS. CG81 81"L, 5 LBS. CG96 96"L, 5½ LBS.

- For use with stages and stage pies
- Ends of Chair Guards are outfitted with high impact plastic flower end-caps.
- Tube is made of 1" O.D.
- Tube is 14 gauge steel.
- Chair Guards are powdercoated in black.

SDL / STAGE DOLLY

DIMENSIONS CAPACITY: SIX STAGES

- Rolls on four 6" casters
- Can be used for both 36" 48" stages
- Black powdercoated steel
- Built with 14 gauge tubular steel

DIVIDERS

ROBO ROOM DIVIDERS:

Fabric:

- Units are 6' in height
- Available in the following four sizes:
 - 3-Panel (opened length 72")
 - 5-Panel (opened length 118")
 - 7-Panel (opened length 164")
 - 9-Panel (opened length 210")
 - 11-Panel (opened length 256")
- Sound Absorbing PET Panels
- Flame retardant: B1 grade
- Panels are Tackable
- Self-Leveling Casters
- Tech-Lock brakes for End Frame casters
- Full-Length Hinges
- Secure Storage Fastener
- Unique foot-pedal release.
- Position Regulator keeping panels in place
- Heavyweight- non tipping
- Gangable- Join multiple units together to form a long division or substitute room
- Available in the fabric colors: ■ Black ■ Blue ■ Grey

Acrylic:

- Units are 6' in height
- Available in the following four sizes:
 - 3-Panel (opened length 72")
 - 5-Panel (opened length 118")
 - 7-Panel (opened length 164")
 - 9-Panel (opened length 210")
- 3/16-inch clear OPTIX® acrylic

- Self-Leveling Casters
- Tech-Lock brakes for End Frame casters
- Full-Length Hinges
- Secure Storage Fastener
- Unique foot-pedal release.
- Position Regulator keeping panels in place
- Heavyweight- non tipping
- Ganging- Join multiple units together to form a long division or substitute room

LECTERNS

GSL GRAYSTONE LECTERN

DIMENSIONS: READING SURFACE: 22.75"W X 18.25"D
SIDE PULL OUT TRAYS(R&L): 14.25"W X 12"D
FRONT PULL OUT TRAY: 17.5"W X 9.25"D
TOP TWO CABINET SHELVES: 21"W X 14.75"D X 7"H
BOTTOM CABINET SHELF: 21"W X 14.75"D X 12"H
DRAWER: 6.25"W X 15"D X 13.25"H
PRODUCT WEIGHT: 93 LBS.

- Sleek grey plywood provides for a smooth writing surface
- Units roll on four 2" double wheeled hooded casters

GSL-S GRAYSTONE LECTERN WITH SOUND

DIMENSIONS: READING SURFACE: 22.75"W X 18.25"D
SIDE PULL OUT TRAYS(R&L): 14.25"W X 12"D
FRONT PULL OUT TRAY: 17.5"W X 9.25"D
TOP TWO CABINET SHELVES: 21"W X 14.75"D X 7"H
BOTTOM CABINET SHELF: 21"W X 14.75"D X 12"H
PRODUCT WEIGHT: 95 LBS.

- Sleek grey plywood provides for a smooth writing surface
- Units roll on four 2" double wheeled hooded casters
- Built in sound system
- Bluetooth enabled
- Includes a handheld mic with 9' cable and a gooseneck shock mount mic holder
- Amplifier works with OS wireless microphones
- Includes a tie-clip/lapel mic with 10' cable
- Multimedia capabilities include simultaneous usage with two wired and one wireless (optional) microphones

111PLS POWER PLUS LECTERN

COLORS: MAHOGANY, RIBBONWOOD
PRODUCT WEIGHT: 50LBS.
READING SURFACE DIMENSIONS: 20"WX14.35"D
OVERALL DIMENSIONS: 22"WX17"DX46"H

- Power Output: 30 Watts
- Includes One Handheld Mic And One Tie-Clip/Lavaliere Mic
- Flexible Gooseneck Arm
- Input/output Lines For Media Players, Extension Speakers, Recording And Playing Mp3S
- Features A 12.5"Wx4.25"D Storage Shelf
- High Pressure Thermal-Fused Laminate On A MDF Core
- Durable Scratch Resistance Surface

ARISTOCRAT SERIES W/ SOUND

COLORS: MAHOGANY
PRODUCT WEIGHT: 90LBS.
READING SURFACE DIMENSIONS: 23.5"WX17"D
OVERALL DIMENSIONS: 25"WX20"DX46"H

- Includes 50-Watt Multimedia Amplifier
- Two Built In 8"Speakers
- Includes One Handheld Mic And One Tie-Clip/Lavaliere Mic
- Equipped With One Digital Timepiece
- Flexible Gooseneck Arm
- Input/output Lines For Media Players, Extension Speakers, Recording And Playing Mp3S
- High Pressure Thermal-Fused Laminate On A Mdf Core
- Durable Scratch Resistance Surface
- Equipped With Four Roll Casters, Two Locking
- Assembly Required

NPS Product Specifications

800X ORATOR LECTERN

COLORS: MAHOGANY, RIBBONWOOD
PRODUCT WEIGHT: 63LBS.
READING SURFACE DIMENSIONS: 22.5"WX17"D
OVERALL DIMENSIONS: 22"WX17"DX46"H

- Equipped With 40 Watts Multiplayer Amplifier
- Amp has a USB port and Bluetooth capabilities
- Includes One Handheld Mic And One Tie-Clip/Lavalier Mic
- Input/output Lines For Media Players, Extension Speakers, Recording And Playing Mp3S
- Features A 12"X4" Storage Shelf
- Equipped With A Reading Lamp
- Digital Timepiece Included
- High Pressure Thermal-Fused Laminate On A MDF Core
- Durable Scratch Resistance Surface
- Equipped With Four Casters, Two Locking

950/901 COMBO FLOOR SOUND LECTERN

COLORS: MAHOGANY ON WALNUT
PRODUCT WEIGHT: 187LBS.
READING SURFACE DIMENSIONS: 22.5"WX12.6"D
OVERALL DIMENSIONS: 24"WX20.5"DX48"H

- Custom Built-In 75 Watt Multimedia Amplifier
- Four 4" Speakers Mounted In
- For Audiences Up To 7500 People Or 750000 Sq.
- Includes One Handheld Mic And One Tie-Clip/Lavalier Mic
- Input/output Lines For Media Players, Extension Speakers, Recording And Playing MP3
- Three Sizeable Storage Spaces And Two Adjustable Shelves
- Two Locking Doors
- Equipped With Reading Lamp
- Digital Timepiece Included
- Ac Plug And Optional Battery Operation Include

611S FLOOR LECTERN W/ SOUND

COLORS: RIBBONWOOD
PRODUCT WEIGHT: 71LBS.
READING SURFACE DIMENSIONS: 16.25"WX23.6"D
OVERALL DIMENSIONS: 24"WX21"DX46"H

- Equipped With Two Shelves
- High Pressure Thermal-Fused Laminate On A Miff Core
- Durable Scratch Resistant Surface
- Equipped With Four Concealed Casters, Two Locking
- Assembly Required

612S FLOOR LECTERN W/ SCREEN AND SOUND

COLORS: RIBBONWOOD
PRODUCT WEIGHT: 73LBS.
READING SURFACE DIMENSIONS: 16.25"WX23.6"D
OVERALL DIMENSIONS: 24"WX21"DX46"H

- Perfect For Customizing Logos for Institutions and Presentations
- Equipped With a 15" LCD Screen Build Into the Front Of The Unit
- Display Images Uploaded With a SD-Card or Flash DriveIncludes a Remote Control
- High Pressure Thermal-Fused Laminate on A MDF Core
- Durable Scratch Resistant Surface
- Equipped With Four Concealed Casters, Two Locking

22 TABLETOP LECTERN

COLORS: MAHOGANY, MEDIUM OAK, BLACK
PRODUCT WEIGHT: 31LBS.
OVERALL DIMENSIONS: 23.75"WX19.875"DX13.75"H

- Functions On Its Own or In Conjunction With 112 Floor Lectern Base
- Features A Paper/Book Stop
- High Pressure Thermal-Fused Laminate On A particleboard Core
- Durable Scratch Resistant Surface

112 LECTERN BASE

112 LECTERN BASE

COLORS: MAHOGANY, MEDIUM OAK, BLACK
PRODUCT WEIGHT: 50LBS.
OVERALL DIMENSIONS: 21.125"WX17.5"DX33.75"H

- Use with 22 Tabletop Lectern to make a Full Floor Lectern
- Use As An A/V Cart For Presentation Equipment
- Includes Storage Shelf
- Equipped With Four Roll Casters, Two Locking
- Durable Scratch Resistant Surface
- High Pressure Thermal-Fused Laminate On A particleboard Core

222 FULL FLOOR LECTERN

COLORS: MAHOGANY, MEDIUM OAK
PRODUCT WEIGHT: 55LBS.
OVERALL DIMENSIONS: 23"WX16"DX46.5"H

- Features Full Size Reading Surface
- Spacious Shelf for Storage
- Built In Paper/Book Stop
- High Pressure Thermal-Fused Laminate on a Particleboard Core
- Durable ScrDurable Scratch Resistant Surface
- Floor Glides Provided
- Assembly Required
- Optional Caster Kit Available

401S ACRYLIC LECTERN

COLORS: CLEAR
PRODUCT WEIGHT: 55LBS.
OVERALL DIMENSIONS: 24"WX15"DX46"H

- Light Weight and Made From 1/2" And 3/8" Thick Acrylic Plexiglas
- Features a 24"X16" Reading Surface with Book Stop
- Features Convenient 14"X8" Shelf
- Contemporary Style Lectern
- Perfect for Worship and Modern Business Setting

70 LECTERN

COLORS: CHERRY, MEDIUM OAK, MAHOGANY
PRODUCT WEIGHT: 14LBS.
OVERALL DIMENSIONS: 20"WX18.25"DX30-44"H

- Practical Speaker Stand Lectern
- Features 16"X20" Reading Surface
- Adjustable Height From 30"-44"
- Features Protective T-Mold Edging
- Includes Paper/Book Stop
- Features A 16-Gauge Steel Frame

NPS Product Specifications

600 ARISTOCRAT NON-SOUND LECTERN

COLORS: MAHOGANY, MEDIUM OAK, WILD CHERRY
PRODUCT WEIGHT: 92LBS.
OVERALL DIMENSIONS: 25"WX20"DX46"H

- Features 2 Built-In Shelves
- Features 1 Slide-Out Shelf
- Slide Out Shelf Wt. Capacity: 35 Lbs.
- High Pressure Thermal-Fused Laminate On A Mdf Core
- Durable Scratch Resistant Surface
- Attractive T-Mold Edging
- Equipped With Four Roll Casters, Two Locking
- Assembly Required

611 VISION LECTERN

COLORS: RIBBONWOOD
PRODUCT WEIGHT: 68LBS.
READING SURFACE DIMENSIONS: 16.25"WX23.6"D
OVERALL DIMENSIONS: 24"WX21"DX46"H

- Equipped with Two Shelves
- High Pressure Thermal-Fused Laminate on a MDF Core
- Durable Scratch Resistant Surface
- Equipped With Four Concealed Casters, Two Locking
- Assembly Required

612 VISION LECTERN W/ SCREEN

COLORS: RIBBONWOOD
PRODUCT WEIGHT: 70LBS.
READING SURFACE DIMENSIONS: 16.25"WX23.6"D
OVERALL DIMENSIONS: 24"WX21"DX46"H

- Perfect for Customizing Logos for Institutions and Presentations
- Equipped with a 15" LCD Screen Built into the Front of the Unit
- Display Images Uploaded with a SD-Card or Flash Drive
- Includes a Remote Control
- High Pressure Thermal-Fused Laminate on a MDF Core
- Durable Scratch Resistant Surface
- Equipped With Four Concealed Casters, Two Locking

ZED LECTERN

COLOR: BLACK
PRODUCT WEIGHT: 47.6 LBS.
PRODUCT DIMENSIONS: 19.5"W X 19.5"D X 46.5"H

- Equipped With 40 Watts Multiplayer Amplifier
- Built four 4" 40W speakers
- Includes One gooseneck Mic and One Tie-Clip/Lavaliere Mic
- Input/output Lines for Media Players, Extension Speakers, USB, Bluetooth, Recording & Playing Mp3S
- Equipped with a Halogen Lamp
- Digital Timepiece Included
- High Pressure Thermal-Fused Laminate on A MDF Core
- Durable Scratch Resistance Surface
- Equipped with Four Casters

CHARGING CARTS

DCC DUET CHARGING CART

DIMENSIONS: OVERALL: 281/8"W X 22"D X 38 3/4"
SURFACE: 22 3/4"W X 21 1/8"D
SHELF: 22 3/4"W X 15 1/2"D

- 2 UL approved power strips with 32 outlet
- Power components are UL and cUL certified
- Adjustable height shelves can be adjusted in 2 1/3" increments
- Fits laptops and tablets with all types of screens up to 15.6" when configured to hold 32 devices
- Maintenance area with four storage shelves for device adaptors
- 18-gauge heavy-duty steel parts
- 4 heavy-duty 4" casters, 2 locking

- 2 point locking system on front and back doors
- One 12ft. power cord to plug into wall
- Hook to wrap the power cord on the side of the cart
- Removable well-ventilated dividers
- Dividers can be positioned at any width in 1 1/8" increments
- Built in wire channels on each divider
- Two-tone modern design
- Dura-flex working surface on top of cart

PRESENTATION CARTS

WIZARD PRESENTATION CART

COLORS: WILD CHERRY, BLACK
PRODUCT WEIGHT: 95LBS.
OVERALL DIMENSIONS: 21"WX18"DX40"H

- Constructed Of 18-Gauge Steel With Square Tube Corner Support
- Equipped With A Console—Including Both VGA/HDMI Pass-Through Plate
- One Lockable Storage Cabinet
- Features One Sliding Shelf
- Outfitted With A Flip Up Side Shelf On Desk Surface For Additional Space
- A Large Secured Cabinet With Adjustable Shelf
- Equipped With Four 4" Roll Casters
- Mounted In A 25-Foot Cord With A 6-Outlet Power Strip

MMC PRESENTATION CART

COLORS: WILD CHERRY, BLACK
PRODUCT WEIGHT: 93LBS.
OVERALL DIMENSIONS: 25"WX19"DX38"H

- Features A Front Slide-Out Shelf
- Large Work Surface With Dual Flip-Up Shelves
- One Lockable Storage Cabinet With Adjustable Height Shelf
- One Lockable Draw
- Constructed From High Pressure Thermofused Laminate On Board Core
- Equipped With 3" Casters, Two Locking

PRC200 PRESENTATION CART

COLORS: IVORY WOODGRAIN/BLACK, BLACK
PRODUCT WEIGHT: 36LBS.
OVERALL DIMENSIONS: 18"WX30"DX40.5"H

- Features 4 Shelves For Audio-Visual Equipment
- Adjustable Shelf From 19" To 39.5" For Sitting Or Standing Position
- Equipped With Wire Management Grommets
- Mounted Six Outlet Power Strip
- Furnished In Black Steel Frame With Ivory Wood Grain Shelves
- Equipped With Four 3" Caster, Two Locking

PRC250 PRESENTATION CART

COLORS: IVORY WOODGRAIN/BLACK, BLACK
PRODUCT WEIGHT: 84LBS.
OVERALL DIMENSIONS: 18"WX30"DX40.5"H

- Features 4 Shelves For Audio-Visual Equipment
- Adjustable Shelf From 19" To 39.5" For Sitting Or Standing Position
- Features a lockable cabinet with 3 adjustable/removable shelves Equipped With Wire Management Grommets
- Mounted Six Outlet Power Strip
- Furnished In Black Steel Frame With Ivory Wood Grain Shelves
- Equipped With Four 3" Caster, Two Locking

PRC400 PRESENTATION CART

COLORS: IVORY WOODGRAIN/BLACK, BLACK
PRODUCT WEIGHT: 100.5LBS.
OVERALL DIMENSIONS: 21"WX33"DX40"H

- Features An Extra Large Work Surface And Optional Board
- Outfitted With A Storage Compartment To Safeguard Av Equipment
- 18-Gauge, Black Steel Frame With An Ivory Wood Grain Finish
- Locking Cabinet With An Adjustable Middle Shelf
- Wire Management And Grommets Included
- Equipped With Four 4" Casters, Two Locking

NPS Product Specifications

PRC450 PRESENTATION CART

COLORS: IVORY WOODGRAIN/BLACK, BLACK
PRODUCT WEIGHT: 117.5LBS.
OVERALL DIMENSIONS: 18"W X 30"D X 40.5"H

- Features An Extra Large Work Surface And Optional Board
- Outfitted With A Storage Compartment To Safeguard Av Equipment
- 18-Gauge, Black Steel Frame With An Ivory Wood Grain Finish
- Locking Cabinet With An Adjustable Middle Shelf
- Wire Management And Grommets Included
- A Six-Outlet Power Strip With 20 Ft Cord, And A Cpu Holder Included
- Equipped With Four 4" Casters, Two Locking

BASICS BY NPS

PT3020 / PERSONAL TABLE

- 1.67" thick tabletop.
- NPS Speckled Grey tabletop.
- 20" x 30" tabletop
- Tabletop has a plastic clip to hold the legs in place.
- Powder coated textured grey frames and legs
- Table weight is: 10 lbs
- Table glides are strong and not removable by hand.
- Hex bolt connecting the cross tubes is installed with a nylon insert lock nut and cannot be easily removed.
- Cross brace and tubes are welded nicely.
- Table can be adjusted to 6 different heights:
 - 13-2/3"
 - 18-1/3"
 - 21-2/3"
 - 24-1/4"
 - 26-1/4"
 - 27-7/8"

CL 850 SERIES / COMMERCIALLINE STACK CHAIR

DIMENSIONS: OVERALL: 20"W X 19 1/2"D X 31 3/4"H
SEAT: 17 1/4"W X 17"D X 17"H · BACK: 17 1/4"W X 13 1/2"H

- Polypropylene seat and back
- 18 gauge, 1/2" steel tubing
- Black powdercoated frame
- Ganging glides
- Can stack up to 30 high with our DY-CL85 Dolly
- Chair weight - 8.2 lbs.
- Carton of 4 weight 38.8 lbs. · Carton of 1 weight 13.2 lbs.
- Carton of 4 Dimensions- 23" x 21" x 37" · Carton of 1 Dimensions 22" x 21" x 33"
- Ships from TN
- Freight Class 150
- 250 lbs. weight capacity
- Available Colors: ■ Navy ■ Black

CL 900 SERIES / COMMERCIALLINE ALL-STEEL FOLDING CHAIR

DIMENSIONS: OVERALL: 29 1/4"H X 18"W X 19 1/2"D
FOLDED: 37 3/4"H X 18 1/8"W X 2"D
SEAT: 17 1/4"H X 16"W X 16" D / BACK: 7"H X 17 7/8"W

- Front leg tube: 7/8"x19 gauge
- Rear leg tube: 7/8"x 20 gauge
- Cross bar: 15mm x 21 gauge
- Seat steel plate: 0.8mm
- Back steel plate: 0.6mm
- Chair weight - 8.5 lbs
- Gross weight with box - 36.5 lbs
- 250 lbs. weight capacity
- Available Colors: ■ Beige ■ Grey ■ Black

CL 950 SERIES / COMMERCIALLINE VINYL PADDED FOLDING CHAIR

DIMENSIONS: OVERALL: 29 1/4"H X 18 1/2"W X 19 1/2"D
FOLDED: 37 3/4"H X 18 1/8"W X 2 1/2"D

SEAT: 17 3/4"H X 15 1/2"W X 15 1/2" D / BACK: 7"H X 18"W

- Front leg tube: 7/8"x19 gauge
- Rear leg tube: 7/8"x 20 gauge
- Cross bar: 15mm x 21 gauge
- Seat steel plate: 0.7mm
- Back steel plate: 0.6mm
- Seat fibreboard: 3mm
- Seat/back vinyl: 0.24mm
- Chair weight - 9.75 lbs
- Gross weight with box - 36.5 lbs
- 250 lbs. weight capacity
- Available Colors: ■ Beige/Beige ■ Grey/Grey ■ Black/Black

CL 970 SERIES / COMMERCIALLINE FABRIC PADDED FOLDING CHAIR

DIMENSIONS: OVERALL: 29 1/4"H X 18 1/2"W X 19 1/2"D
FOLDED: 37 3/4"H X 18 1/8"W X 2 1/2"D

SEAT: 17 3/4"H X 15 1/2"W X 15 1/2" D / BACK: 7"H X 18"W

- Front leg tube: 7/8"x19 gauge
- Rear leg tube: 7/8"x 20 gauge
- Cross bar: 15mm x 21 gauge
- Seat steel plate: 0.7mm
- Back steel plate: 0.6mm
- Seat fibreboard: 3mm
- Seat/back vinyl: 0.24mm
- Chair weight - 9.75 lbs
- Gross weight with box - 36.5 lbs
- 250 lbs. weight capacity
- Available Colors: ■ Star Trail Black Fabric / Black Frame, ■ Star Trail Brown Fabric / Beige Frame, ■ Star Trail Blue / Navy Blue Frame

DY-CL85 / DOLLY FOR CL-850 SERIES CHAIRS

DIMENSIONS: OVERALL: 21 1/4"W X 31 1/2"L X 17-1/3"H

- Stacks 30 850-CL chairs.
- Product weight 52 lbs.
- Carton dimensions 22" x 32 1/4" x 18"
- Carton weight 57 lbs.
- Hard Rubber Locking Casters 3" x 1 1/4"

Protecting the environment is one of the most important factors affecting the future of the planet. Most people are now aware of the necessity of preserving and protecting nature in order to ensure our well-being and that of our children. Pollution, especially that related to the over-consumption of raw materials, has reached alarming levels due to our current lifestyle. That is why at National Public Seating® we are constantly striving to minimize the consequences of our activities.

At National Public Seating®, the quality of our products and the protection of the environment go hand in hand. As a consumer of raw material, we are committed to the use of pre and post consumer waste (recycled material), while preserving the high quality standards of our products.



ENVIRONMENTAL STATEMENT

EXAMPLES OF THIS INCLUDE:

- **STEEL** - All of the steel for our products contain 30-40% of post-consumer waste (recycled).
- **CORRUGATED CONTAINERS** - Are made of recycled fiber. 100% total recycled content and 90% post consumer content minimum.
- **PLASTIC** - Our plastic products contain up to 35% of pre-consumer waste.
- **WOOD** - 100% of wood used for our products comes from non-boreal forests.
- **POWDER COATING VS. LIQUID FINISHES** - Our products are powder coated and are highly protective to our environment. While liquid finishes contain solvents which have pollutants known as volatile organic compounds (VOCs), powder coating contains no solvents and releases negligible amounts, if any, of VOCs into the atmosphere. In addition, most powder coating overspray that does not adhere to the part is retrieved and reused, virtually eliminating the waste commonly found in liquid finishing processes.
- **ENERGY** - During November 2008, National Public Seating®, completed a retrofit of all its lighting (over 800 fixtures), to eco-friendly units, saving 135,586 kWh annually. This reduction in energy consumption has an environmental impact equivalent to removing 20 cars from the road, 84 tons of greenhouse gas (CO2) and saving 198 barrels of oil annually!
- **AIR EMISSIONS** - Our Folding Chairs are manufactured within ANSI BIFMA X7.1 2007 VOC Air Emission guidelines; Criteria #1 - TVOC, Formaldehyde, All Aldehydes & 4-Phenylcyclohexene.
- **MAS CERTIFIED GREEN** - The entire NPS® Product Line is now MAS Certified Green™, a nationally recognized registered trademark delineating low VOC emitting products in the marketplace so that purchasers and specifiers of those products know that they can earn credits in sustainability programs like LEED, BIFMA's Level, and California CHP program.
- **SOLAR ENERGY** - As the industry leader in institutional-grade furniture, including portable folding furniture for lunch rooms, training rooms, etc., & furniture for worship halls, science labs, music programs, performing arts, cafeterias & others, NPS® continues to trailblaze in setting the standard for environmental stewardship. In addition to minimizing its eco footprint in the areas of raw material sourcing, energy consumption & air emissions, NPS® is proud to announce a major solar panel installation on the roof of its 200,000 square foot factory facility in its corporate headquarters in Clifton, NJ, completed Summer 2011. Via the installation of a 240KW solar PV system on its roof, we will offset most of the local utility's need to burn oil and gas for electrical production in the public grid and therefore reduce greenhouse gas emissions into the atmosphere. Since we will be generating 80% of the electricity that we use with this system, we have cut our carbon footprint significantly.



WARRANTY INFORMATION

National Public Seating® offers the original user a warranty against all manufacturing defects in material and workmanship from date of purchase for ten years*. If defective, NPS will, at its option, repair or replace the defective product. This warranty does not apply to damage resulting from misuse, abuse or neglect. Excessive swaying back and forth on any banquet stack chair will entirely void the warranty. Authorization for return and / or repairs is required by contacting your dealer. This warranty gives you specific rights, and you may also have other rights which vary by state.

Orders are accepted under the express agreement that under no circumstances will seller be liable for any incidental or consequential damages, or for any other loss,

damage or expense of any kind, including loss of profits, arising in connection with the order or with the use or inability to use seller's products furnished under the order. Seller's maximum liability shall not exceed and buyer's remedy is limited to either (i) repair or replacement of the defective part or product, or at seller's option (ii) return of the product and refund of the purchase price. Such remedy shall be the buyer's entire and exclusive remedy.

*Fifteen years for Mobile Cafeteria Tables,

*One year for Basics By NPS and Butcherblock



ADDRESS 149 Entin Road | Clifton, New Jersey 07014
TEL 800.261.4112 | **FAX** 973.594.9339
www.nationalpublicseating.com





SOLD THRU:

**National
Public
Seating**



149 Entin Road | Clifton, NJ 07014
Tel 800.261.4112 | Fax 973.594.9339
www.nationalpublicseating.com

